



U20CE851/ REPAIR AND REHABILITATION OF
STRUCTURES
STUDY MATERIAL



Prepared by
Dr.R.K.Manikandan
Assistant Professor
Department of Civil Engineering
Dhanalakshmi Srinivasan Engineering College(A),
Perambalur – 621212.

TOPIC 1 : INTRODUCTION

Syllabus: Introduction-Deterioration of Structures-Distress in Structures-Causes and Prevention. Mechanism of damage-Types of Damage

1.1 Definitions

Defects: These are the flaws that are introduced through poor design, poor workmanship before a structure begins its design life or through inadequate operation and maintenance during its service life

Repair: Process of reconstruction and renewal of the existing buildings, either in whole or in part

Renovation: Process of substantial repair or alteration that extends a building's useful life

Remodeling: Essentially same as renovation – applied to residential structures.

Rehabilitation : An upgrade required to meet the present needs – being sensitive to building features and a sympathetic matching of the original construction or the process of repairing or modifying a structure to a desired useful condition.

Restoration: The process of re-establishing the materials, form and appearance of a structure.

Renovation: Process of substantial repair or alteration that extends a building's useful life

Remodeling: Essentially same as renovation – applied to residential structures.

Rehabilitation: An upgrade required to meet the present needs – being sensitive to building features and a sympathetic matching of the original construction.

Strengthening: The process of increasing the load-resistance capacity of a structure or portion.

Retrofitting: The process of strengthening of structure along with the structural system, if required so as to comply all relevant codal provisions in force during that period.

Demolition: The process of pulling down of the structure not deemed to be fit for service.

Need for Repair and Rehabilitation of Structures:

The extent of deterioration to concrete structures globally is occurring at an alarming rate. It is now been confirmed that even if the structural design abides by all the specific building code requirements like the concrete quality, cover etc., there is still an acceptable high risk of deterioration of concrete and corrosion of reinforcement. Steel corrosion is found to be most

severe cause of deterioration of reinforced concrete that can create cracks, spalls the concrete cover, reduce the effective c/s area of the reinforcement and lead to collapse.

The following facts clearly reveal the current status of the existing infrastructure degradation

- In USA about 40% of the highway bridges, about 3,00,000 have been rated as structurally deficient or functionally obsolete or both need about US \$100 billion as estimated expenditure to improve the service life and performance level.
- The situation in India is not better. The reliable figures for estimated expenditure are not available, but it is substantially very high.

The list of possible causes of distress and deterioration in concrete is a long one. The success of any repair program depends upon the correct detection of this distress and deterioration, and cause that lead to deterioration. A rationale approach to any repair and rehabilitation work is to consider the source of the problem and the symptoms together.

The repaired and cured structure has to extend its life for a desirable period. The repair of the repaired structure must be avoided.

Difference between defects, distress and deterioration

Defects: The defects are the flaws those creeps into structure because of design mistakes or poor workmanship during manufacturing, fabrication and construction, before it begins its service life, or by inappropriate operation and maintenance during its service life. The flaw that has a potential to lead to a failure, becomes a defect.

Distress: It is a collective term for the physical manifestation of problems such as cracks, spalls, pop-outs, staining, decay or corrosion. Distress can be thought of as the symptoms indicating that the defects are present.

Deterioration : It is the gradual loss of the desired material properties due to different degradation factors. Deterioration unlike defects, may not surface at the beginning of the service life of a structure , but is rather time-dependent . However , some forms of deterioration may develop early in the service life of structure and others manifest later.

Road Map to Repair of Structures:

The objective of any repair/rehabilitation or strengthening works is to enhance the performance of the structure, extend the service life or increase the load carrying capacity. A rational approach to any repair and rehabilitation work is to consider the source of the cause of the deterioration and symptoms together because treating only the symptoms without adequate understanding of the cause of the problems leads to defects camouflaged beneath the finishes. In any circumstances, the repair of repairs has to be clearly avoided. This can be achieved only if the repair work is carried as per the following steps:

- Condition Evaluation
- Determination of the cause of the deterioration
- Selection of repair methods and materials
- Preparation of drawings and specifications
- Bid and negotiation process
- Execution Process
- Appropriate quality control measures
- Maintenance after completion of the repair works

Problems to be Addressed

- Aging of structures-Expected life and performance
- Deterioration of concrete-causes and effects

- Durability considerations
- Distress diagnostics and performance monitoring-Non-Destructive test methods.
- Damage assessment and evaluation models
- Structural condition assessment
- Analysis and Design of repairs-suitable repair techniques
- Materials for protection, repair and rehabilitation
- Repair Techniques-Shotcreting, guniting etc
- Refurbishment and Strengthening techniques
- Seismic retrofitting
- Bridge rehabilitation

Durability and Permeability Aspects of Concrete

The survey shows that an increase in the strength of cement or concrete has most of the time being accompanied by the corresponding increase in pre-mature deterioration problems. The pre-mature deterioration has been observed even when the concrete construction has been carried out following the best of the practice in terms of its constitution, placement, curing. The other factors that contribute to pre-mature deterioration is the use of cements with higher amount of C3S, increasing the fineness of cement and high w/c ratio, all with common end purpose to gain very high and early strength of concrete.

A durable concrete as per IS 456:2000 is one that performs satisfactorily in the working environment during its anticipated exposure condition during its service life.

Mechanism of Deterioration

Most of the degradation processes encountered by concrete structures such as corrosion, alkali-aggregate reaction, sulfate attack and many other types of physical and chemical deterioration, require water, dissolved chemicals and presence of oxygen.

The two main factors, water tightness and durability of concrete have a major bearing in the resistance of the RCC structures to physical and chemical deterioration. The concrete used in RCC is considered to be substantially water tight and gives enduring performance till the time the capillary pores and micro-cracks ingrained inside the concrete joins with cracks developed due to environmental attack. *The inter facial transition zone* which is the region between the coarse aggregate particles and the bulk hydrated cement paste plays a major role in degradation.

When the concrete mixture is consolidated after placement, along with the entrapped air, a part of the mixing water is also released. The released water travels to the surface of concrete owing to its low density. However, all the bleeding water is not able to find its way to the surface. Due to wall effect of coarse aggregate particles, water films get formed around the particles. This accounts for higher w/c ratio in the vicinity of the aggregate surfaces causing a heterogeneous distribution of water in the system. The dissolution of calcium sulphate and calcium aluminate

compounds during hydration process produces calcium sulphate, hydroxyl, and aluminate ions that combine to form ettringite and calcium hydroxides (Ca(OH)₂) in the adjacent region of aggregate as in the bulk paste.

Owing to higher w/c ratio these crystalline products continue to grow to relatively large crystals in the vicinity of the aggregate. The process of the formation of more porous framework also continues in tandem owing to the evaporation of more water. The interfacial transition zone being porous and weak is susceptible to cracking when subjected to tensile stresses induced by differential movements arising due to the structural loading as well as due to weathering effects, such as exposure to cycles of heating and cooling, wetting and drying leads to the formation of the micro-cracks. Thus concrete has micro-cracks in the interfacial transition zone, even before the structure is loaded.

Micro-cracking in the interfacial transition zone not only influence the mechanical properties, but also the permeability and durability of the concrete structures subjected to severe environmental exposure. The process of chemical and physical deterioration of concrete with time or reduction in durability is generally dependent on the presence and transport of the deleterious substances through concrete. Thus permeability of concrete has greater effect on durability of concrete. The rate of fluid transport in concrete is much larger by percolation through an interconnected network of micro-cracks, macro-cracks, voids and inherent capillary porosity.

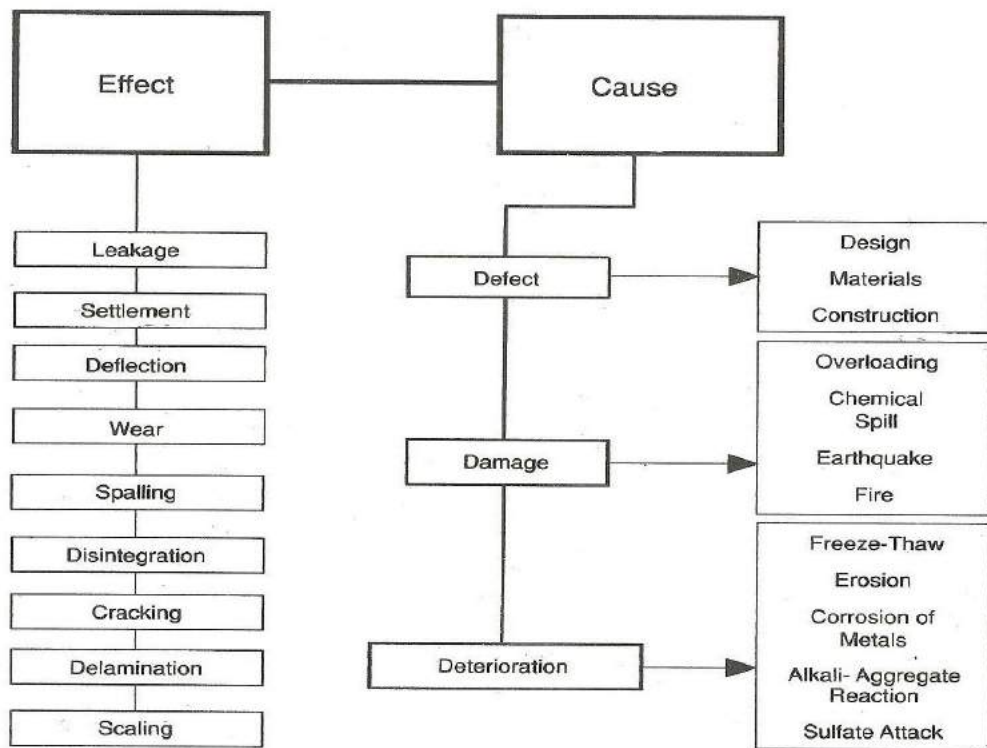

Distress: Distress can be thought of as the symptoms indicating that the defects are present

Types of Distress

Blow holes- sometimes also bug-holes, are individual rounded or irregular cavities that are formed against the formwork and become visible on stripping of the formwork.

Cold joints- These are created when new concrete is poured against the concrete that has just hardened.

Honey Combing- It refers to voids caused by the mortar not filling the spaces between the coarse aggregate particles.

Crazing- It is the network of fine random cracks that are formed due to the shrinkage of the layer relative to the base concrete. It does not pose any structural or Serviceability problem.

Pop-outs- Rough conical depressions in the concrete surface caused by the expansion of the deleterious aggregate particles near the surface or expansion due to freezing are called pop-outs.

Disintegration - two terms generally used to mark this they are Scaling - Localized flaking or peeling away of the near surface portion of the hardened concrete due to freeze thaw, Dusting - White powdery formation on the surface of hardened concrete that receives excessive traffic.

Cracking- Cracking in concrete is inherent. Type of structure and nature of cracking is the major concern. Cracks in the concrete does not always mean that the structure is unusable.

- **Structural Cracks** - Structural cracks are those that may occur due to deficient designs , overloading , abnormal vibrations , use of inferior quality materials , foundation placed on uncompacted /loose soils , adoption of improper construction practices, poor workmanship, etc.



- **Non-Structural Cracks** - These cracks occur due to the internally induced stresses in building material or due to the temperature induced movement of the materials. These cracks mar the appearance of the structure and at time may give a feeling of instability.

Settlement Cracks

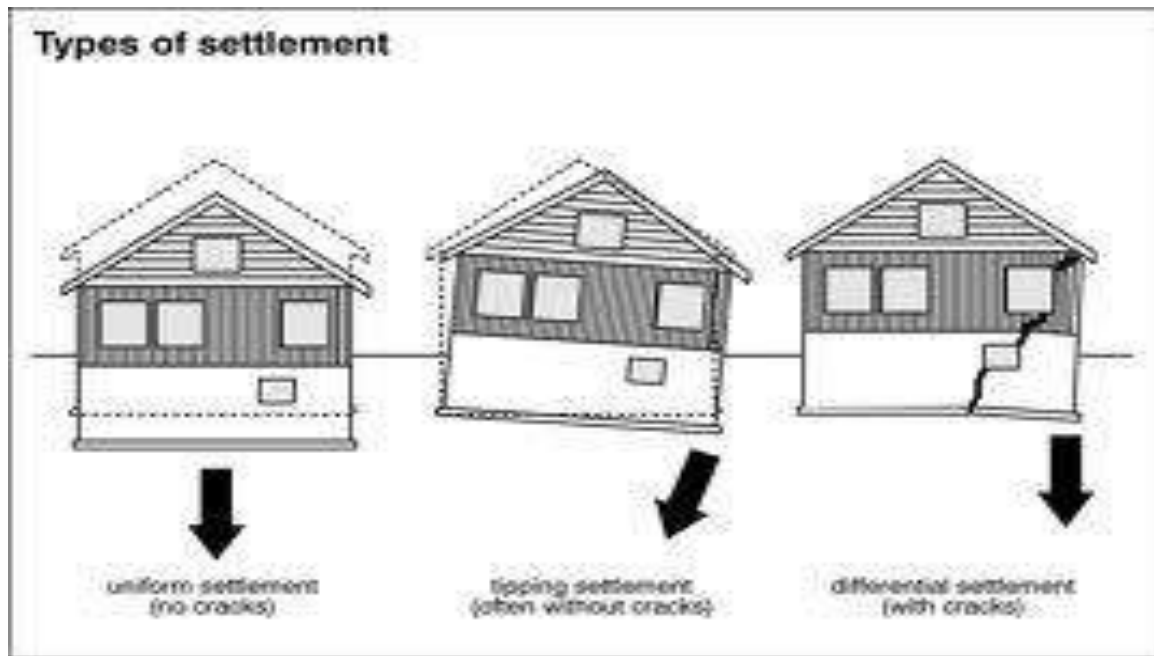

Spalling- It is development of the fragments usually in the shape of the flakes, due to corrosion of steel or freeze thaw effects.



Stain- It is white powdery surface which may be caused by alkali-aggregate reactions. The stain may sometimes be colored due to corrosion of reinforcement.

Erosion- It could be due to abrasion, erosion which is marked by smooth, well-worn abraded surface of concrete, while in cavitation- erosion concrete appears to be very rough and pitted.

Corrosion- Rusting of steel in concrete, this results in cracking or spalling.

Deflection-It is the bending or sagging of the reinforced concrete structural elements like beams, slabs, columns, etc., which can be due to overloading, corrosion, or by creep in concrete.

Scaling of Concrete

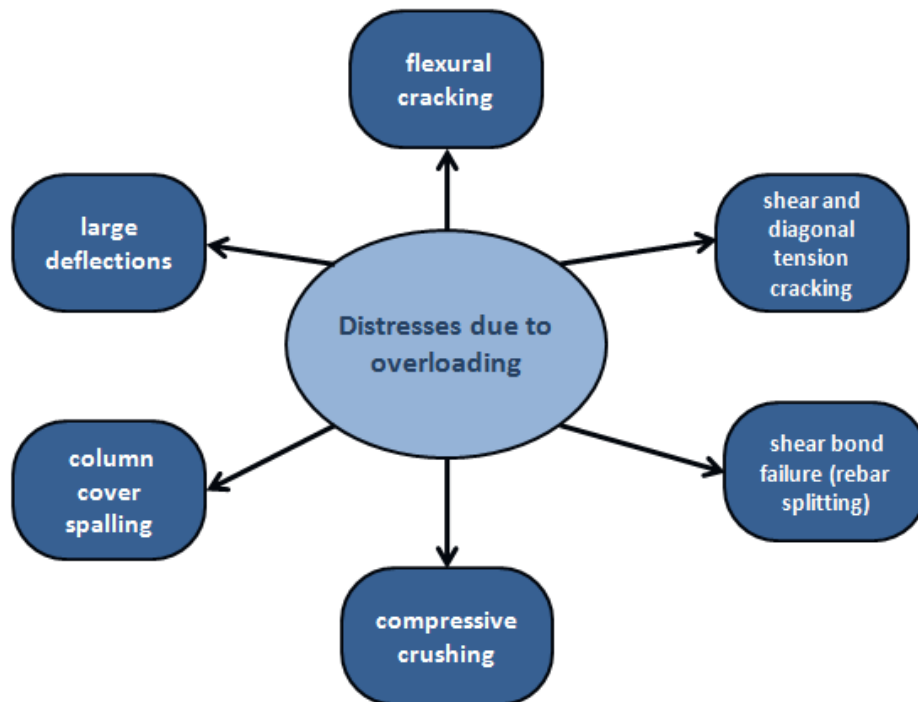

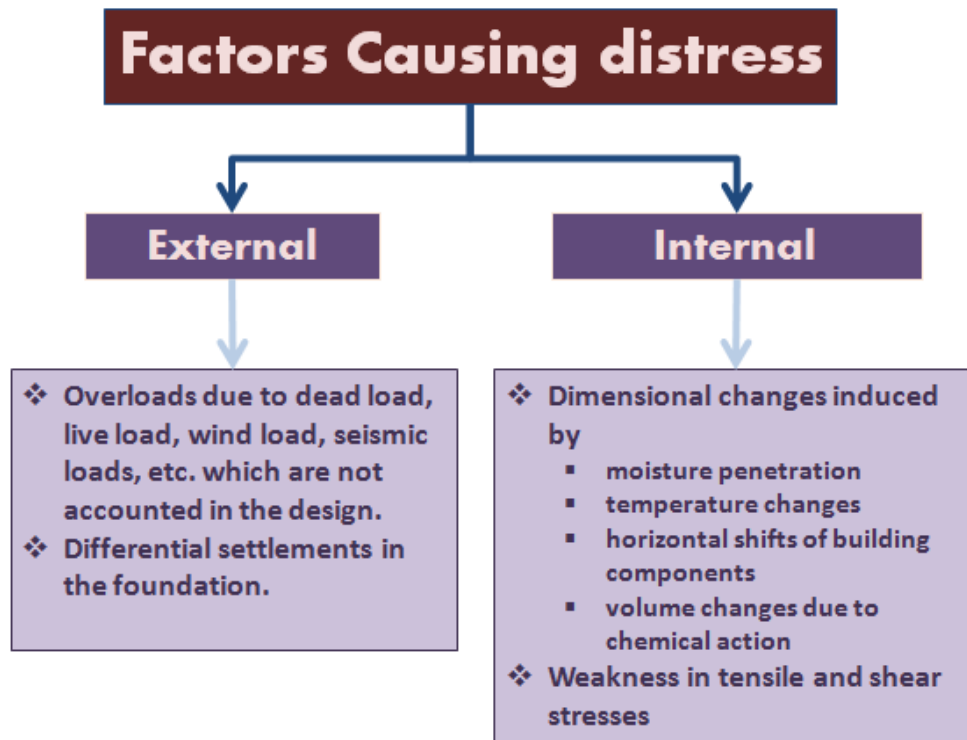

Possible Causes of Damage

- *Pre-Construction stage:*
 - *Poor Design*
 - *Poor Design Detailing*
 - *Poor Deflection Estimations*
 - *Faulty Design of Rigid Joints in Precast Elements*
 - *Faulty Design Estimations at changes in section*

Preventive Measures: Through careful design by experienced design engineers

- **Construction stage**
 - **Local settlement of Subgrade**

Mechanism: Pouring fresh concrete some-times may cause subgrade below it to compress or settle. Uneven stresses thus created cause cracks in the concrete.

Preventive Measures

Pour concrete on compacted subgrade to prevent cracking. If the subgrade is not compacted, the soil, and concrete above it, will settle and cause the slab to crack. Most rental companies have equipment available to properly compact the subgrade, and it is well worth the investment.



- **Swelling of formwork**

Mechanism: Formwork absorbs moisture from concrete or the atmosphere, which results in swelling of form. Crushing of wale in the formwork also causes movements of forms. These result in cracks in the concrete while setting.

Preventive Measures

- Coating of the form work with moisture resistant material.
- Using unyielding lateral ties with good end anchorage

- **Internal settlement of cracks**

Mechanism : Differential settlement between the surface and the interior volume of the concrete suspension causes surface cracks .Concrete on the surface sets faster than the interior suspension.

Preventive Measures

- Surface cracks can be cured and closed by delayed finishing.
- Curing of concrete must start immediately after casting to delay setting of the surface concrete.
- Good compaction will also help prevent this defect.



- **Setting shrinkage**

Mechanism: While setting the concrete shrinks giving rise to surface cracks resembling the scales of the alligator.

Preventive Measures

- Good and timely curing will help avoid this type of damage.

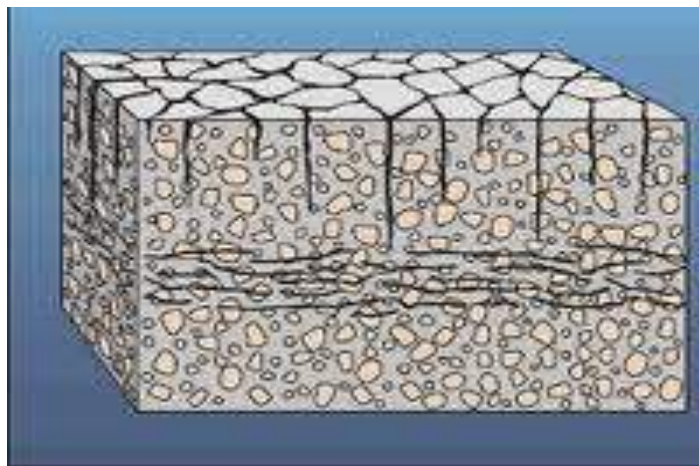

- **Premature removal of shores**

Mechanism: Premature removal of shores from freshly poured concrete causes re-distribution of stresses on form work, causing movements and cracking of concrete.

Preventive Measures

- Shores must be removed only after the concrete has gained sufficient strength.

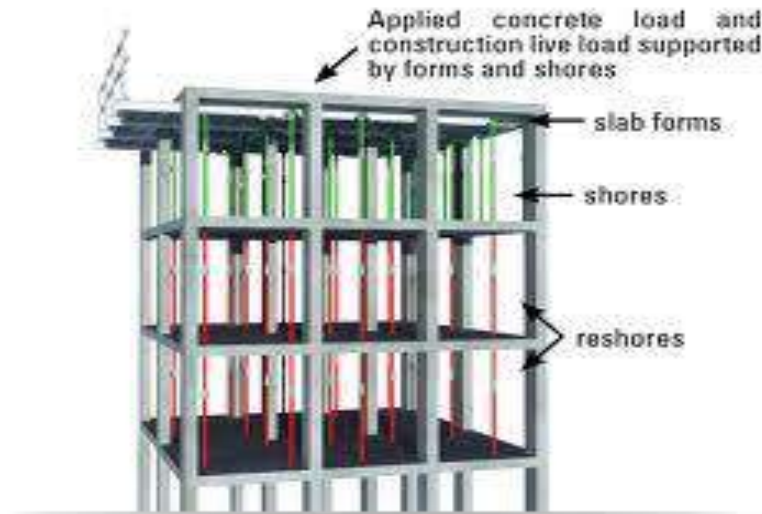

- **Vibrations**

Mechanism: Vibrations due to indiscreet walking over concrete and dumping construction materials, etc., can also lead to cracking

Preventive Measures

- Workers have to be trained in avoiding such carelessness
- **Adding Excess water to Concrete mix:** Water that is added to increase slump decreases durability. Excess water added during finishing causes scaling, crazing and dusting of concrete.
- **Improper curing:** Curing is the most abused aspect of concrete construction. Improper curing causes cracking and surface disintegration. It may also lead to structural cracking. Curing of concrete, if not started soon after its placement, results into setting of the surface concrete that leads to differential settlement.
- **Improper timing of finishing of concrete:** Finishing the surface too soon, i.e., toweling when the bleed water is still there leads to formation of cold joints.
- **Inadequate number of joints:** Inadequate number of contraction joints or fails to make expansion joints wide enough to accommodate the temperature expansion results in severe damage.
- **Improper grading of slab surfaces:** Drains in the slabs requiring draining for runoff must be provided at low and not at high points. Improper location of drains or slope-pitch may result into standing water that causes leakages through cracks and joints.

- **Post-Construction stage**
 - *Temperature Stresses*
 - *Corrosion of steel*
 - *Aggressive action of chemicals*
 - *Weathering action*
 - *Overloading*
 - *Moisture effects*
 - *Natural disasters*
 - *Fire*

- **Temperature Stresses**

Causes: Cracks in concrete can be produced due to temperature stresses due to :

- i. *Difference in temperature inside and outside the building*
- ii. *Variation in the internal temperature due to heat of hydration*

Mechanism: The temperature difference within concrete structure results in differential volume change. When the tensile strain due to differential volume change exceeds the tensile strain capacity of concrete, it cracks. The heat of hydration of cement raises the temperature of concrete, so that the concrete is usually slightly warmer than its surroundings when it hardens resulting into tensile stress and eventually it cracks in different layers.

Preventive measures:

- The finishing of the surface should be such that it reflects solar radiation and not absorbs it.
- Good concrete mix with low heat of hydration
- Allowing for movements by using properly designed contraction joints
- Correct detailing

- **Corrosion of Reinforcement**

Causes : Corrosion of reinforcement bars can be due to: Entry of moisture through cracks, availability of oxygen and moisture at rebar level, carbonation and entry of acidic gaseous pollutants that reduce the pH of concrete, ingress of chloride ions, relative humidity & electrochemical action

Mechanism of Corrosion: The corrosion process that takes place in concrete is electrochemical in nature very similar to a battery. The mechanism of corrosion involves four basic elements

Anode: Site where metal atoms lose electrons i.e., where corrosion is initiated.

Cathode: Site where electrons flow to and combine with other metallic and non-metallic ion.

Electrolyte: A medium capable of conducting electric current by ionic current flow.

Metallic path: Connection between the anode and cathode that completes the circuit.

At, anode the oxidation process releases Fe^{++} ions to concrete pore solution which flows to cathode to combine with hydroxyl ions to form Ferrous hydroxide, $\text{Fe}(\text{OH})_2$. In highly alkaline solution and in absence of chloride ions, the anodic dissolution reaction of iron is balanced by the cathodic reaction. Fe^{2+} ions combine with OH^- ions to produce the stable passive film.

At Anode $\text{Fe} \rightarrow \text{Fe}^{++} + 2\text{e}^-$

At Cathode $\text{O}_2 + 2\text{H}_2\text{O} + 4\text{e}^- \rightarrow 4\text{OH}^-$

Preventive measures:

- Seal the crack before it reaches the reinforcement bar
- Protect against corrosive chemical action by
 - i. Keeping structures clean
 - ii. Painting
 - iii. Prevent from absorbing moisture
 - iv. Provide bituminous or zinc coatings.
 - v. Encase using fibre wrapping systems
- *Proper finishing*

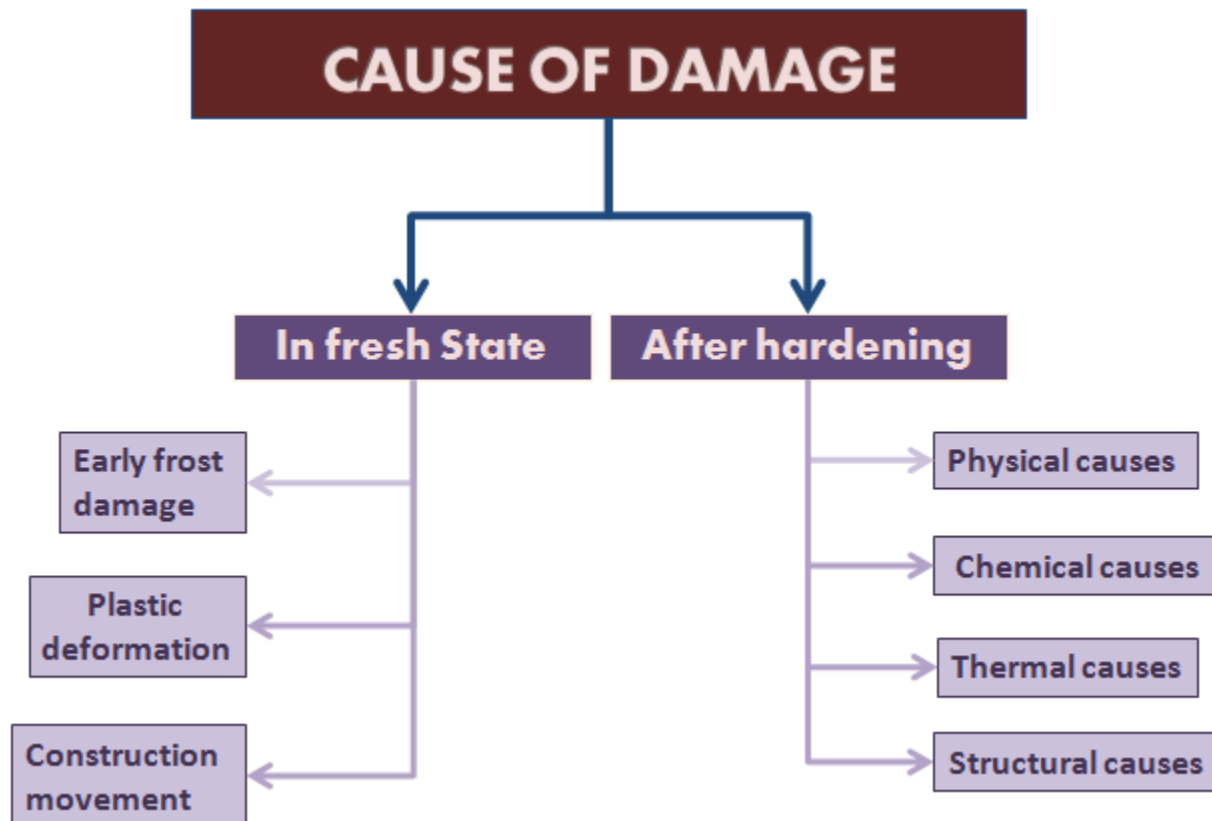

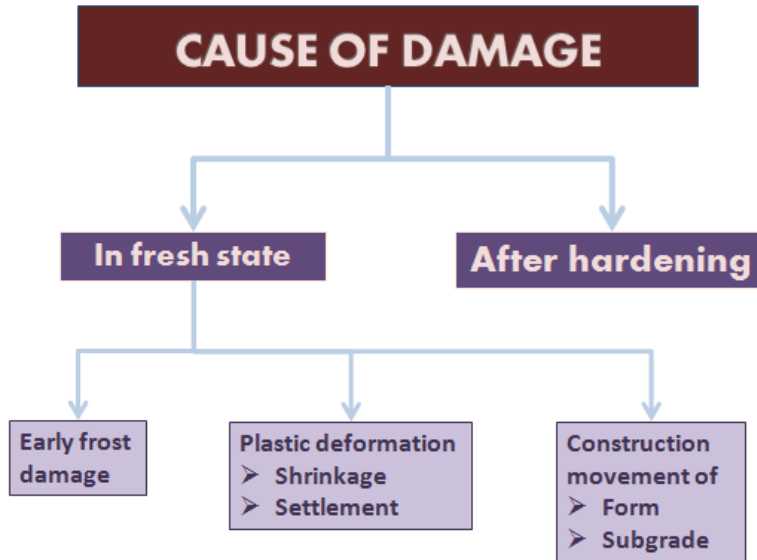

Mechanism of Damage:

Early Frost Damage: When fresh concrete is exposed to extremely low temperatures, the free water in the concrete is cooled below its freezing point and transforms into ice, leading to a decrease in the compressive strength of concrete. When freezing takes place after an adequate curing time, the decrease in compressive strength does not occur.

Early thermal contraction: Fresh concrete undergoes temperature rise due to cement hydration. When concrete is cooling to the surrounding ambient temperature in a few days, the concrete has very little tensile strength.

Weak tensile strength + thermally contracting concrete = tension cracks

Concrete Placed with High Temperature Rise

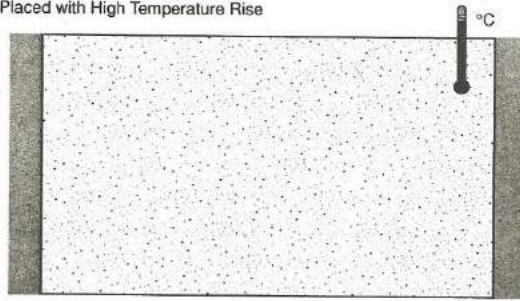

When concrete cools, the member contracts. If restraint occurs, tension develops, forming cracks.

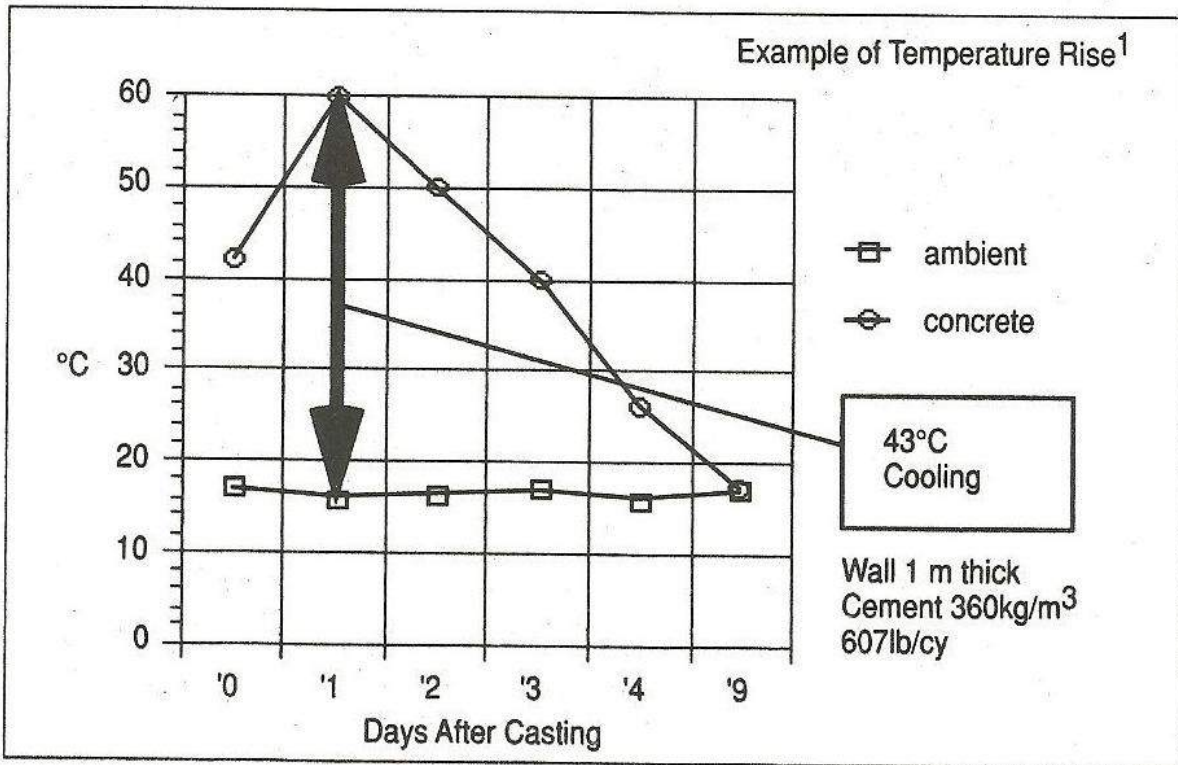
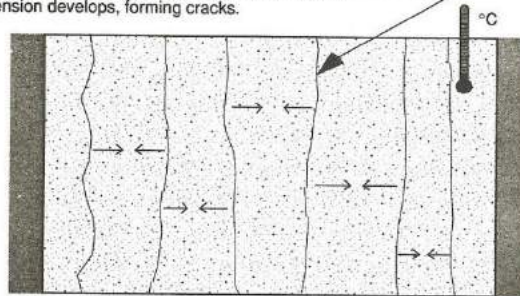

Factors effecting early temperature rise in fresh Concrete:

Initial temperature of materials: Warm materials lead to warm concrete. Aggregate temperature is most critical.

Ambient temperature: Higher ambient temperature leads to higher peaks

Dimensions: Large sections generate more heat.

Curing: Water curing dissipates the build-up of heat. Avoid thermal shock.

Early removal of form work reduces peak temperature.

Type of form work: Wood form produces higher temperatures than steel forms.

Cement Content: More cement in the mix means more heat.

Cement Type: Type III cement produces more heat than most other cements

Admixtures: Fly ash reduces the amount of heat build-up

Plastic Deformation

Shrinkage Cracks:

Plastic shrinkage cracks appear in the surface of fresh concrete soon after it is placed. These cracks appear mostly on horizontal surfaces, and are usually parallel to each other 1-3 feet apart, shallow and not reaching the perimeter of the slab.



Mechanism of shrinkage Cracks:

- Rapid loss of water from the surface of concrete before it has set causes these cracks.
- It is critical when rate of evaporation of surface moisture exceeds the rate at which rising bleed water can replace it.
- Water receding below the concrete surface forms menisci between fine particles of cement and aggregate causing a tensile force to develop in the surface layer.

- If the concrete surface has started to set and has developed sufficient tensile strength to resist these tensile forces, cracks do not form.
- If the surface dries very rapidly before concrete starts to set then cracks develop as the plastic concrete begins to stiffen.

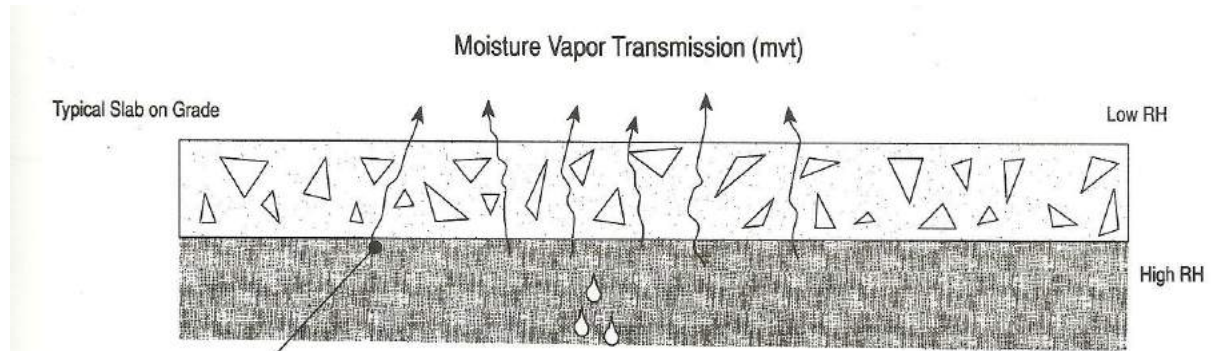

Remedial Measures:

- Dampen the sub-grade and forms when conditions for high evaporation state exist.
- Prevent excessive surface moisture evaporation by providing fog sprays and erecting wind breaks.
- Cover concrete with wet burlap or poly-ethylene sheets between finishing operations.
- Use cooler concrete in hot weather and avoid excessively high concrete temperatures in cold weather.
- Cure properly as soon as finishing has been completed.



Settlement (subsidence)

Mechanism:

- Plastic settlement is caused due to bleeding, which refers to the migration of water to the top of concrete and the movement of solid particles to the bottom of fresh concrete.

- The expulsion of water during bleeding results in the reduction of the volume of fresh concrete. This induces a downward movement of wet concrete.
- If such movement is hindered by the presence of obstacles like steel reinforcement, cracks will be formed.
- Plastic-settlement cracks appear in fresh concrete directly over embedded objects such as reinforcing bars or post-tensioning tendons. They occur because the concrete settles and the embedded objects do not.
- In some cases the whole reinforcing grid appears as cracks on the floor surface.
- Plastic-settlement cracks are most likely where reinforcing bars or post-tensioning tendons are large in diameter and close to the surface.

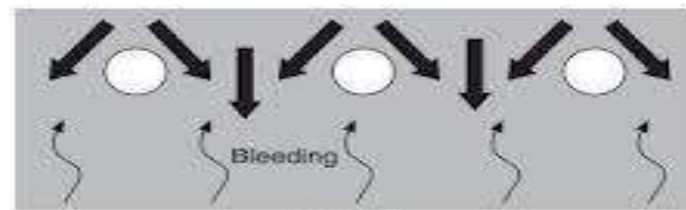

(a) Initiation

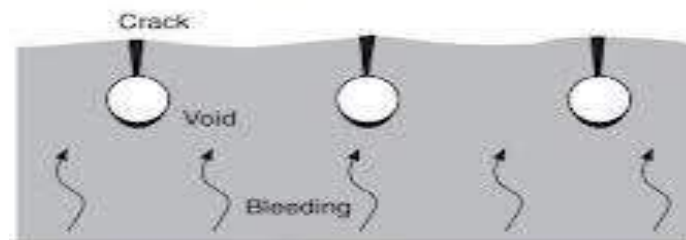

(b) After a few hours

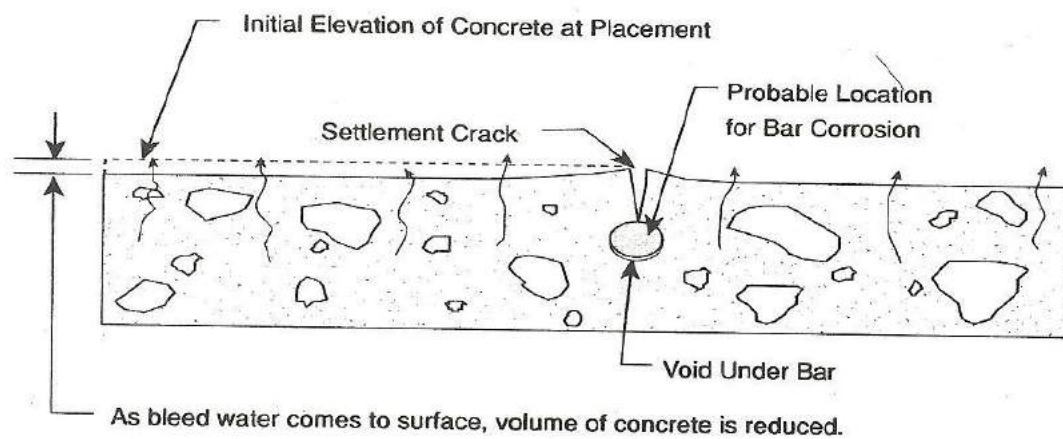

Causes of Plastic Deformation:

Poor construction practices

- Low sand content and high water content

- Large reinforcement bars
- Poor thermal insulation
- Restraining settlement due to irregular shape
- Excessive, uneven absorbency
- Low humidity
- Insufficient time between top-out of columns and placement of slab and beam
- Insufficient vibration
- Movement of formwork

Probability of cracking – A function of

(1) Cover

(2) Slump

(3) Bar size

Probability of Subsidence Cracking (%)									
Cover	2" Slump			3" Slump			4" slump		
	# 4	# 5	# 6	# 4	# 5	# 6	# 4	# 5	# 6
3/4 "	80.4	87.8	92.5	91.9	98.7	100	100	100	100
1"	60	71	78.1	73	83.4	89.9	85.2	94.7	100
1.5 "	18.6	34.5	45.6	31.1	47.7	58.9	44.2	61.1	72
2"	0	1.8	14.1	4.9	12.7	26.3	5.1	24.7	39
# 4 bar = 12.7 mm dia; # 5 bar = 15.875 mm dia; # 6 bar = 19.05 mm dia (Imperial sizes)									
NCHRP 297, Table 4, p.11 (Taken from: P.H. Emmons - p68)									

Remedial Measures

- Use the largest possible coarse aggregate.
- Ensure the coarse aggregate is evenly graded.
- Use less water in the concrete mix (but beware the effect on workability and finishability).

- Leave a generous surcharge when striking off.
- Place deep sections in two or more lifts. This is worth considering when a slab is being cast monolithically with thick joists or beams.

Construction Movement: Form movement

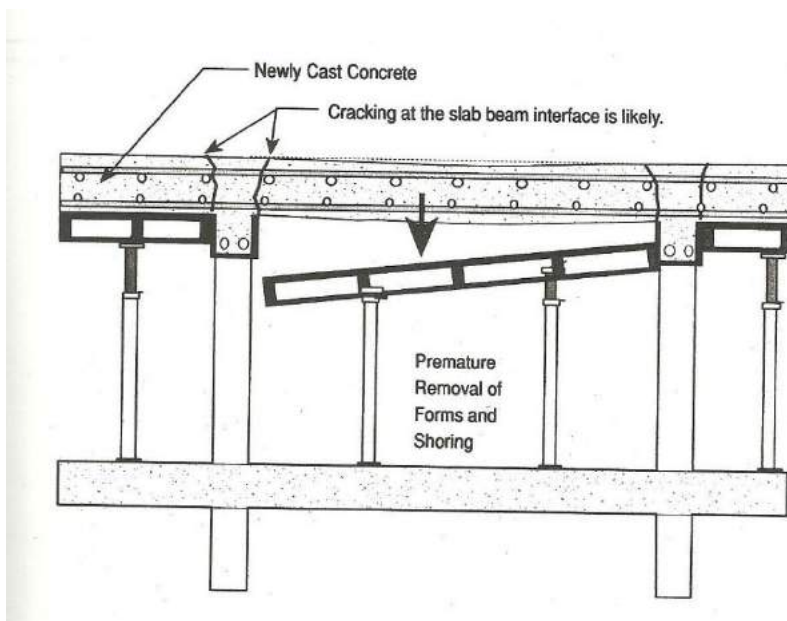
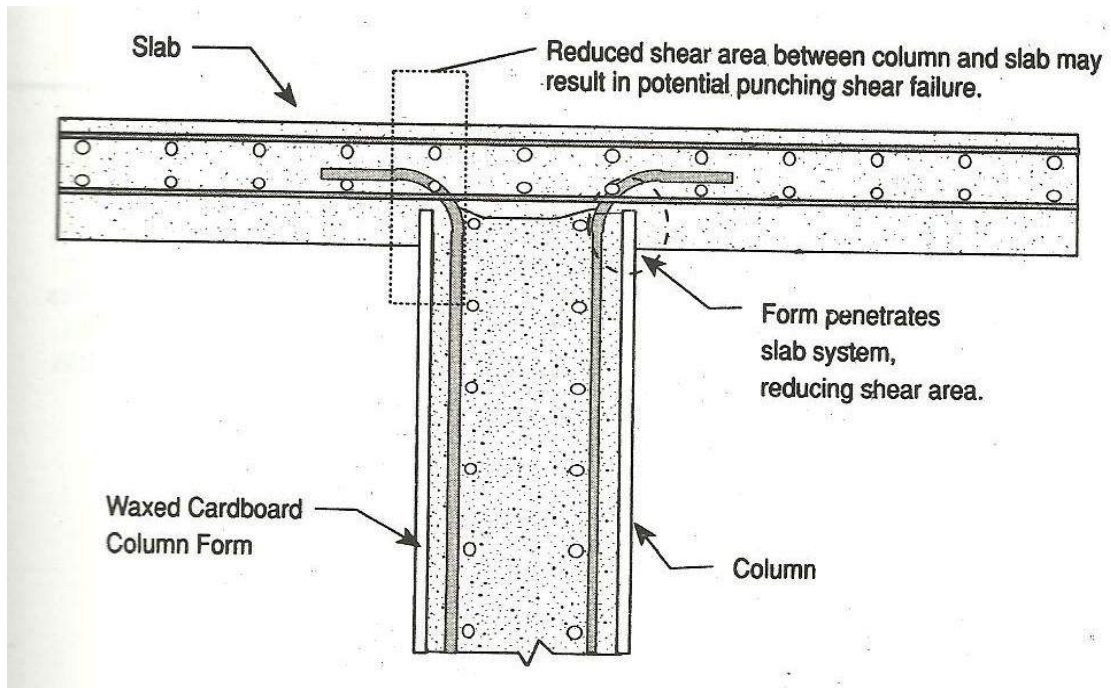

Removal of forms (including shoring) before the concrete has reached its proper strength may result in compression and tension stresses, causing cracking, deflection, and possible collapse.

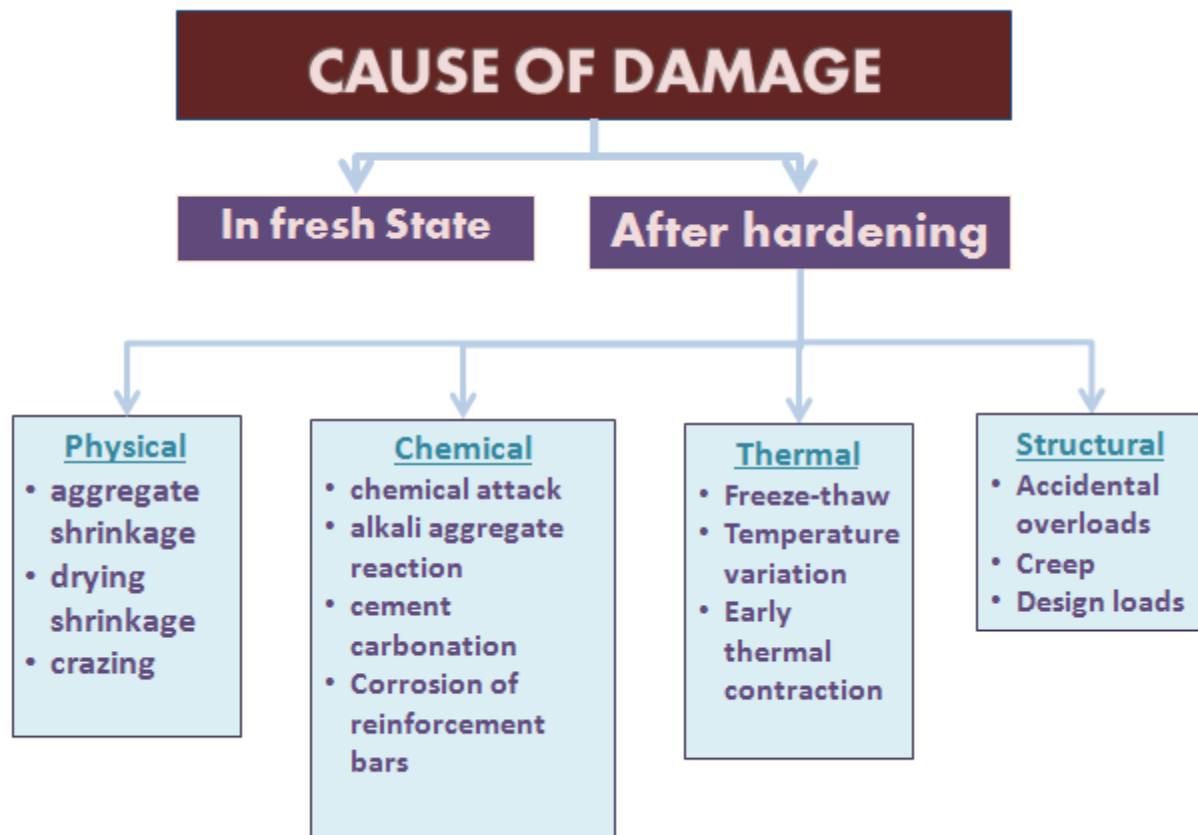

Physical Cause

Aggregate Shrinkage

Mechanism

- Some rocks exhibit the property of absorbing water with attendant change in dimension.
- The shrinkage that occurs as the aggregate dries up is called aggregate drying shrinkage.
- Change in volume of aggregate induces cavities and leads to shrinkage, weakening of compressive strength.

Remedial Measure

- Choose aggregate which do not have these problems

Drying Shrinkage

Mechanism : On exposure to the atmosphere, concrete loses some of its original water through evaporation and shrinks. Normal weight concrete shrinks from 400 to 800 micro-strain. One micro-strain is equal to 1×10^{-6} in./in.

- If unrestrained, results in shortening of the member without a build-up of shrinkage stress. If the member is restrained from moving, stress build-up may exceed the tensile strength of the concrete. this over stressing results in dry shrinkage cracking

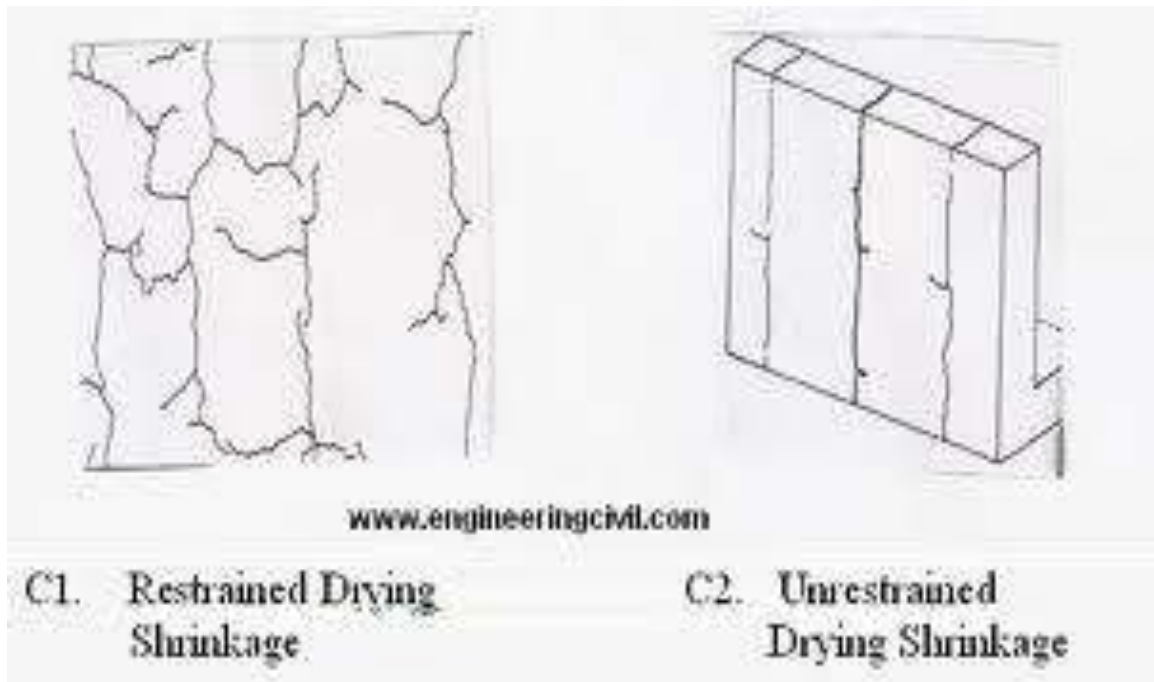
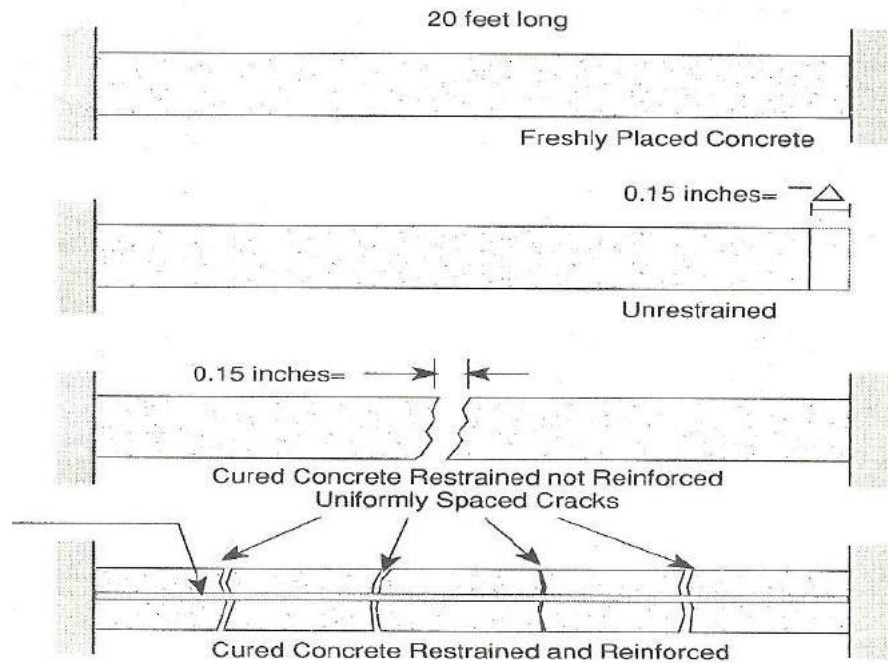

Factors Affecting Drying Shrinkage

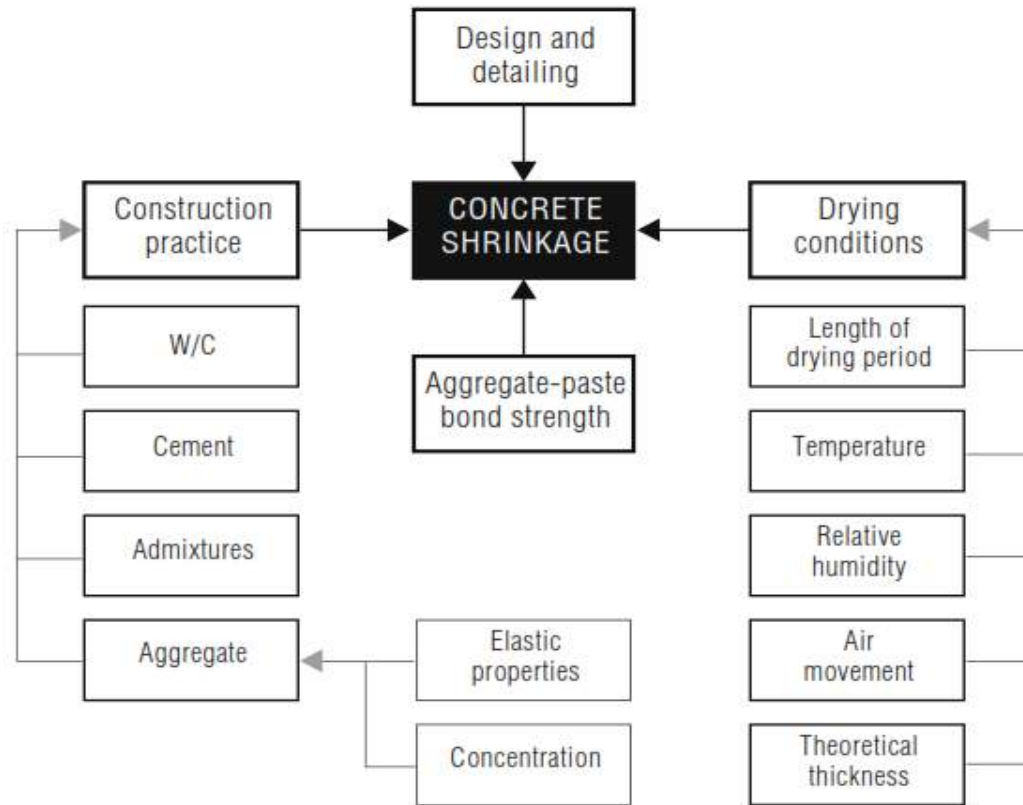

Remedial Measures

Some of the measures that can be taken to reduce the drying shrinkage of concrete include:

- Use the minimum water content (consistent with placing and finishing requirements).
- Use highest possible volume fraction of good quality aggregate and maximum possible aggregate size.
- Use Shrinkage limited Cement (Type SL) where available.
- Do not use admixtures known to increase drying shrinkage, eg those containing calcium chloride.
- Ensure concrete is properly placed, compacted and cured.
- Ensure proper placement of reinforcing steel to distribute shrinkage stresses and control crack widths.

Crazing : Crazing is the development of a network of fine random cracks or fissures on the surface of concrete or mortar caused by shrinkage of the surface layer. These cracks are rarely more than 1/8 inch deep and are more noticeable on steel-troweled surfaces.

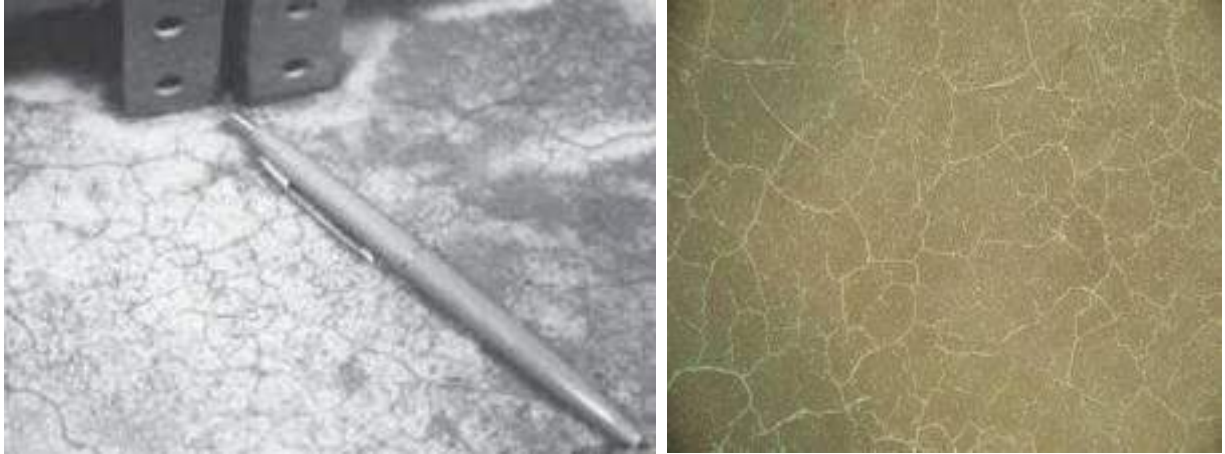

Mechanism:

The irregular hexagonal areas enclosed by the cracks are typically no more than 1 ½ inches across and may be as small as ½ or 3/9 inch in unusual instances. Generally, craze cracks develop at an early age and are apparent the day after placement or at least by the end of the first week. Often they are not readily visible until the surface has been wetted and it is beginning to dry out.

Crazing cracks are sometimes referred to as shallow map or pattern cracking. They do not affect the structural integrity of concrete and rarely do they affect durability or wear resistance. However, crazed surfaces can be unsightly.

Why do Concrete Surfaces Craze?

- Poor or inadequate curing. Intermittent wet curing and drying or even the delayed application of curing will permit rapid drying of the surface and provoke crazing.
- Too wet a mix, excessive floating, the use of any procedures which will depress the coarse aggregate and produce an excessive concentration of cement past and fines at the surface.
- Finishing while there is bleed water on the surface or the use of a steel trowel at a time when the smooth surface of the trowel brings up too much water and cement fines.

Preventive measures

- To prevent crazing start curing the concrete as soon as possible. The surface should be kept wet by either flooding the surface with water or, covering the surface with damp burlap and keeping it continuously moist for a minimum of 3 days or, spraying the surface with a liquid membrane curing compound.
- Use moderate slump (3 to 5 inches), air entrained concrete. Higher slump (up to 6 or 7 inches) can be used providing the mixture is designed to produce the required strength without excessive bleeding and/or segregation. Air entrainment helps to reduce the rate of bleeding of fresh concrete and thereby reduces the chance of crazing.

- NEVER sprinkle or trowel dry cement or a mixture of cement and fine sand into the surface of the plastic concrete to absorb bleed water. Remove bleed water by dragging a garden hose across the surface. DO NOT perform any finishing operation while bleed water is present on the surface.
- Dampen the subgrade prior to concrete placement to prevent it absorbing too much water from the concrete. If an impervious membrane, such as polyethylene, is required on the subgrade cover it with 1 to 2 inches of damp sand to reduce bleeding.

Chemical Attack

Exposure to Aggressive Chemicals, such as:

- Inorganic Acids
- Organic Acids
- Alkaline solutions
- Salt Solutions

Acid attack on concrete: Reaction between the acid and the calcium hydroxide of the hydrated Portland cement results in water soluble calcium compounds, which are leached away.

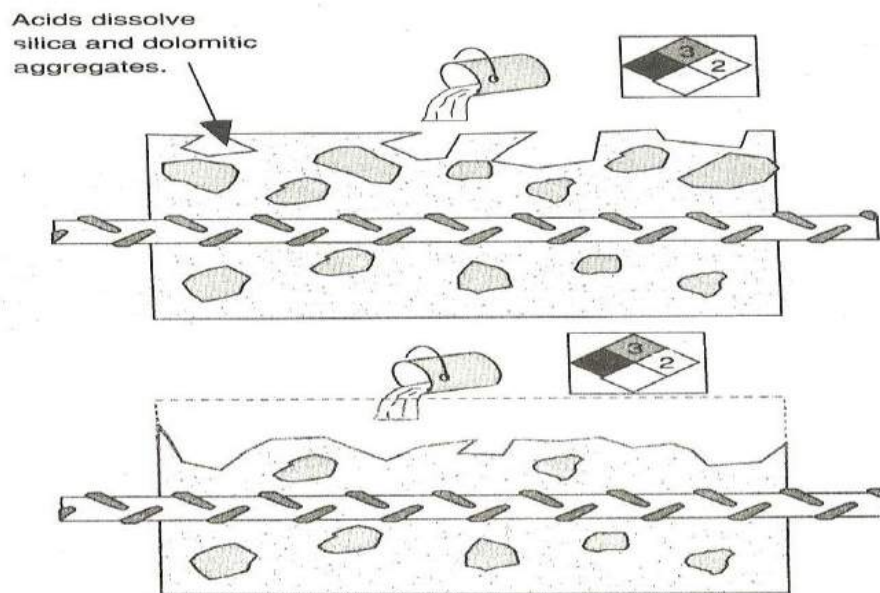

- When limestone or dolomitic aggregates are used then the acid dissolves them.
- *Dolomite* is a carbonate mineral composed of calcium magnesium carbonate - $\text{CaMg}(\text{CO}_3)_2$

Mechanism of Acid Attack

Concrete is susceptible to acid attack because of its alkaline nature. The components of the cement paste break down during contact with acids. Most pronounced is the dissolution of calcium hydroxide which occurs according to the following reaction:

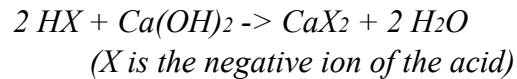

The decomposition of the concrete depends on the porosity of the cement paste, on the concentration of the acid, the solubility of the acid calcium salts (CaX_2) and on the fluid transport through the concrete. Insoluble calcium salts may precipitate in the voids and can slow down the attack.

Acids such as nitric acid, hydrochloric acid and acetic acid are very aggressive as their calcium salts are readily soluble and removed from the attack front.

Other acids such as phosphoric acid and humic acid are less harmful as their calcium salt, due to their low solubility, inhibits the attack by blocking the pathways within the concrete such as interconnected cracks, voids and porosity.

Sulphuric acid is very damaging to concrete as it combines an acid attack and a sulfate attack.

Visual effects of Acid Attack

An acid attack is diagnosed primarily by two main features (microscopic appearance):

- (1) Absence of calcium hydroxide in the cement paste
- (2) Surface dissolution of cement paste exposing aggregates

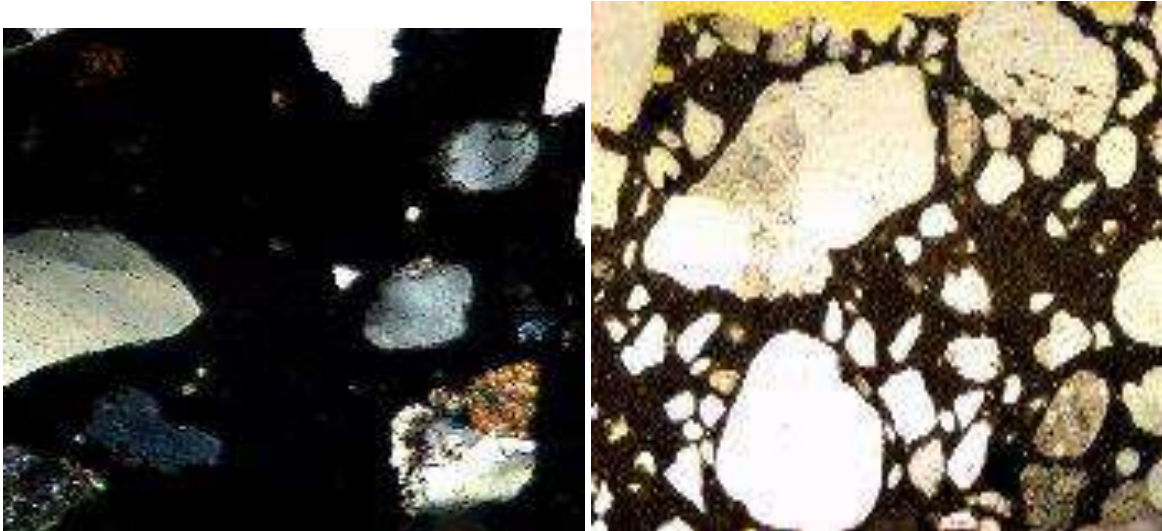

Preventive Measures

- Low water-cement ratio
- Low cement content to reduce the C-S-H
- Use of pozzolanic materials like micro silica, slag to reduce the calcium hydroxide content.
- Using epoxy-bonded replacement concrete or polymer concrete which does not contain Portland cement.

Alkali–aggregate reaction (AAR)

Aggregates in most of the Concrete are chemically inert. However, certain types of sand and aggregate such as opal, chert or volcanic with high silica content are reactive with the alkalis like calcium, sodium and potassium hydroxide present in Portland cement concrete. This phenomenon of chemical reaction is referred as alkali-aggregate reaction. This reaction can cause expansion of the altered aggregate, leading to spalling and loss of strength of the concrete.

The *alkali–aggregate reaction* is a general, but relatively vague expression. More precise definition are:

- Alkali–silica reaction(ASR)
- Alkali–silicate reaction and
- Alkali–carbonate reaction

Alkali Silica Reaction (ASR)

It is the reaction between the alkalis in cement and silica-containing aggregates. The ASR reaction is the same as the pozzolanic reaction, which is a simple acid-base reaction between calcium hydroxide, (Ca(OH)₂), and silicic acid (H₄SiO₄, or Si(OH)₄). This reaction can be schematically represented as following:



This reaction causes the expansion of the altered aggregate by the formation of a swelling gel of calcium silicate hydrate (C-S-H). This gel increases in volume with water and exerts an expansive pressure inside the material, causing spalling and loss of strength of the concrete, finally leading to its failure.

Mechanism

The mechanism of ASR causing the deterioration of concrete can be described in four steps as follows:

- The alkaline solution attacks the siliceous aggregate, converting it to viscous alkali silicate gel.

- Consumption of alkali by the reaction induces the dissolution of Ca^{2+} ions into the cement pore water. Calcium ions then react with the gel to convert it to hard C-S-H.
 - The penetrated alkaline solution converts the remaining siliceous minerals into bulky alkali silicate gel. The resultant expansive pressure is stored in the aggregate.
 - The accumulated pressure cracks the aggregate and the surrounding cement paste when the pressure exceeds the tolerance of the aggregate.
- The alkali-aggregate reaction may go unrecognized for some period of time, possibly years, before associate severe distress develops.

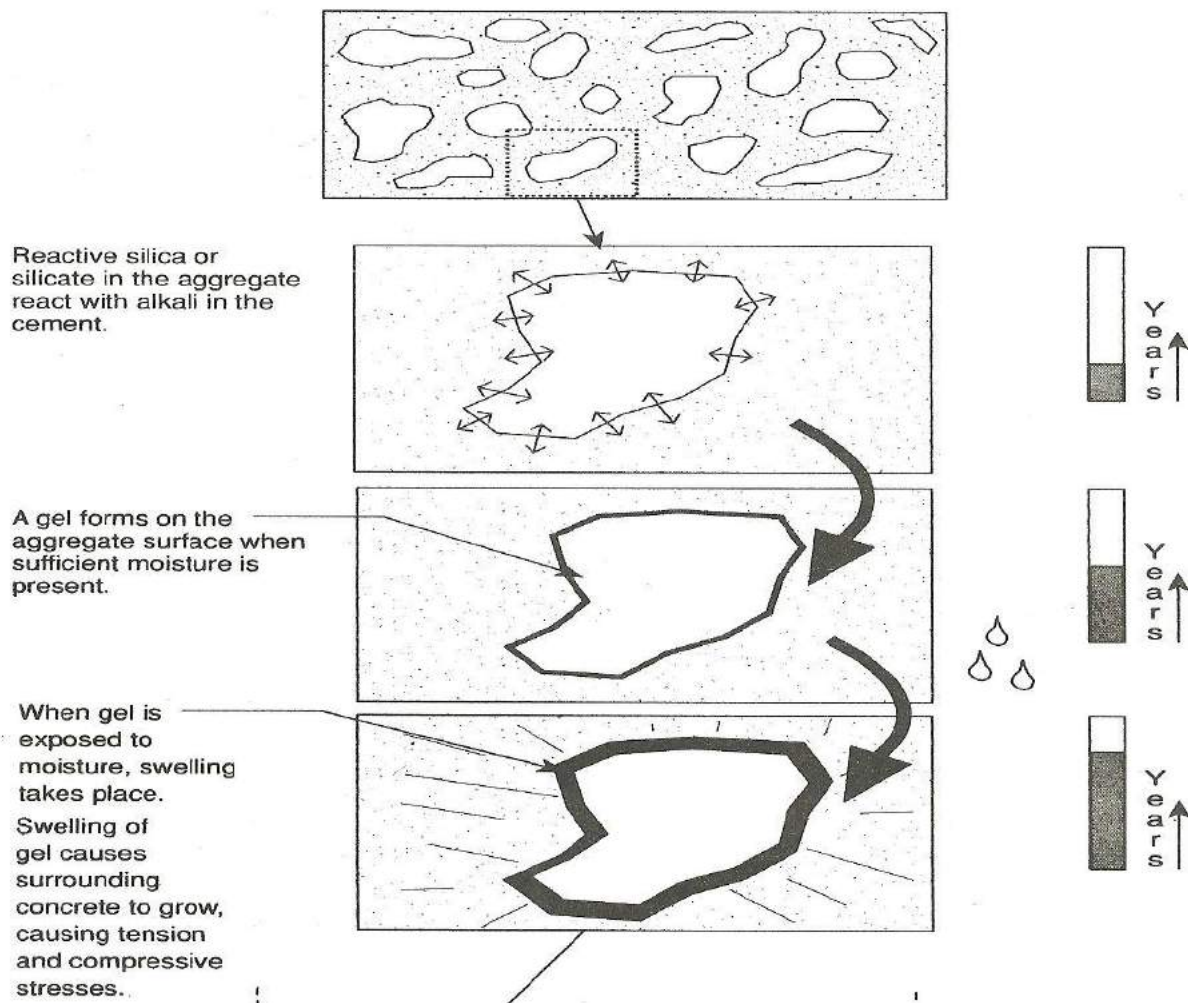

The effect of ASR can be traced by physical appearance like expansion and cracking in concrete impacting its structural strength, elasticity and durability, visible map cracking, pop-outs, spalling of concrete and expulsion of alkali-silica gel.



Typical effect of Alkali-Aggregate Reaction

Preventive measures

- Avoiding the use of reactive aggregates
- Use of low alkali Portland cement, slag cement or pozzolanic admixtures.
- The rate of expansion can be reduced by taking steps to maintain concrete in as dry state as possible by the use of surface coatings or impregnation material.

The repair of the concrete undergoing AAR should be carried out only after the expansion ceases because the continuing expansion will disrupt and destroy the repair material.

Alkali Silicate Reaction

In the alkali–silicate reaction, the layer of silicate minerals (clay minerals), sometimes present as impurities, are attacked,

Preventive measures

ASR can be controlled using certain supplementary cementitious materials. In proper proportions, silica fume, fly ash, and ground granulated blast-furnace slag have significantly reduced expansion due to alkali-silica reactivity. In addition, lithium compounds have been used to reduce ASR.

It is also important to note that not all ASR gel reactions produce destructive swelling.

Alkali Carbonate Reaction

The **alkali–carbonate reaction** is a process suspected for the degradation of concrete containing dolomite aggregate.

Alkali from the cement might react with the dolomite crystals present in the aggregate inducing the production of brucite, $(\text{MgOH})_2$, and calcite (CaCO_3). This mechanism was tentatively proposed by Swenson and Gillott (1950) and may be written as follows:

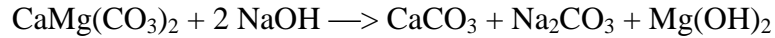

Brucite ($\text{Mg}(\text{OH})_2$), could be responsible for the volumetric expansion after de-dolomitisation of the aggregate, due to absorption of water.

ACR is relatively rare because aggregates susceptible to this phenomenon are less common and are usually unsuitable for use in concrete for other reasons. Aggregates susceptible to ACR tend to have a characteristic texture that can be identified by petrographers.

Sulphate Attack

Sulfate attack is a chemical breakdown mechanism where sulfate ions attack components of the cement paste.

The compounds responsible for sulfate attack are water-soluble sulfate-containing salts, such as alkali-earth (calcium, magnesium) and alkali (sodium, potassium) sulfates that are capable of chemically reacting with components of concrete.

Sulfate sources:

Internal Sources:

This is more rare but, originates from such concrete-making materials as hydraulic cements, fly ash, aggregate, and admixtures.

- portland cement might be over-sulfated.
- presence of natural gypsum in the aggregate.
- Admixtures also can contain small amounts of sulfates.

External Sources:

External sources of sulfate are more common and usually are a result of high-sulfate soils and ground waters, or can be the result of atmospheric or industrial water pollution.

- Soil may contain excessive amounts of gypsum or other sulfate.
- Ground water be transported to the concrete foundations, retaining walls, and other underground structures.
- Industrial waste waters.
- Atmosphere near the oceans may carry sulphate contents.

Mechanism

Sulphates react chemically with cement paste's hydrated lime and hydrated calcium aluminate to form calcium sulphate and calcium sulfoaluminate. They inevitably cause expansive distruption of concrete as the volume of by-products of reactions is greater than original volume of cement paste form which they are formed. The tensile stresses developed as a result of expansion lead to development of cracks in concrete. As a result, surface scaling and disintegration set in, followed by mass deterioration. The severity of the sulphate attack depends on the types of sulphates. Severity of the attack increases from calcium sulphate to sodium sulphate to magnesium sulphate. Sodium sulphate (Na_2SO_4) also reacts with calcium hydroxide to form gypsum, which reduces paste strength and stiffness. Magnesium Sulphate (MgSO_4) reacts to form gypsum and destabilizes the calcium silicate hydrate (C-S-H), the strength governing phase in cement paste.

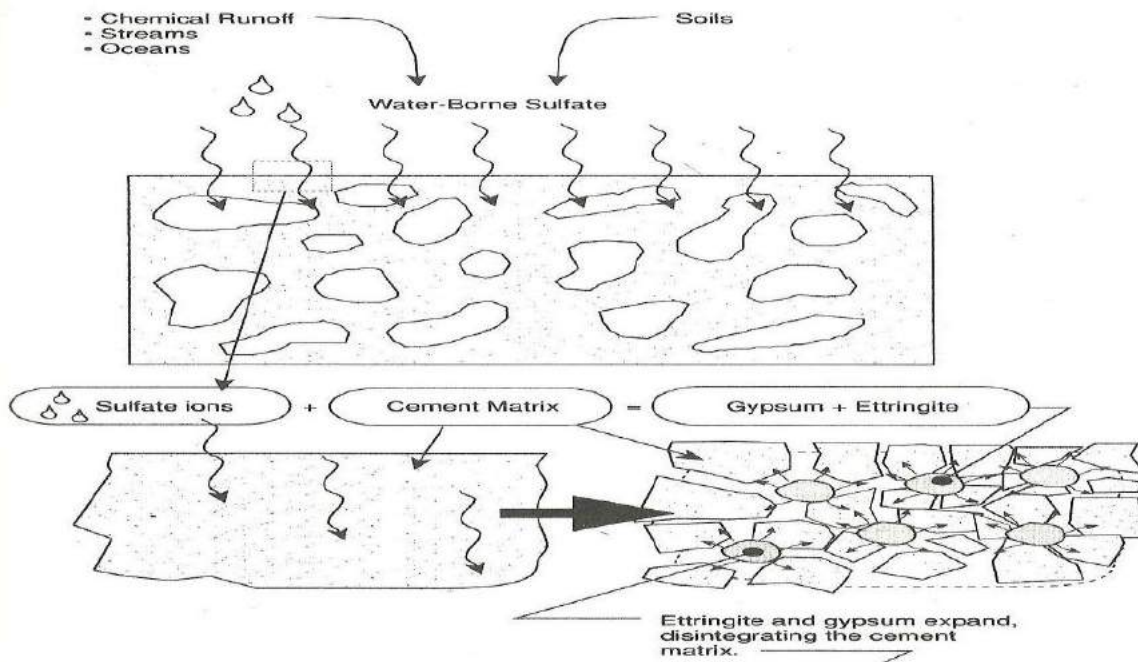

Mechanism of Sulphate Attack

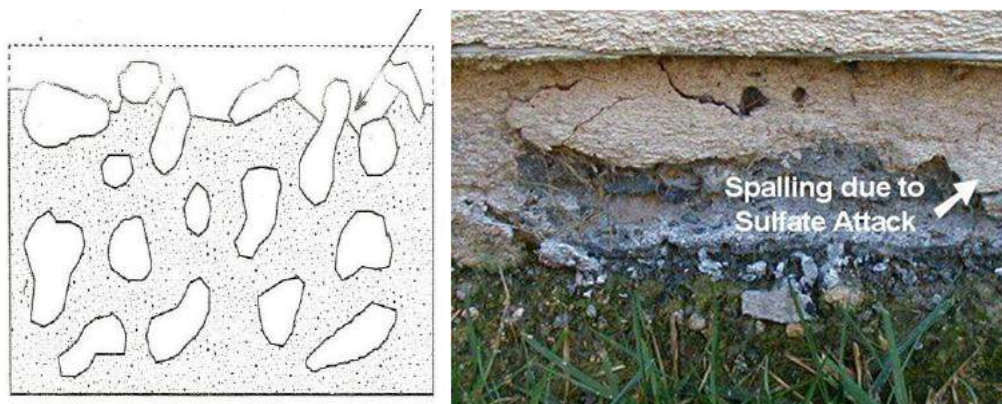

Factors affecting sulfate attack:

- The exposure conditions i.e., the amount of aggressive substance
- Permeability of concrete
- Amount of water available
- Type of cement in concrete
- Alternate wetting and drying cycles

The physical manifestation of sulphate attack includes a whitish appearance followed by surface scaling and disintegration.

Preventive measures

The quality of concrete, specifically a low permeability, is the best protection against sulfate attack. The concrete must have the following other characteristics:

- (a) Adequate concrete thickness
- (b) High cement content – with low tricalcium aluminate
- (c) Low w/c ratio
- (d) Proper compaction and curing
- (e) Proper proportions of admixtures such as silica fume, fly ash and ground slag improve resistance against sulfate attack.
- (f) reducing the amount of reactive elements such as calcium that is needed for expansive sulphate reactions.

Cement Carbonation

Carbonation: Carbonation is the formation of calcium carbonate (CaCO₃) by a chemical reaction in the concrete.

The creation of calcium carbonate requires three equally important substances: carbon dioxide (CO₂), calcium phases (Ca), and water (H₂O). Carbon dioxide (CO₂) is present in the surrounding air, calcium phases (mainly Ca(OH)₂ and CSH) are present in the concrete, and water (H₂O) is present in the pores of the concrete.

The first reaction is in the pores where carbon dioxide (CO₂) and water (H₂O) react to form carbonic acid (H₂CO₃):



The carbonic acid then reacts with the calcium phases:

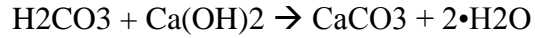

Once the $\text{Ca}(\text{OH})_2$ has converted and is missing from the cement paste, hydrated CSH (Calcium Silicate Hydrate - $\text{CaO}\cdot\text{SiO}_2\cdot\text{H}_2\text{O}$) will liberate CaO which will then also carbonate:

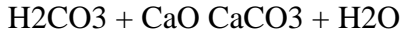

Mechanism

When these reactions take place the pH value will start falling. The normal pH-value of concrete is above 13 and the pH-value of fully carbonated concrete is below 9.

Once the carbonation process reaches the reinforcement, and the pH-value drops beneath 13 the passive "film" on the re-bars will deteriorate and corrosion will initiate on the reinforcement.

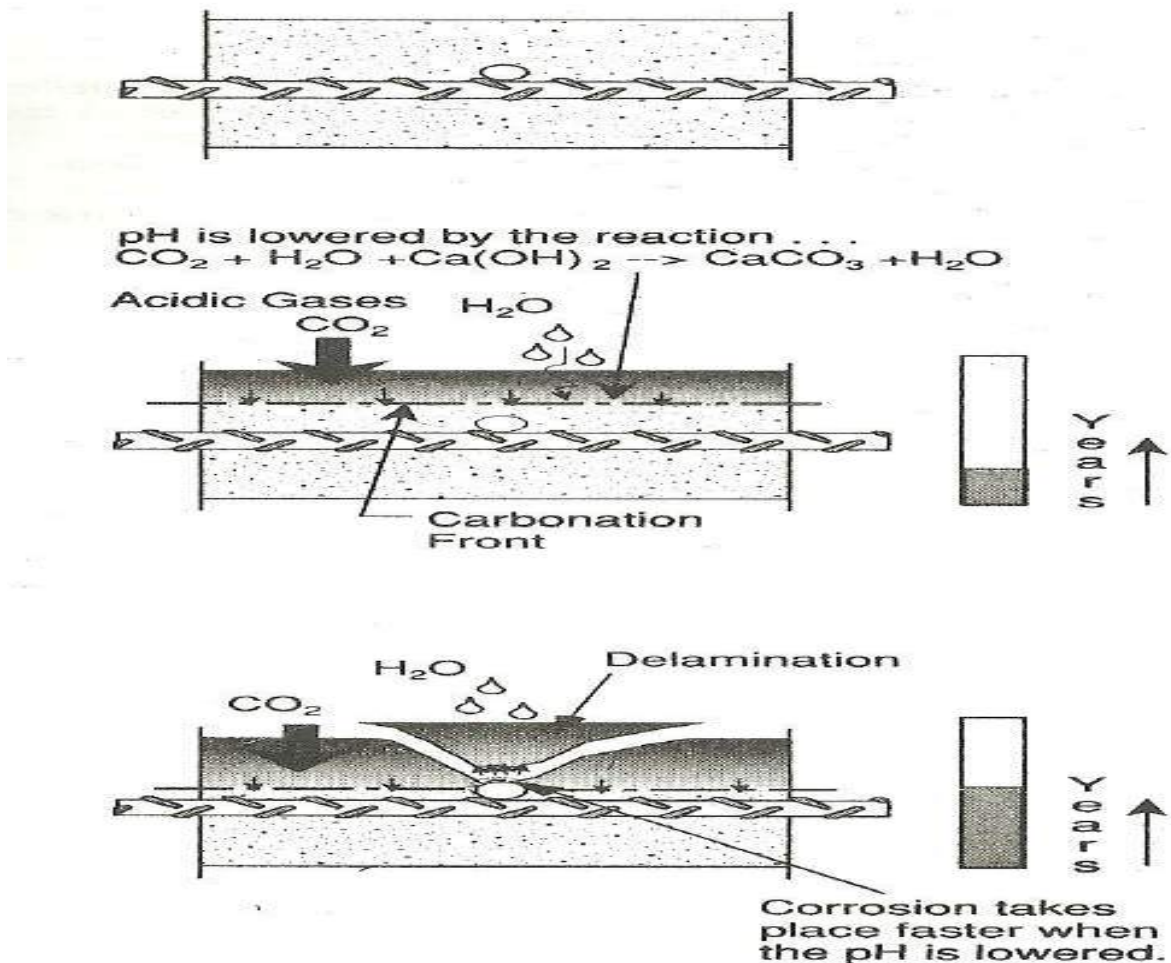

The speed of the carbonation process through the concrete mainly depends on two parameters:

- The porosity of the concrete

- The moisture content of the concrete

In good quality concrete, the carbonation process is slow. Lesser the porosity lesser the penetration of CO₂. The carbonation process requires constant change in the moisture levels (dry to damp to dry). The process does not occur when concrete pores are filled with water – or when concrete is constantly underwater.

Corrosion:



Thermal Cause

1. Freeze Thaw Disintegration

Concrete is porous, so if water gets in and freezes it breaks off small flakes from the surface. Deicing salts make it worse. This is typically called scaling and it can occur during the first winter and get worse over time. When severe, it can lead to complete destruction of the concrete.

Freeze-Thaw disintegration takes place due to:

- (a) Freezing and thawing temperature cycles within the concrete
- (b) Porous concrete that absorbs water.

Generally occurs on horizontal surfaces that are exposed to water or on the vertical surfaces on the water line in submerged structures.



Mechanism

The freezing water contained in the pore structure expands as it converts to ice. The expansion causes local tension forces that fracture the surrounding concrete matrix. The fracturing occurs in small pieces, working from outer surfaces inward.

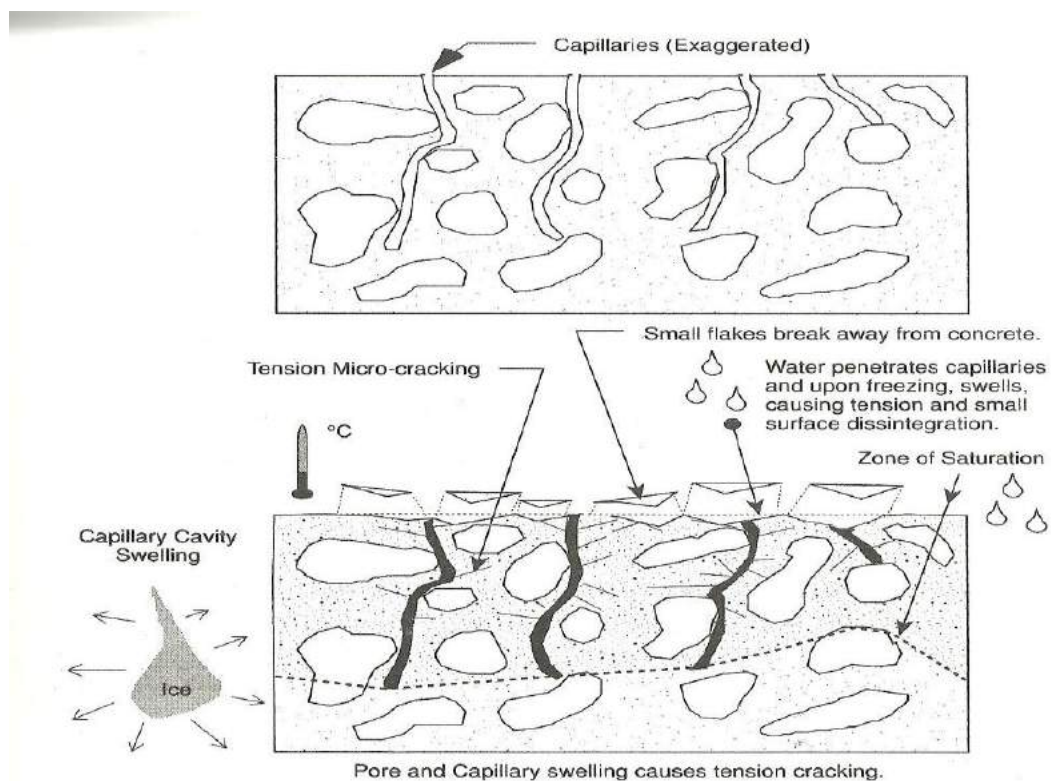

Macro & Microscopic Appearance

Deterioration of concrete by freeze thaw actions may be difficult to diagnose as other types of deterioration mechanisms such as ASR often go hand in hand with Freeze&Thaw (F/T). The typical signs of F/T are:

- Spalling and scaling of the surface
- Large chunks (cm size) are coming off
- Exposing of aggregate
- Usually exposed aggregate are un-cracked
- Surface parallel cracking
- Gaps around aggregate - in the ideal case



The rate of freeze-thaw deterioration is the function of:

- Porosity (increases rate)
- Moisture saturation (increases rate)
- Number of freeze-thaw cycles (increases rate)
- Air entrainment (reduces rate)
- Horizontal surfaces that trap standing water (increases rate)
- Aggregate with small capillary structure and high absorption (increases rate)

Preventive Measures

To protect concrete from freeze/thaw damage, it should be air-entrained by adding a surface active agent to the concrete mixture. This creates a large number of closely spaced, small air bubbles in the hardened concrete. The air bubbles relieve the pressure build-up caused by ice formation by acting as expansion chambers. About 4% air by volume is needed and the air-bubbles should be well distributed and have a distance between each other of less than 0.25 mm in the cement paste.

2. Temperature Variation:

Temperature Variation leads to Volume Changes in concrete. Resulting stresses lead to cracking, spalling and excessive deflections. Thermal Coefficient of concrete = 9×10^{-6} mm/mm/°C

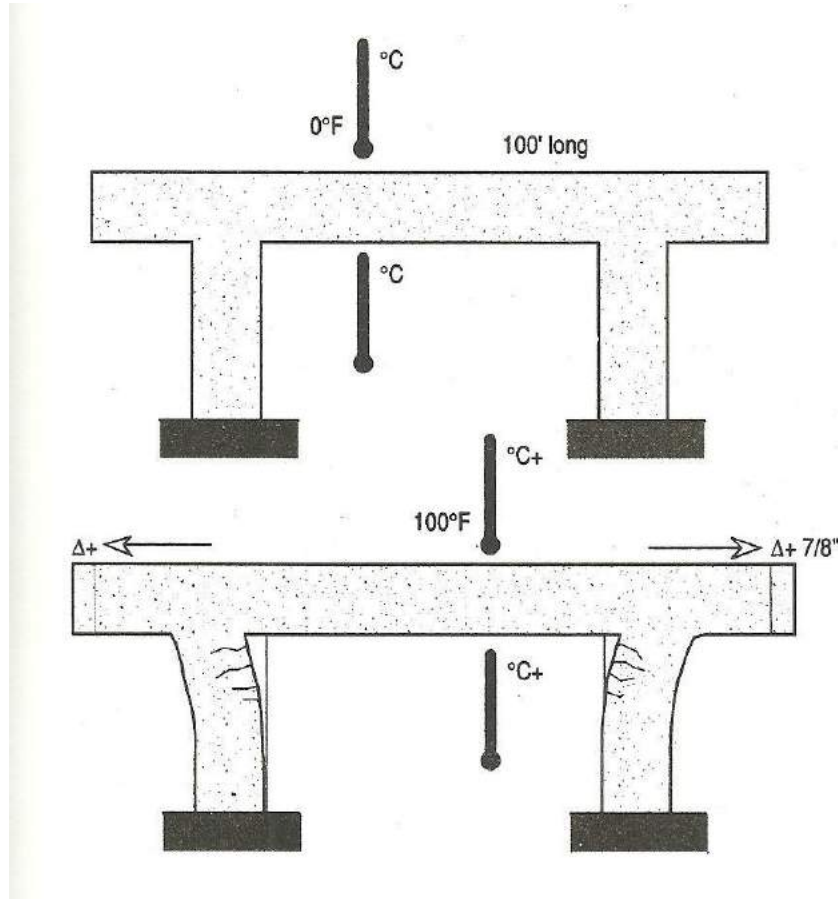

Thermal Volume change leading to Shear Cracks

Solar Heating effects the structure based on its configuration. In simple span structures only up and down deflections take place and the joints are free to rotate. In continuous span structures, hinges may form due to joint rotation being restrained. These hinges open and close with daily temperature. Stress build-up in restrained structures may result in tension cracks, shear cracks or even buckling at the weakest location.

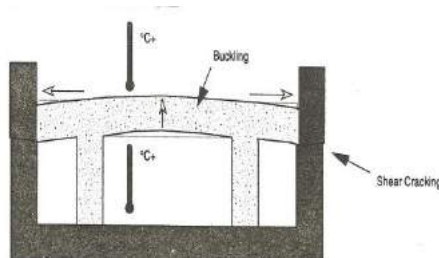

Deterioration due to abrasion, erosion, cavitations and crystallization of salt

in pores: Progressive loss of mass from a concrete surface can occur due to abrasion, erosion and cavitation.

Abrasion: It is wearing away of the surface by dry attrition, repeated rubbing, rolling, sliding or frictional process. Surface abrasion is mainly caused by dry attrition as in pavements and industrial floors due to heavy trucking and vehicles. In hydraulic structures, the abrasion occurs due to the cutting action of water borne debris, the suspended solids in water i.e., rolling, sliding and grinding of debris suspended in water against the concrete structures. The factors that effect the abrasion resistance of concrete include compressive strength, aggregate properties, finishing methods, use of toppings and curing.

Erosion: It refers to manifestation of wear on the concrete surface by the abrasive actions of the suspended solid particles in fluids. The impinging, sliding, rolling action of suspended solid particles in water that come in contact with the concrete causes the surface wear. The rate of erosion depends on porosity and strength of concrete, duration of exposure, flow velocity of the water and its direction, and the amount, size, shape, density, hardness and velocity of the water borne debris.

Cavitation: It is the damage that is caused to concrete by action of high velocity water. Concrete generally shows excellent resistance to the latter, however, cavitation damage occurs when high velocity water-flows encounters discontinuities on the surface. Discontinuities, in the form of surface misalignment or abrupt change in slope, in the flow path cause the water to lift off the flow surface, creating negative pressure zones and resulting in the formation of bubbles of water vapour. These bubbles flow downstream with the water. On entering the region of high pressure, they collapse with great impact. Such high impacts can remove the particles of concrete, forming another discontinuity that creates more extensive damage. Cavitation damage results in erosion of the cement matrix, leaving harder aggregate in place.

Crystallization of salt in pores: Concrete structures when exposed to alternate wetting and drying cycles, as in case of marine structures, can result into a crystallization of salts in the pores causing stress that can damage the concrete structures. During drying, the pure water from the surface gets evaporated. Salts that are present in the sea water are left behind in the form of crystals. During the cycle of wetting, these crystals go on growing on subsequent re-wetting and as a result they keep exerting force on hardened cement paste surrounding it. Similarly, salts in ground water or damp soil get transported vertically to a concrete member through the capillary action. Above ground level, the moisture is drawn to the surface and evaporates, leaving crystals of salt growing in the surface pores, which on re-wetting grow and expand.

Structural Cause

Accidental overload

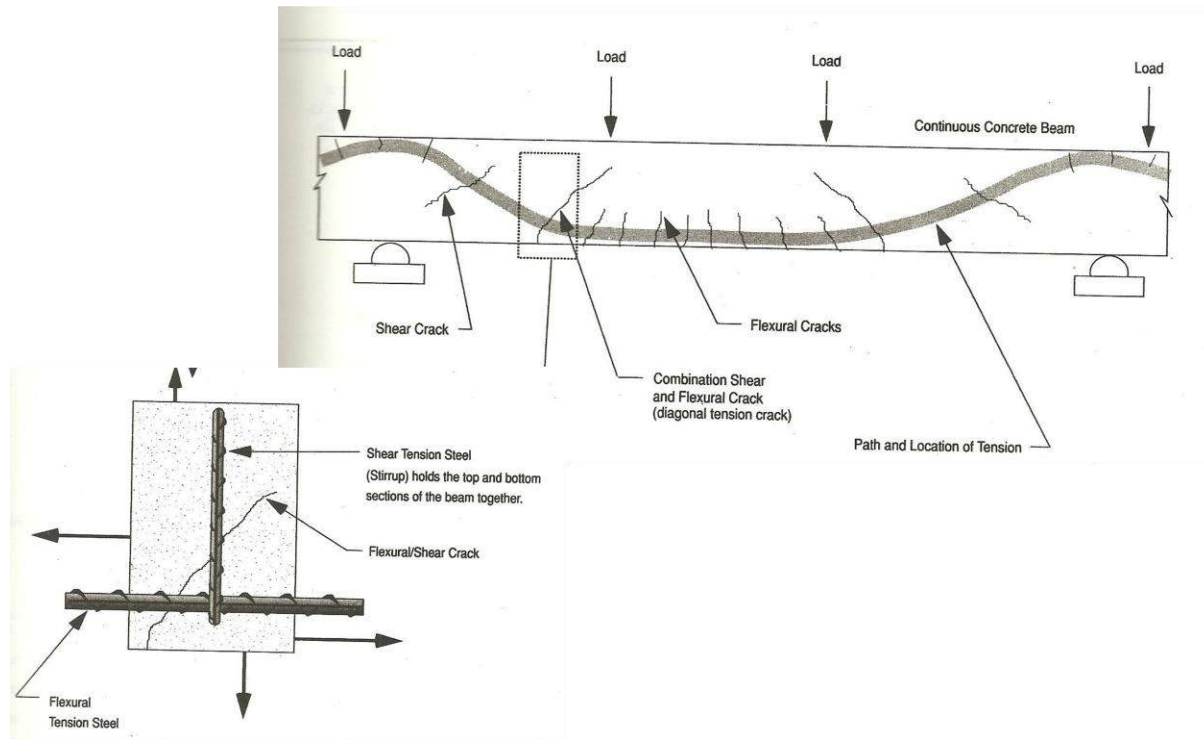
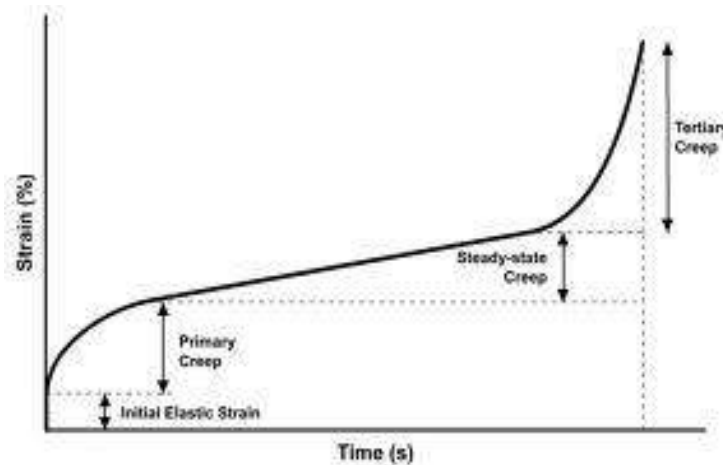
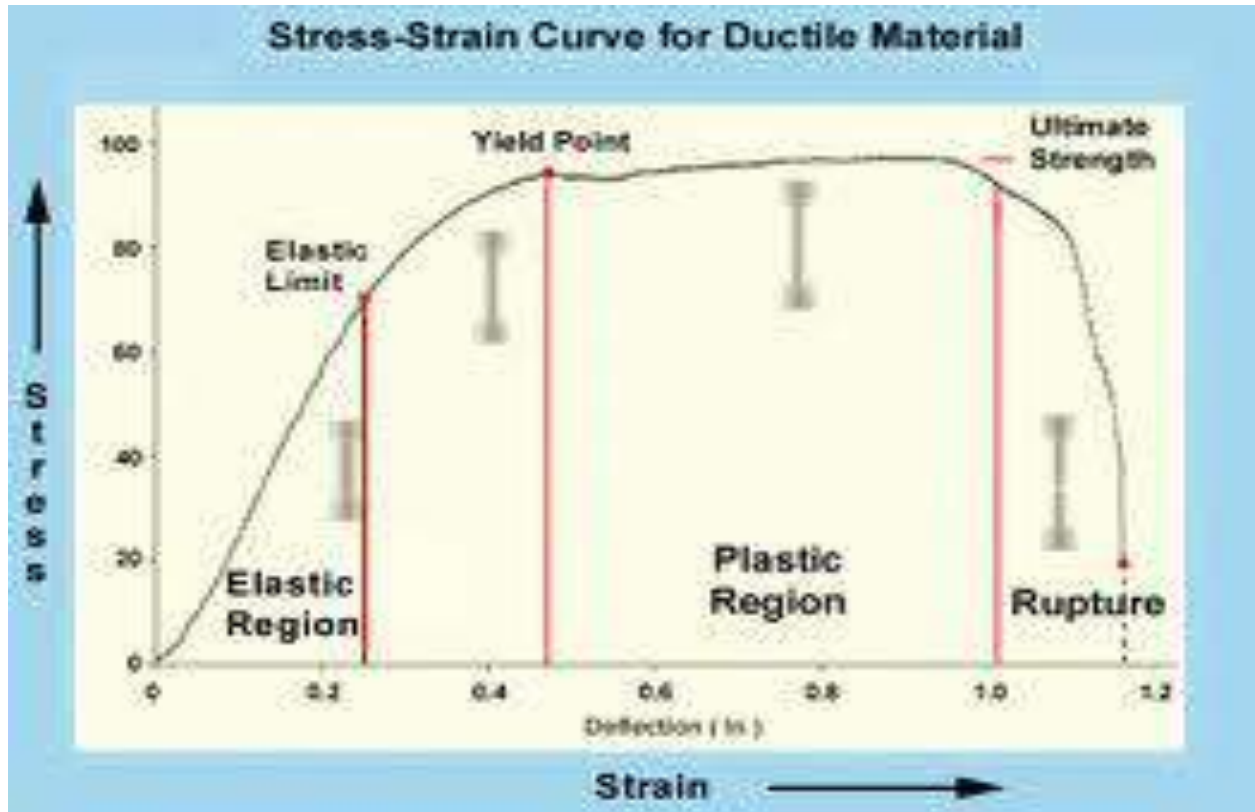

Fig. Cracking Modes in Continuous Span

Creep

Creep is the 'time-dependent' part of the strain resulting from stress. In other words, creep is the increase in strain under sustained stress.





Mechanism

Under sustained stress and with time, the hydrated cement gel, the adsorbed water layer, the water held in the gel pores and the capillary pores yields, flows and readjust themselves, resulting in shrinkage of concrete.

Causes of creep

Influence of aggregate: Stronger aggregate of high modulus of elasticity and a larger aggregate content in concrete mix reduces the magnitude of creep. Creep is the 'time-dependent' part of the strain resulting from stress.

Mix Proportions: Creep increases with increase in w/c ratio. Creep is inversely proportional to the strength of the concrete.

Influence of age: In a broad sense, the age at which the concrete is loaded has predominant effect on creep. Cement gel quality improves with time. Stresses induced on young concrete will result in large creep.

Time and the magnitude of stress are main factors affecting creep.

Effects of Creep

- Unwanted deflections in reinforced concrete beams
- In columns, creep in concrete will transfer greater load on to the reinforcing steel bars.
- In eccentrically loaded columns, creep increases the deflection and can lead to buckling.
- In mass concrete structures, creep accompanied by differential interior temperature conditions can cause cracking of the concrete.
- In pre-stressed concrete, creep reduces the pre-stressing magnitude.

TOPIC 2: Corrosion of Steel Reinforcement & protective coatings

Syllabus: Corrosion of steel reinforcement-causes-mechanism and prevention, Damage of Structures due to fire-fire rating of structures-phenomena of desiccation

Steel by nature is thermodynamically unstable in earth's atmosphere and has inherent tendency to revert to more stable compounds such as oxide or hydroxide by reaction with oxygen and water. But as the steel is embedded in concrete which is a high alkaline - pH of fresh concrete is between 12 and 13. In this range of alkalinity, embedded steel is protected from corrosion by a passivating film bonded to the reinforcing bar surface. However, corrosion takes place when this passivating film is disrupted, through carbonation or ingress of aggressive chloride ions because this passive film is not stable in the solution containing chlorides or at pH levels below 9. Active corrosion starts when the passive film breaks down owing to the actions by chlorides or carbonation of concrete. It is responsible for much of the deterioration of reinforced concrete structures. Oxides and hydroxides of iron, produced during this process have volumes much greater than that of original metallic ions and hence it causes building up of tensile stresses within the concrete leading to further cracking/delamination and acceleration of corrosion process. The signs of corrosion can be identified by rust stains and minute cracking over the concrete surface.

Factors contributing to corrosion

External factors

- Availability of oxygen and moisture at rebar level
- Carbonation and entry of gaseous pollutants that reduce the pH of concrete
- Ingress of chloride ions
- Stay currents
- Relative humidity and temperature

Internal Factors

- Cement composition- Adequate amount of cement helps to maintain the pH of concrete in the range of 12.5 and 13
- Impurities in aggregate- Aggregates containing chloride salts
- Impurities in mixing or curing water
- Water/cement ratio- It has no direct bearing, but permeability is the function of w/c ratio. Increase in w/c ratio increases the permeability of concrete which in turn increases the penetration depths of chlorides, carbon dioxide and oxygen diffusion in concrete.
- Aggregate size and grading- large sized aggregate increase permeability. Coarse aggregate and fine aggregate must be appropriately proportioned in order to have a compact mass.

- Poor construction practices
- Use of admixtures like CaCl_2
- Inadequate cover to reinforcement

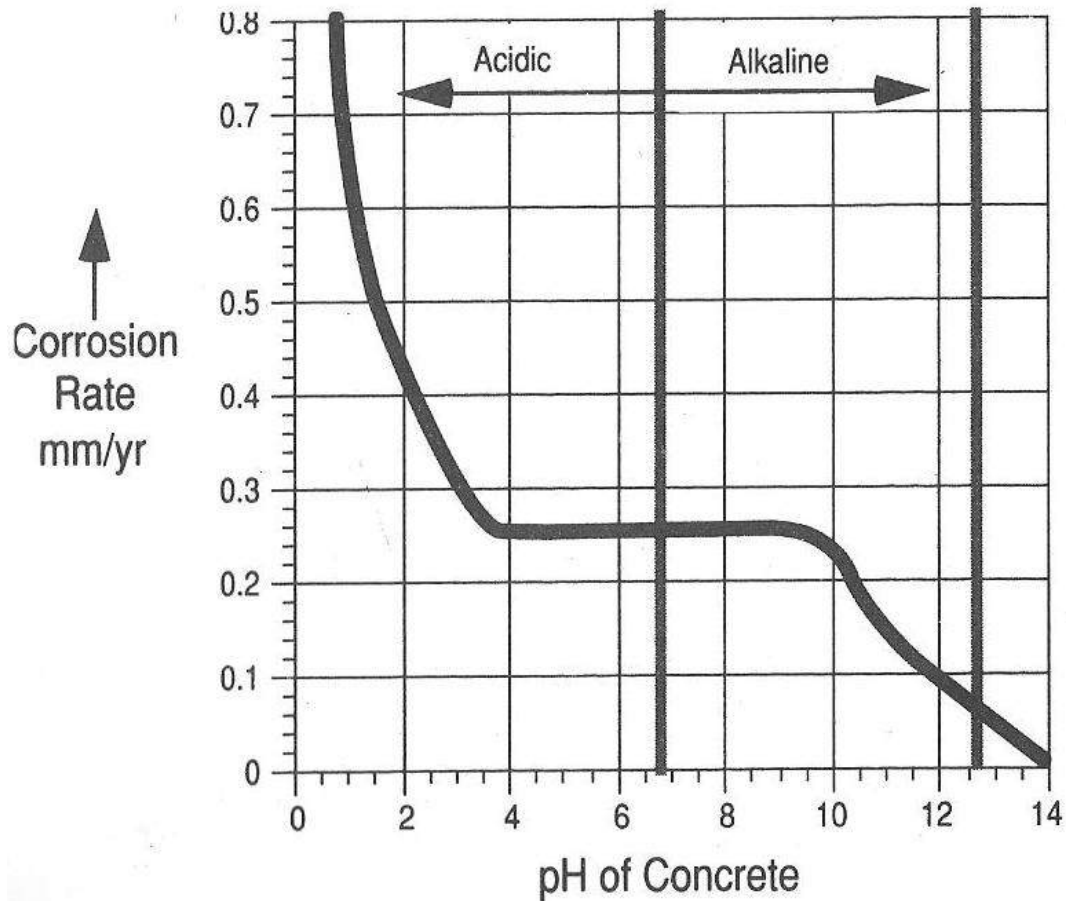

Fig. 1 Metal Corrosion is highly dependent on the pH of concrete

Mechanism of Corrosion: The corrosion process that takes place in concrete is electrochemical in nature very similar to a battery. The mechanism of corrosion involves four basic elements

Anode: Site where metal atoms lose electrons i.e., where corrosion is initiated.

Cathode: Site where electrons flow to and combine with other metallic and non-metallic ion.

Electrolyte: A medium capable of conducting electric current by ionic current flow.

Metallic path: Connection between the anode and cathode that completes the circuit.

At, anode the oxidation process releases Fe^{++} ions to concrete pore solution which flows to cathode to combine with hydroxyl ions to form Ferrous hydroxide, $\text{Fe}(\text{OH})_2$. In highly alkaline

solution and in absence of chloride ions, the anodic dissolution reaction of iron is balanced by the cathodic reaction. Fe^{2+} ions combine with OH^- ions to produce the stable passive film.

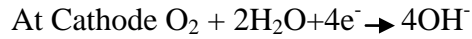
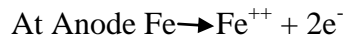

An electrochemical process requires an anode, cathode and an electrolyte. Moist Concrete forms an Electrolyte. Steel reinforcement provides anode and cathode

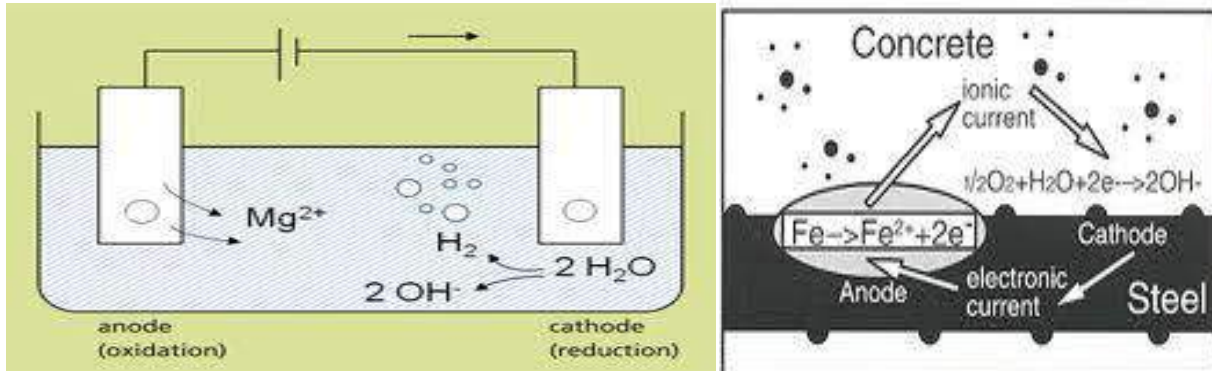

Electrical current flows between the cathode and anode, and the reaction results in an increase in metal volume as the Fe (Iron) is oxidized into $\text{Fe}(\text{OH})_2$ and $\text{Fe}(\text{OH})_3$ and precipitates as FeO OH (rust color). Water and oxygen must be present for the reaction to take place.

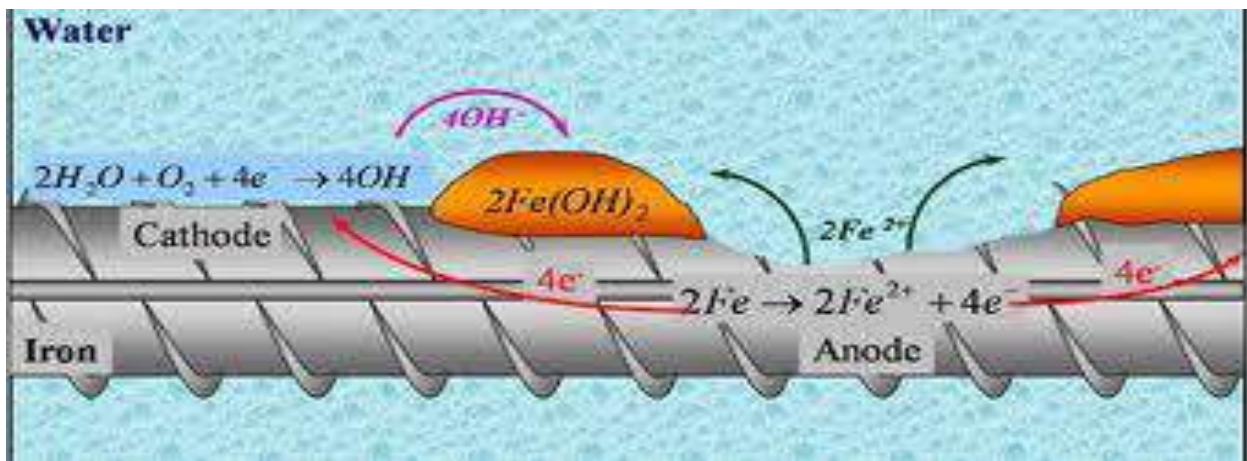

In good quality concrete the corrosion rate will be slow.

Accelerated corrosion will take place if

- the pH (alkalinity) is lowered (carbonation)
- if aggressive chemicals or dissimilar metals are introduced into the concrete

- presence of stray electrical currents and concentration cells caused by an uneven chemical environment.

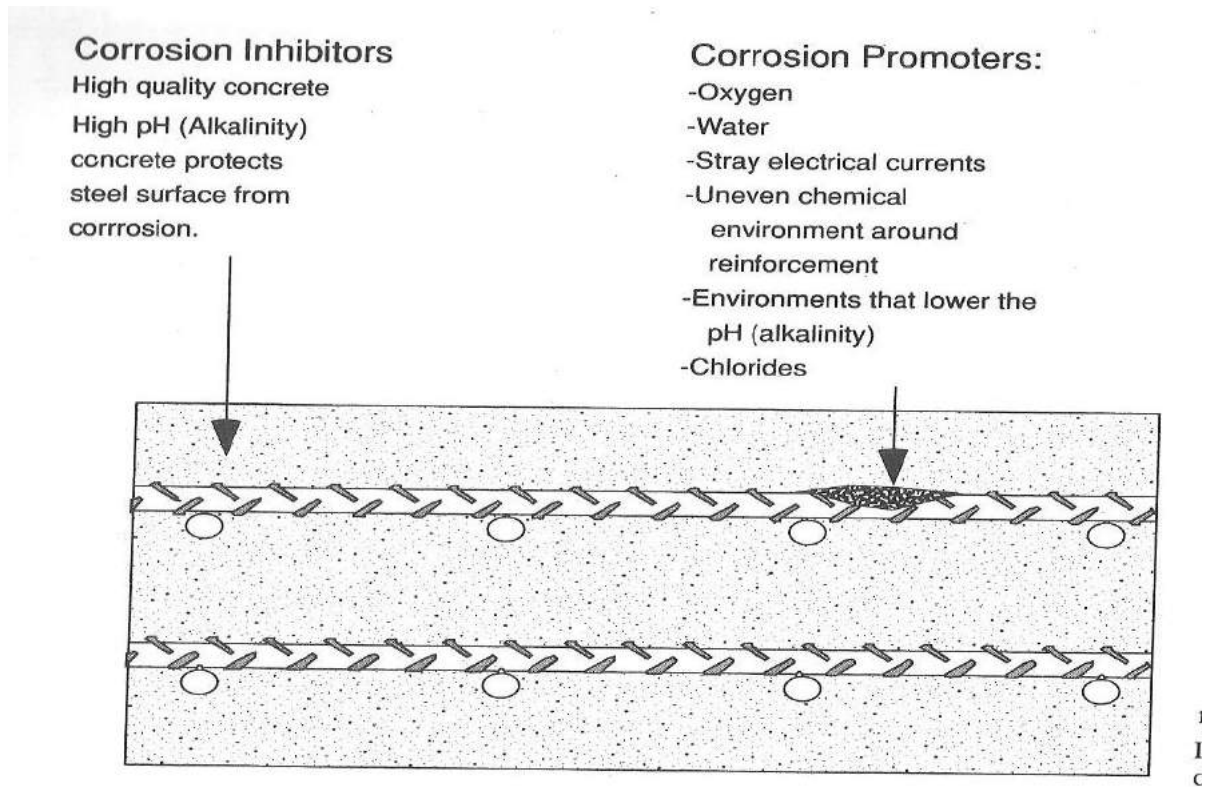

Chloride induced corrosion

Source of Chlorides:

Environments containing chlorides, such as sea water or de-icing salts.

Penetration rate of chlorides into concrete depends on:

- ❖ The amount of chlorides coming into contact with concrete.
- ❖ The permeability of the concrete.
- ❖ The amount of moisture present.

Mechanism

This type of corrosion in structural concrete is primarily caused by the presence of sufficient free chloride ions in the mix. The chloride induced corrosion is caused by the localized breakdown of the passive film on the reinforcing steel. According to one of the proposed hypothesis, the Cl^- ions compete with OH^- anions for combining with Fe^{2+} cations to form soluble complexes. These soluble iron-chloride complexes diffuse away from the steel where they break down, resulting in

the formation of expansive corrosion products and simultaneously freeing the Cl^- ions. The free chloride ions transverse back to the anode to react further with steel. In the entire process, the OH^- ions are continuously consumed, thereby locally decreasing the pH and enhancing the metal dissolution. The reaction becomes autocatalytic and proceeds with deepening of the corrosion pits rather than spreading the corrosion uniform along the bar.

It should be noted that, it is the concentration of the free chloride ions that greatly influences the process of corrosion. Chloride ions can find way into concrete either during the mixing or after the concrete has hardened. Some of these diffused chloride ions get trapped as water soluble chloride into the pore solution of concrete while remaining chloride ions get chemically bound with hydrate phase or the aluminate phase. Chloride ions that bind with the C_3A forms chloroaluminates that remains in non-reactive and insoluble form in the pore solution. This also means that cement containing high level of C_3A help to keep the bound chloride ions in non-reactive form hereby immobilizing them provided the concrete is uncarbonated. The reason being, carbonation of chloroaluminates releases the bound chloride making them free from reaction. The risk of corrosion is therefore associated with the threshold level of chloride concentration in carbonated as well as uncarbonated concrete.

Likelihood of corrosion is high in case of carbonated concrete irrespective of the level of chlorides content that may vary between less than 0.4% to more than 1.0%.

TABLE 2.2 Corrosion Risk in Case of Uncarbonated Concrete

Chloride (percentage by weight of cement)	Uncarbonated concrete	Likelihood of corrosion
<0.4%	Cement with less than 8% of C_3A	Moderate
	Cement with 8% or more C_3A	
0.4–1.0%	Cement with less than 8% of C_3A	High
	Cement with 8% or more C_3A	High
>1.0%	Irrespective of content of C_3A	Moderate
		High

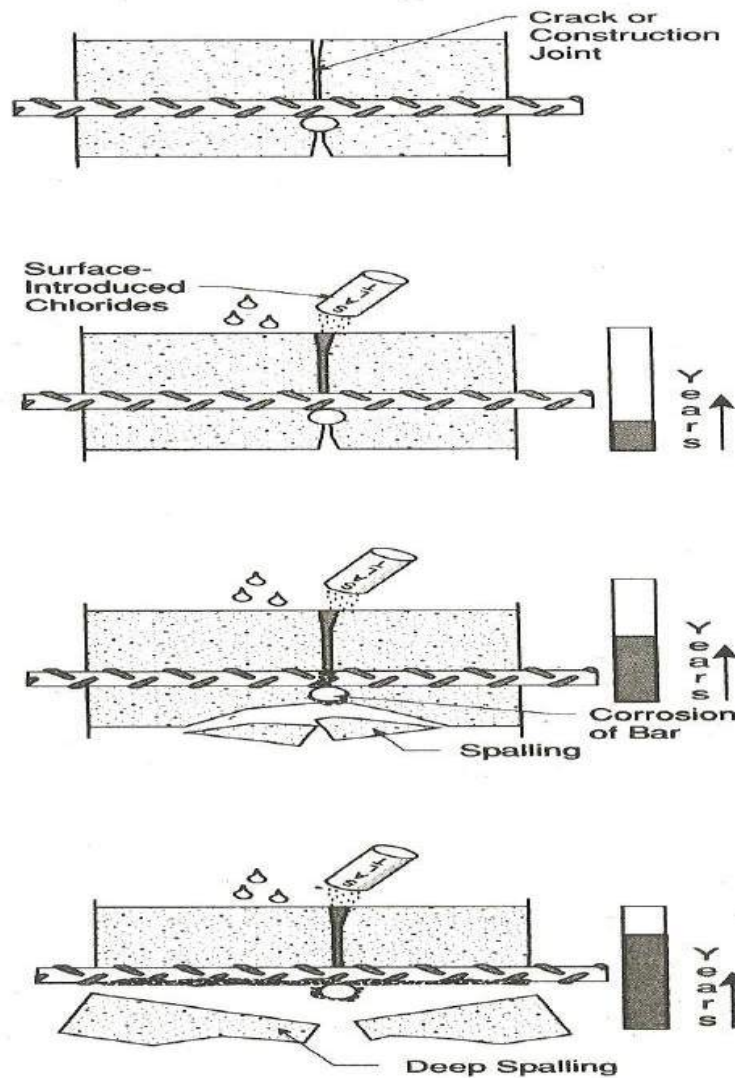

Influence of pH:

The concentration of chlorides necessary to promote corrosion is greatly affected by the concrete's pH. It was demonstrated that a threshold level of 8000 ppm of chloride ions was required to initiate corrosion when pH was 13.2. As the pH was lowered to 11.6 corrosion was initiated with only 71 ppm of chloride ions.

Cracks and construction joints in concrete permit corrosive chemicals such as de-icing salts to enter the concrete and access embedded reinforcing steel.

Cast-in chlorides

Chlorides cast into the concrete.

Chlorides may be introduced deliberately as an accelerator, or in the form of natural ingredients found in some aggregates.

Concrete made of beach sand or having seawater for mixing water will result in cast-in chlorides.

Chlorides occur in either water soluble or acid soluble form. Chlorides used as admixtures are water soluble, while those found in aggregate sources may be only acid soluble. Water soluble chlorides are the most damaging, since they readily become free to attack surrounding reinforcing steel.

Table 1 Tolerable crack widths to avoid rebar corrosion

Exposure Condition	Tolerable Crack Width	
	(In.)	(mm)
Dry air, protective membrane	0.016	0.41
Humidity, moist air, soil	0.012	0.30
De-icing chemicals	0.007	0.18
Seawater and seawater spray; wetting and drying	0.006	0.15
Water-retaining structures*	0.004	0.10

Table 2 Cast-in Chlorides limits suggested by ACI

Service condition	% of CI to weight of cement
Prestressed concrete	0.06
Conventionally reinforced concrete in a moist environment and exposed to chloride	0.10
Conventionally reinforced concrete in a moist environment not exposed to chloride	0.15
Above-ground building construction where concrete will stay dry	No limit

Carbonation induced corrosion

Carbonation is the formation of calcium carbonate (CaCO_3) by a chemical reaction in the concrete. The creation of calcium carbonate requires three equally important substances: carbon dioxide (CO_2), calcium phases (Ca), and water (H_2O). Carbon dioxide (CO_2) is present in the surrounding air, calcium phases (mainly $\text{Ca}(\text{OH})_2$ and CSH) are present in the concrete, and water (H_2O) is present in the pores of the concrete. When these reactions take place the pH value will start falling. The normal pH-value of concrete is above 13 and the pH-value of fully carbonated concrete is below 9. Once the carbonation process reaches the reinforcement, and the pH-value drops beneath 13 the passive "film" on the re-bars will deteriorate and corrosion will initiate on the reinforcement.

The reaction is as follows:

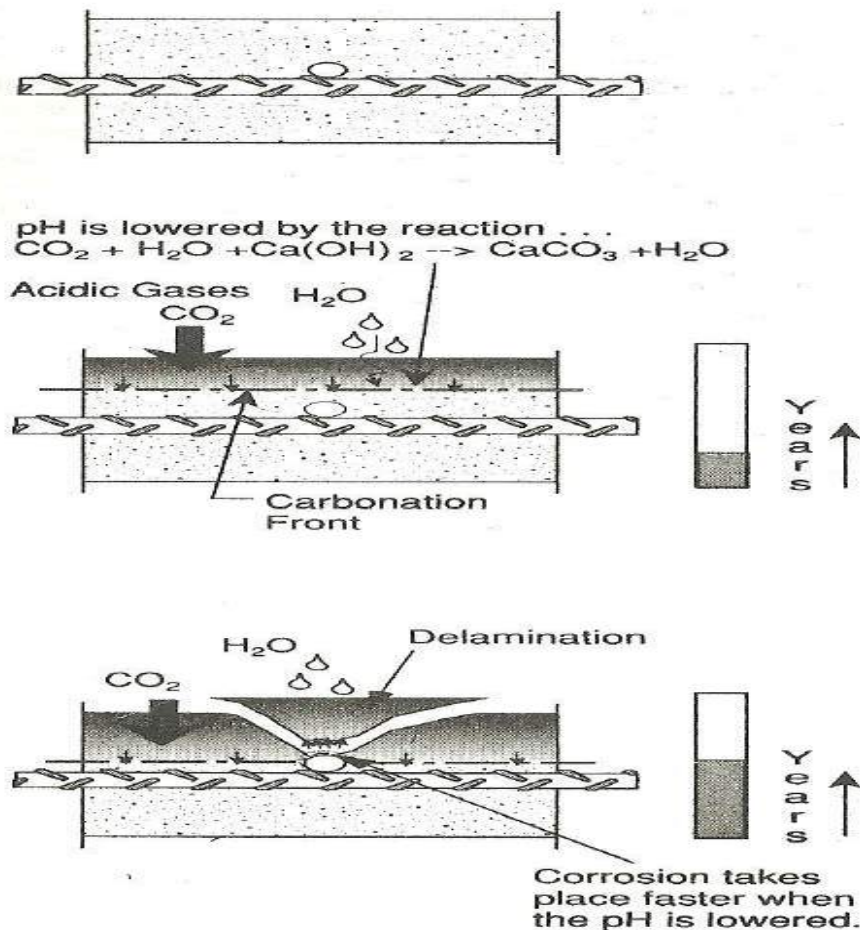
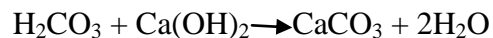
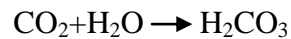

Carbonation of concrete is more in areas where the concentration of CO₂ is high and relative humidity is moderate in the range of 50-60%. The rate of carbonation increases with an increase in the concentration of carbondioxide, especially in concrete with high water-cement ratio and adequate moisture creating the carbonic acid agent. Diffusion of gaseous products cannot occur in complete wet or dry concrete. Intermittent exposure to water, i.e., due to rains, alternate wetting and drying accelerates the carbonation, hence the corrosion. In good quality concrete, the carbonation process is very slow. It has been estimated that the process will proceed at a rate up to 0.04in. (1mm) per year. The process requires constant change in moisture levels from dry to damp to dry.

Dissimilar Metal corrosion

Corrosion can take place in concrete when two different metals are cast into a concrete structure, along with an adequate electrolyte. A moist concrete matrix provides for a good electrolyte. Different metals have different rates of electrochemical activity

Below is a list of metals in increasing order of activity:

1. Zinc
2. Aluminum
3. Steel
4. Iron nickel
5. Tin
6. Lead
7. Brass
8. Copper
9. Bronze
10. Stainless steel
11. Gold

When two metals are in contact via an active electrolyte, the less active metal (lower number) in the series is corroded. One of the most common situations found in concrete is the use of aluminum cast into reinforced concrete. Aluminum has less activity than steel; therefore, the aluminum is the metal that corrodes. The steel will actually become cleaned, and the aluminum surfaces will grow a white oxide, which will cause tensile forces to crack the surrounding concrete.

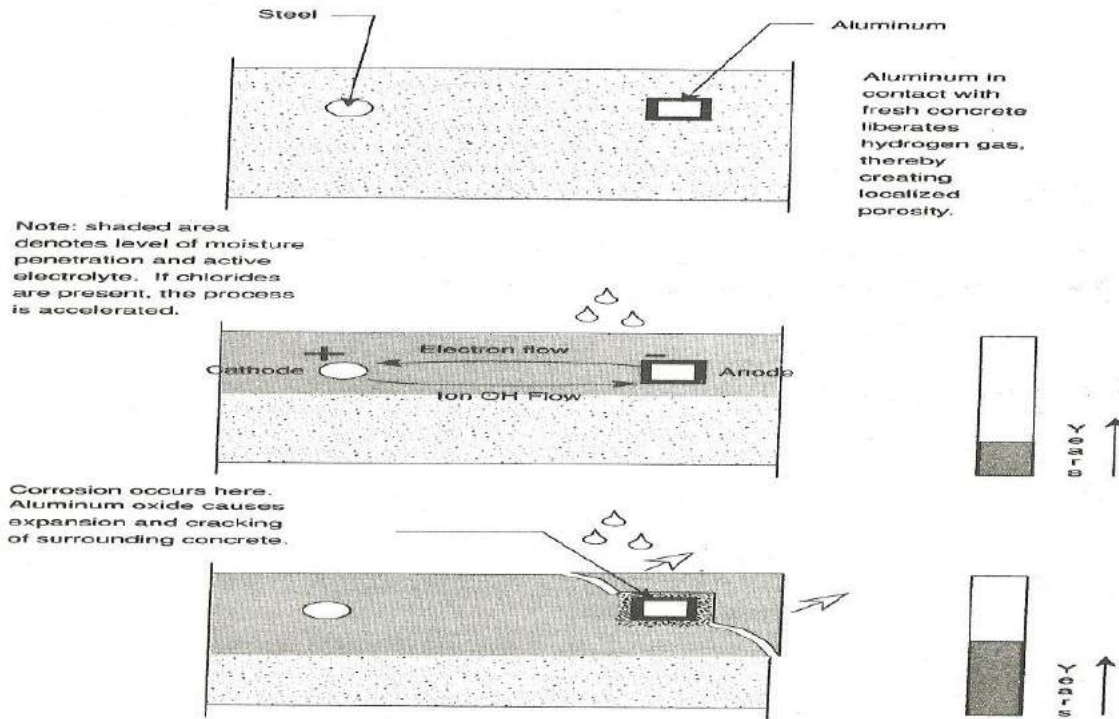

Effects of corrosion

- **Cracking & Spalling:** In compressive members, cracking and spalling of concrete reduces the effective cross section of the concrete, thereby reducing the ultimate compressive load capacity.
- **Reduction of structural capacity:** The research conducted on flexural beams found that in steel with more than 1.5 percent corrosion, the ultimate load capacity began to fall, and at 4.5 percent corrosion, the ultimate load was reduced by 12 percent probably as a result of reduced bar diameter.

Factors effecting cracking and spalling

1. Concrete tensile strength
2. Quality of concrete over the reinforcing bar
3. Bond or condition of the interface between the rebar and surrounding concrete.
4. Diameter of the reinforcing bar
5. Percentage of corrosion by weight of the reinforcing bar.

With the cover-to-bar diameter ratio (C/D) of 7, concrete cracking starts when corrosion reaches 4 percent, whereas, with a (C/D) ratio of 3, only 1 percent corrosion is enough to crack the concrete.

C/D Ratio	Cover in./mm	Bar Size	Corrosion % to Cause Cracking
7	3.5/89	#4	4%
3	1.5/38	#4	1%

PREVENTION METHODS

- Keep concrete always dry, so that there is no H₂O to form rust. Also aggressive agents cannot easily diffuse into dry concrete. If concrete is always wet, then there is no oxygen to form rust.
- A polymeric coating is applied to the concrete member to keep out aggressive agents. A polymeric coating is applied to the reinforcing bars to protect them from moisture and aggressive agents. The embedded epoxy-coating on steel bars provide a certain degree of protection to the steel bars and, thereby, delay the initiation of corrosion. These coatings permit movement of moisture to the steel surface but restrict oxygen penetration such that a necessary reactant at cathodic sites is excluded.
- Hot-dipped galvanizing reinforcement
- Stainless steel or clad stainless steel is used in lieu of conventional black bars
- **FLY ASH : Using a Fly Ash concrete with very low permeability**, which will delay the arrival of carbonation and chlorides at the level of the steel reinforcement. Fly Ash is a finely divided silica rich powder that, in itself, gives no benefit when added to a concrete mixture, unless it can react with the calcium hydroxide formed in the first few days of hydration. Together they form a calcium silica hydrate (CSH) compound that over time effectively reduces concrete diffusivity to oxygen, carbon dioxide, water and chloride ions.
- A portion of the chloride ions diffusing through the concrete can be sequestered in the concrete by combining them with the tricalcium aluminate to form a calcium chloro-aluminate (Friedel's salt). It can have a significant effect in reducing the amount of available chlorides thereby reducing corrosion.
- **Electrochemical injection of the organic base corrosion inhibitors, ethanolamine and guanidine**, into carbonated concrete.
- The rougher the steel surface, the better it adheres to concrete. oxidation treatment (by water immersion and ozone exposure) of rebar increases the bond strength between steel and cement paste to a value higher than that attained by clean rebars. In addition, surface deformations on the rebar (such as ribs) enhance the bond due to mechanical interlocking between rebar and concrete.

- As the cement content of the concrete increases (for a fixed amount of chloride in the concrete), more chloride reacts to form solid phases, so reducing the amount in solution (and the risk of corrosion), and as the physical properties improve, the extent of carbonation declines, so preventing further liberation of chloride from the solid phase.
- **Electrochemical Chloride Extraction (ECE):** It is used in chloride contaminated concrete and the corrosion due to chloride ingress. In this process the chloride ions are transported out of the concrete by ion migration under the influence of an electric field.
- **Electrochemical realkalization:** This type of electrochemical treatment is majorly used to mitigate the carbonation induced corrosion. The aim of this treatment is to restore the alkalinity of carbonated concrete to prevent corrosion. The mechanism uses direct current to convey an alkaline solution into the concrete cover to increase the pH level of concrete.
- **Cathodic corrosion protection:** The principle involves applying a direct current in opposition to the corrosion current. This current polarizes the reinforcing steel in a way that any further corrosion of steel is mitigated.
- **Impressed current cathodic protection (ICCP) system:** This system starts with the installation of permanent anode i.e. activated titanium mesh, after which a direct current is provided in the structure via this permanent anode and external power supply.
- **Galvanic protection systems:** This metal relies on galvanic effect, i.e., using anodes made from metals/alloys like zinc or zinc-aluminium, which are prone to higher corrosion. The corrosion of the sacrificial metal generates an electric current that protects the reinforcing steel.

Fire Induced Structural Damages

The degree of damage caused depends upon the fire intensity, age of the structure, and duration for which the structure was under the attack of fire.

Behaviour of concrete under Fire

The effect of fire on concrete depends upon the higher temperature reached during the fire, length of fire period, the rate of temperature and properties of concrete. The resistance of concrete under fire depends upon type of cement, aggregate, w/c ratio, cement content, microstructure and thickness of cover to concrete. Concrete and masonry as a structural material is inherently superior in fire resistance in comparison to wood and steel. Concrete is a poor conductor of heat. Thermal conductivity reduces as temperature increases. Concrete is able to retain its strength for longer periods, even at a temperature of 700⁰C-800⁰C. Steel however, loses its strength at this high temperature.

Reduction in strength of concrete is absorbed as concrete reaches a temperature of 699⁰C. This reduction in strength is due to changes in the strength and deformability of the constituent materials of concrete, the changes in the c/s dimensions and weakening of the bond between the steel reinforcement and concrete. The aggregates in concrete except some limestone's and

sintered light-weight materials, contain minerals that are chemically bound with crystalline water inside concrete. The concrete, when exposed to heat from the fire, causes the boiling of this crystalline water. The resulting vapour pressure bursts the minerals and causes rapid and inwardly progressing spalling of the concrete. The loss of this chemically combined water is accompanied by a reduction in strength of concrete and changes in the chemical nature of the cement paste.

The changes that takes place in concrete properties at different peak temperatures is as follows:

- Upto 120⁰ C, i.e., oven drying temperature, there is no effect on microstructure or the pore system of concrete. Except for the loss of free moisture within the microstructure of concrete, no significant change in colour is noticed at this temperature.
- The exposure of 250⁰ C on concrete is characterized by localized cracks and dehydration of the cementitious paste with complete loss of free moisture accompanied by reduction in volume of the paste. This is the stage where the reduction in strength of cement paste gets commenced.
- Between 300⁰C-600⁰C, the colour of the concrete changes to pink. Significant cracking is observed in both cementitious paste and aggregate due to expansion.
- At temperatures greater than 400⁰C, the calcium hydroxide present in concrete starts getting decomposed.
- Complete dehydration of the cementitious paste along with considerable shrinkage cracking, honey combing is seen in the concrete exposed to the fire temperature greater than 600⁰C. Concrete at this temperature becomes friable, very porous and can be easily break down. The colour of the concrete at this temperature changes to grey. Apart from compressive strength, the flexure strength and modulus of elasticity of concrete also reduces under high temperature. This can be attributed to the micro-cracking that is formed in the transition zone of concrete due to fire.
- At the fire temperature greater than 900⁰C, colour of concrete changes to buff.
- Various components of concrete begin to melt at elevated temperature greater than 1200⁰C.
- The concrete melts completely at temperature greater than 1400⁰C

Type of distress seen in concrete structures under fire includes expansive spalling, strength reduction of concrete and steel, loss of anchorage of reinforcing steel, excessive steel, excessive deflection of slabs, beams and distortion of the whole structural framing.

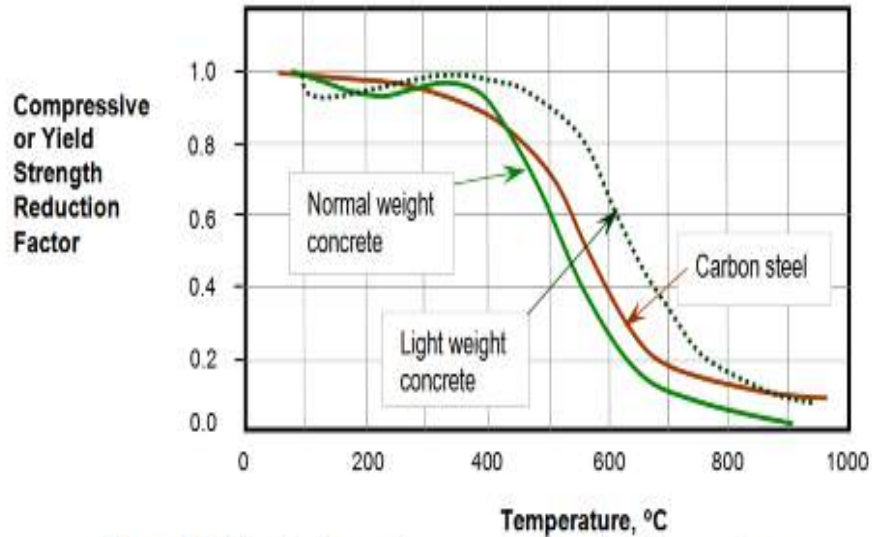

Figure 2.2. Reduction in concrete compressive strength with temperature (Astaneh-Asl et al. 2009)

Behaviour of steel under Fire

The excessive spalling of concrete, exposes the steel reinforcement to the heat, which causes it to soften as the temperature approaches 600°C. At this temperature, the bars lose about 50% of their yield strength which in turn reduces their capacity to resist the axial thermal restraining forces imposed by the surrounding construction. This causes the steel bars to buckle.

Fire-fighting operation post fire, results into quenching of the steel reinforcement in concrete. This results in loss of ductility that affects the load carrying capacity of the reinforced concrete members.



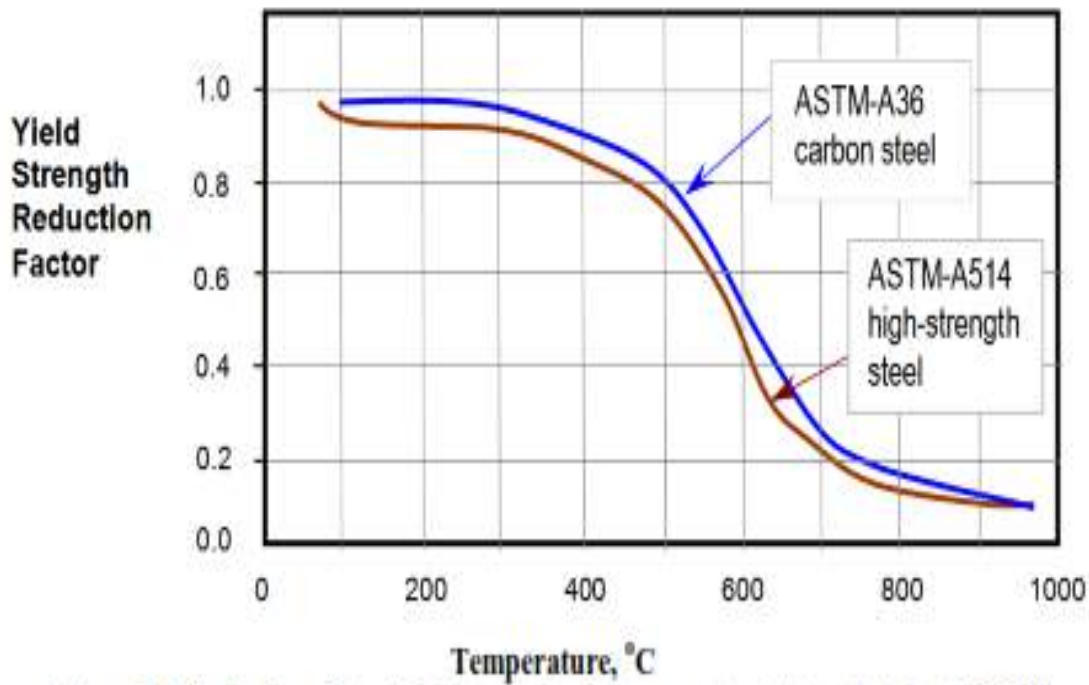

Figure 2.1. Reduction of steel yield strength with temperature (Astaneh-Asl et al. 2009)

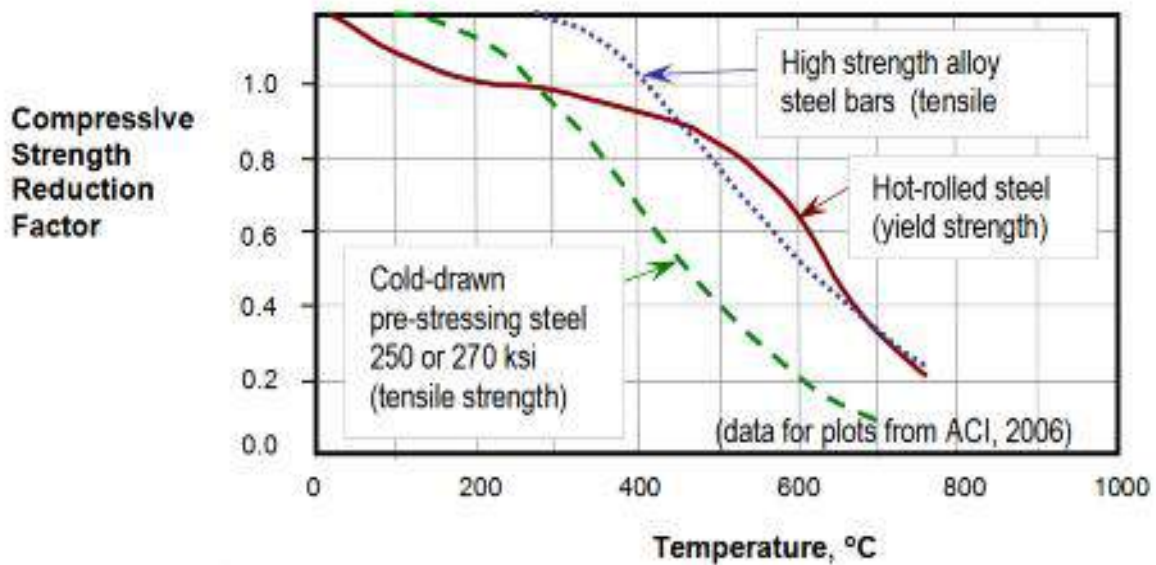

Figure 2.3. Reduction in strength of prestressing steel and high strength alloy bars with temperature (Astaneh-Asl et al. 2009)

Effects of steel weld

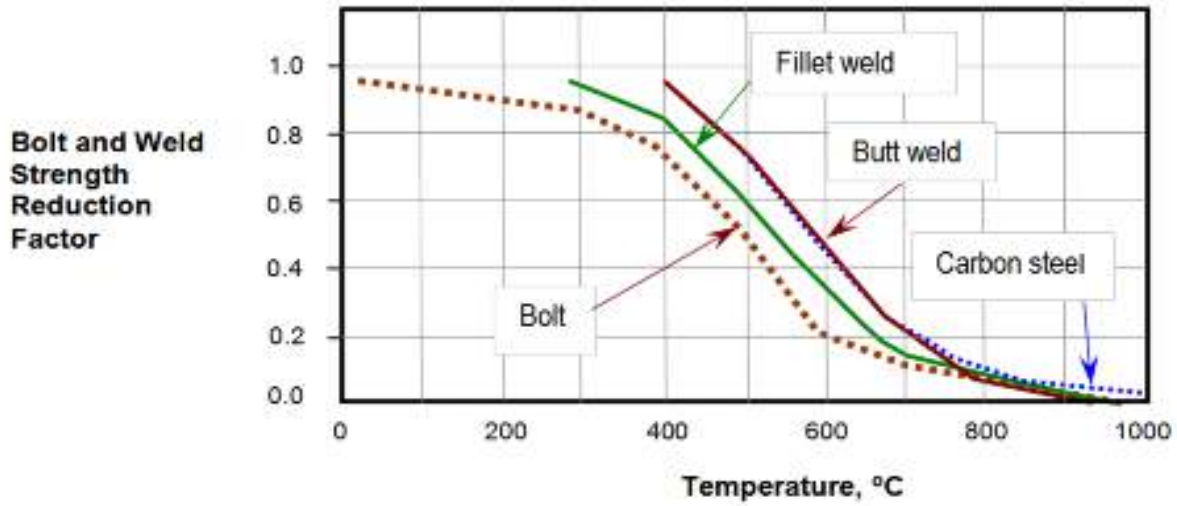
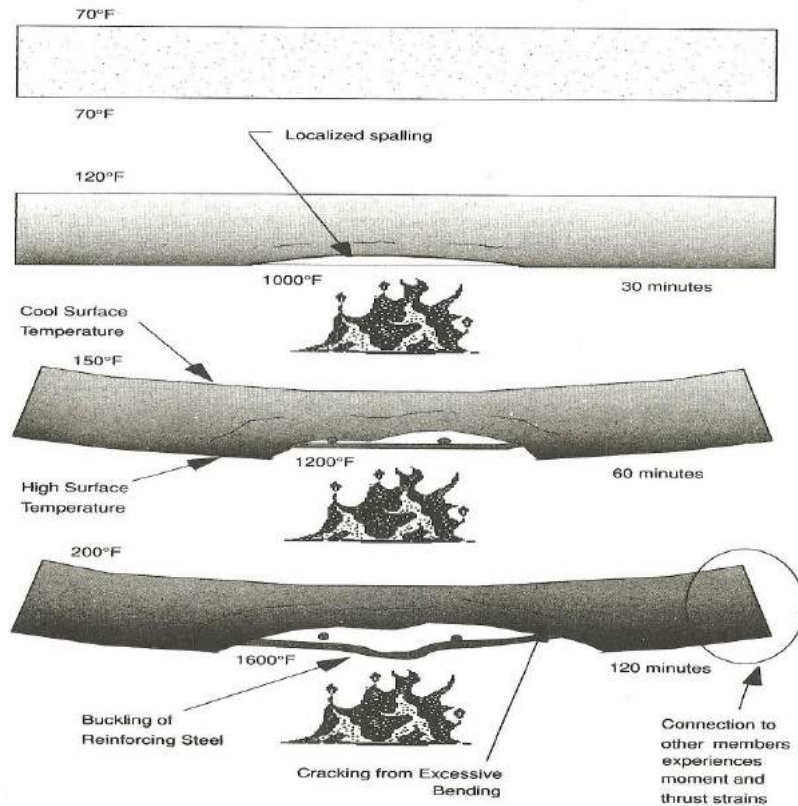

Figure 2.4. Reduction in strength of bolts, welds, reinforcing bars with temperature (Astaneh-Asl et al. 2009)



Example used from ACI Fire Endurance Tests 216R Fig 7.1.1 (b) Silica Aggregate 7" thick slab

Behavior of masonry under fire

The components of masonry, i.e., mortar and bricks are incombustible. However, they do get effected by the temperature of the flames, the duration for which the masonry is subjected to flames. The calcium carbonate in mortars gives off the carbon-di-oxide at temperature of 500⁰C and at about 900⁰C, it gets calcined, i.e. it gets transformed to quicklime, thereby losing most of its cohesive and adhesive properties. Bricks units of masonry will not be generally affected by the temperatures that are below the firing temperature. However, temperature more than the original firing temperature causes softening and distorting of bricks.

Assessment of Concrete Structures subjected to fire

Concrete structure subjected to fire must be assessed for the damage caused before any repair plan is carried out. The fire damage assessment begins with preliminary investigation followed by detailed investigation if required.

Preliminary Investigation

Visual Inspection: In this inspection observations related to cracking, spalling, deflections, distortions, misalignment and exposed steel reinforcement are measured and noted. The colour changes in concrete can be of considerable assistance in the assessment of damage owing to fire. The pink discoloration indicates concrete to have attained a temperature of 100⁰C-300⁰C accompanied by a significant loss of strength. If this pink discoloration extends to the reinforcement, i.e. beyond the cover thickness, further investigation on the strength of steel and concrete becomes imperative. Local buckling of steel bars bared by spalling in the flexural members is suggestive of its exposure to direct fire.

Determination of fire severity: In this phase of investigation, the debris found at the fire damaged site is examined in order to assess the severity of the fire incident. Examining of the debris helps to the estimate the maximum temperature that must have reached due to fire. Melting points of various materials helps in the investigation of severity of fire. For instance PVC used on cables, pipes, ducts, knobs, handles, house-ware etc. in case of fire at about temperature of 400⁰C-500⁰C get blackened or discolored due to partial burning. It fumes and emits vapour at 150⁰C.

A special note of presence of such materials during the investigation must be taken. PVC on burning will produce chlorine, which on combining with moisture from fire-fighting operation turns to hydrochloric acid. It becomes important to remove such substance before the acids migrate too far into the porous concrete and can attack the reinforcement causing corrosion.

Detailed investigation

A number of NDT testing such as ultrasonic pulse velocity (USPV), impact echo and impulse radar technologies are to be carried out. Destructive testing such as extraction of core samples or

steel reinforcement for existing concrete for laboratory testing is also done. USPV test results help to estimate the compressive strength, modulus of elasticity and quality of the hardened concrete. The impact-echo results help to detect, locate and classify discontinuities such as voids, delamination and loss of bond between cement paste and aggregates.

For assessing the extent of damage due to fire, it is essential to assess the penetration of heat by studying thermal gradient of the cores taken from the elements exposed directly to fire by investigating the colour changes of concrete along the depth of the core sample. peterographic analysis also help to analyze the loss of bond between the concrete and reinforcing steel, cracking in the interior of the member. The remaining strength of the reinforcement can be determined by carrying out the in-situ NDT tests such as hardness test on exposed portions of bars.

Laboratory tests such as differential thermal analysis (DTA), thermo gravimetric analysis (TG), X-ray Diffraction techniques are performed on the different number of samples taken from different location of fire damaged building. Samples at different depths are taken and analyzed and the sample from area directly exposed to fire is taken as reference.

The basic principle of TG analysis is to find the change in weight of material when exposed to increased temperature. The loss of weight gives an indication of the evaporation or decomposition of the material.

The principle on which DTA is based is that when material is slowly heated its temperature rises, but when the material undergoes any endothermic reaction i.e., losing water, CO₂, changes in crystalline structure or decomposition, its temperature remains constant. The advantage of DTA over TGA is that the changes not involving weight loss can also be detected.

In case of the concrete samples analyzed using differential thermal analysis, decomposition is indicated by the loss of Ca(OH)₂. The decomposition takes place due to the loss of water that results in the dehydration of Ca(OH)₂. The complete absence of Ca(OH)₂ in a sample taken from particular depth gives an indication that the concrete in that zone must have been exposed to temperature higher than 500⁰C.

Based upon the results & conclusions of the investigation, final evaluation must be made to determine whether the structural member should be left in their present condition or should be repaired, restored, replaced or demolished.

Repair of Fire Damaged Elements

The commonly used repair materials for damaged concrete structures are cementitious mortars, epoxy resin modified mortars or concrete.

The stages of repair strategy is as follows

- Removal of the unsound or damaged concrete
- Cleaning of reinforcing steel and installing new reinforcement, if required
- Cleaning of the exposed concrete surface
- Replace the removed concrete

Preparation of damage surfaces: Removal of the damaged concrete forms the most essential in fire damage. The affected concrete is to be removed because it would have lost all its strength and would thus interfere with development of structural bonds of any repair-mortar or concrete with sound concrete underneath. The removal of damaged concrete is carried out with the help of hand tools like hammer and chisel or light pneumatic tools. All the surrounding concrete & exposed steel after the removal of damaged concrete must be finally cleaned. The rust of the corroded bars can be removed by sandblasting device, hammers or wire brushing. Soot, smoke and other deposits should be removed by wet sandblasting or bush-hammering. Proper scaffolding must be kept ready for propping in case the removal causes any weakening of the structure.

Addition of new steel: New steel might be required to be added in case there is significant loss in the steel c/s. The bars which have been buckled also need replaced. In case of reparation of fire damaged structure, it is advisable to strengthen the temperature reinforcing steel, crack reinforcing steel and stirrups or binders to prevent cracking in the freshly placed concrete. This is to be done irrespective of the requirement of the strengthening of the main reinforcement.

Both new steel & concrete will be required, if there is a significant distortion in the beam or if the concrete is found to be damaged deeper than the reinforcement. New reinforcement in beams should be welded to the existing steel near the supports. New stirrups, if required, must be added and can be anchored with bolts or welding to existing stirrups. Usually the new stirrups are added by passing them through the holes cut in the slab so that the stirrups can be lapped or welded.

In case of columns, if the longitudinal bars have buckled and the lateral displacement is found to be larger, then the buckled bars need to be fastened with new links. This might also require enlarging the section of the column to provide sufficient cover to the new links. The new steel in the damaged column due to fire may be anchored to the beam reinforcement or may be passed through the holes in slab to provide the vertical continuity of steel.

Replacement of concrete:

Three methods to replace concrete are: recasting in formwork, spraying or shotcrete and hand-applied mortars. Spraying and recasting are most suitable in large area applications. Concrete should be thoroughly wetted and kept damp for several hours. In case of sprayed concrete, all the coatings must be removed so as to develop a strong bond between the existing and the sprayed concrete. It is generally advisable to use steel mesh all over the area that needs to be shotcreted.

The provision of steel mesh helps to develop a proper bond between the existing and sprayed concrete and also minimizes the risks of cracks.

Replacement of concrete in columns or in beams by shotcreting or recasting depends upon certain factors such as the thickness required in the new concrete and the requirement of a high standard of surface finish. Shotcreting enables the thinner layers of concrete to be placed without increasing the dimensions of concrete. It also produces dense concrete and no compaction is required after repair. Recasting is the preferred method of replacing the removed concrete, if a high standard of surface finish is the requirement and an increase in c/s of column is permitted.

For patch repairs and repair of less volume, the hand applied mortars or resin based repair materials are used. In case of the structures exposed to fire for only a brief time, may cause the surface to be crazed. The crazing cracks being too shallow do not affect the strength, however they mar the appearance of the surface. Painting such surfaces with a good grade of latex paint or painting with Portland cement based paint that contains powdered latex can help to restore the original finish.

What is Fire Rating?

Fire resistance can be defined as the ability of structural elements to withstand fire or to give protection from it (2). This includes the ability to confine a fire or to continue to perform a given structural function, or both. Fire Resistance Rating (or fire rating), is defined as the duration of time that an assembly (roof, floor, beam, wall, or column) can endure a “standard fire” as defined in ASTM E 119.

The effect of fire on the resistance of a simply supported reinforced concrete slab is shown in figure. If the bottom side of the slab is subjected to fire, the strength of the concrete and the reinforcing steel will decrease as the temperature increase. However, it can take up to three hours for the heat to penetrate through the concrete cover to the steel reinforcement. As the strength of the steel reinforcement decreases, the moment capacity of the slab decreases. When the moment capacity of the slab is reduced to the magnitude of the moment caused by the applied load, flexural collapse will occur. It is important to point out that duration of fire until the reinforcing steel reaches the critical strength depends on the protection to the reinforcement provided by the concrete cover.

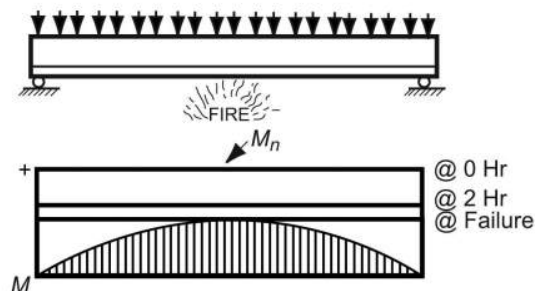

ASTM E119 Standard Fire Test

The fire-resistive properties of building components and structural assemblies are determined by fire test methods. The most widely used and nationally accepted test procedure is that developed by the American Society of Testing and Materials (ASTM). It is designated as ASTM E 119, Standard Methods of Fire Tests of Building Construction and Materials. A standard fire test is conducted by placing a full size assembly in a test furnace. Floor and roof specimens are exposed to a controlled fire from beneath, beams are exposed from the bottom and sides, walls from one side, and columns are exposed to fire from all sides. The temperature is raised in the furnace over a given period of time in accordance with ASTM E 119 standard time-temperature curve shown in Figure 6. This specified time-temperature relationship provides for a furnace temperature of 1000° F at five minutes from the beginning of the test, 1300° F at 10 minutes, 1700° F at one hour, 1850° F at two hours, and 2000° F at four hours. The end of the test is reached and the fire endurance of the specimen is established when any one of the following conditions first occurs:

1. For walls, floors, and roof assemblies, the temperature of the unexposed surface rises an average of 150° F above its initial temperature of 325° F at any location. In addition, walls achieving a rating classification of one hour or greater must withstand the impact, erosion and cooling effects of a hose steam test.
2. Cotton waste placed on the unexposed side of a wall, floor, or roof system is ignited through cracks or fissures which develop in the specimen during the test.
3. The test assembly fails to sustain the applied service load.
4. For certain restrained and all unrestrained floors, roofs and beams, the reinforcing steel temperature rises to 1100° F.

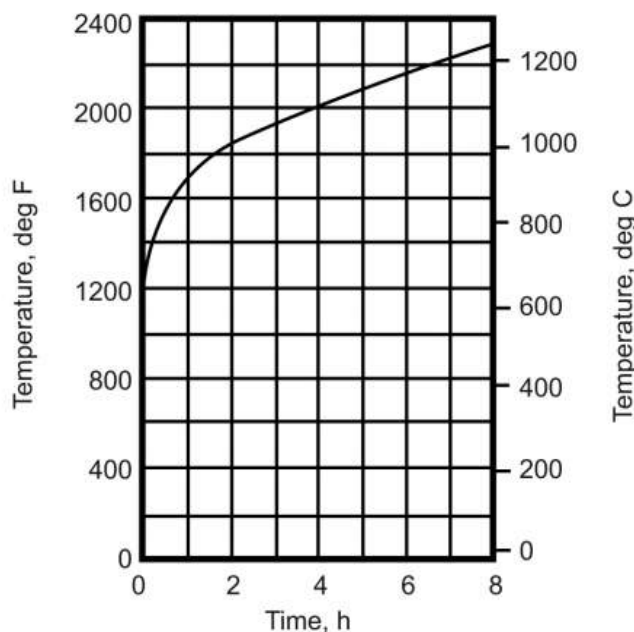

Experience shows that concrete floor/roof assemblies and walls usually fail by heat transmission and columns and beams by failure to sustain the applied loads, or by beam reinforcement failing to meet the temperature criterion.

Thickness Requirements

Test results show that fire resistance in concrete structures will vary in relation to the type of aggregate used. Table 1 shows a summary of the minimum thickness requirements for floor slabs and cast in place walls for different concrete types and for different fire resistance ratings. Table 2 summarizes the minimum column dimensions for different concrete types and different fire resistance ratings. Tables 1 and 2, show that there may be economic benefits to be gained from the selection of the type of concrete to be used in construction. The designer is encouraged to evaluate use of the alternative materials.

Table 1 Minimum thickness for cast in place floor and roof slabs, in.

Concrete type	Fire resistance rating				
	1 hr.	1.5 hr.	2 hr.	3 hr	4 hr.
Siliceous aggregate	3.5	4.3	5.0	6.2	7.0
Carbonate aggregate	3.2	4.0	4.6	5.7	6.6
Sand-lightweight	2.7	3.3	3.8	4.6	5.4
Lightweight	2.5	3.1	3.6	4.4	5.1

Table 2 Minimum concrete column dimensions, in.

Concrete type	Fire resistance rating				
	1 hr.	1.5 hr.	2 hr.	3 hr	4 hr.
Siliceous aggregate	8	9	10	12	14
Carbonate aggregate	8	9	10	11	12
Sand-lightweight	8	8.5	9	10.5	12

Cover Requirements

Another factor to be considered in complying with fire-resistive requirements is the minimum thickness of concrete cover for the reinforcement. The concrete protection specified in ACI 318 for cast-in-place concrete will generally equal or exceed the ACI 216.1 minimum cover requirements, but there are a few exceptions at the higher fire ratings. The minimum concrete cover to the positive moment reinforcement is given in Table 3 for one-way or two-way slabs with flat undersurfaces. The minimum concrete cover to the positive moment reinforcement (bottom steel) in reinforced concrete beams is shown in Table 4.

Table 3 Minimum cover for floor and roof slabs, in.

Concrete type	Fire resistance rating					
	Unrestrained					Restrained
	1 hr.	1.5 hr.	2 hr.	3 hr	4 hr.	4 hr. or less
Siliceous aggregate	0.75	0.75	1	1.25	1.625	0.75
Carbonate aggregate	0.75	0.75	0.75	1.25	1.25	0.75
Sand-lightweight	0.75	0.75	0.75	1.25	1.25	0.75

Table 4 Minimum cover requirements to main reinforcement in beams (All types), in.

Restrained or unrestrained	Beam width, in.	Fire resistance rating				
		1 hr.	1.5 hr.	2 hr.	3 hr	4 hr.
Restrained	5	0.75	0.75	0.75	1	1.25
	7	0.75	0.75	0.75	0.75	0.75
	≥ 10	0.75	0.75	0.75	0.75	0.75
Unrestrained	5	0.75	1	1.25	-	
	7	0.75	0.75	0.75	1.75	3
	≥ 10	0.75	0.75	0.75	1	1.75

* Minimum cover for reinforcement in columns, for all aggregate types, is the smaller of, 1 in. times the number of hours of required fire resistance, or 2 in. (Reference 1)

Desiccation: Desiccation is a phenomenon referring to dryness of the material induced by the loss of moisture. Self-desiccation, or internal drying, is a phenomenon caused by the chemical reaction of cement with water. The reaction leads to a net reduction in the total volume of water and solid. Consequently, an air-space is formed inside concrete that is protected from water ingress.

Self-desiccation occurs in all concrete irrespectively of the water-cement ratio. However, its effects are very different in different types of concrete. In normal concrete, with water-cement ratio above about 0.45 to 0.50, self-desiccation often occurs unnoticed. The recent trend in concrete technology towards so-called high-performance, or low water-cement ratio (w/c), concretes has not been without its problems. One of the major observed problems with these mixtures is their increased tendency to undergo early-age cracking. While this cracking may or may not compromise the (higher) compressive strengths of these concretes, it likely does compromise their longterm performance. The phenomenon of early-age cracking is complex and depends on thermal effects, autogenous strains and stresses, drying, stress relaxation, and structural detailing and execution. In concretes with low w/c, a major contributor to early age cracking can be the autogenous shrinkage induced by the self-desiccation that occurs during hydration under sealed or partially saturated conditions. As the cementitious materials hydrate under sealed conditions, empty porosity is created within the ‘set’ microstructure, because the

hydration products occupy less volume than the starting materials. The water menisci created by these empty pores in turn induce autogenous shrinkage stresses on the three-dimensional microstructure. The main reason is that it causes a reduction in the internal relative humidity (RH) of the concrete. A reduced RH-level, and reduced saturation level, can be maintained for long time also when the concrete is stored in water. Thus, self-desiccation has both negative and positive effects; e.g., (i) the reduced RH gives rise to drying shrinkage which will add to normal drying shrinkage, but which takes place earlier than this, and which may give internal micro-cracking, (ii) the self-desiccation shrinkage adds to thermal shrinkage caused by hydration, thus increasing the risk of early (macro-) cracking, (iii) the reduced RH radically shortens the required drying time before concrete can be covered by moisture and alkali sensitive materials, (iv) the reduced saturation level increases the resistance to internal frost damage, especially when the concrete is young.

Advantages of self-desiccation

Since saturated conditions are a condition for chlorides to be transported the ingress of chlorides may be stopped more or less at low w/c where self-desiccation occurs.

Preventive Measures:

Self desiccation which is the driving force for autogenous shrinkage cannot be eliminated by traditional curing methods. The novel approach, that has been recently proposed, is autogenous (internal) curing. It suggests incorporating pre-soaked lightweight aggregate into the mix, which will act as internal water reservoir, preventing reduction in relative humidity. This method is frequently named “autogenous curing”. Previous experimental work demonstrated that autogenous curing can be successfully applied to obtain improved high strength concrete with reduced sensitivity to cracking. However, the lightweight aggregate content required to eliminate autogenous shrinkage was high, which resulted in reduced compressive strength and increase in the price of the concrete.

- Use of shrinkage-reducing admixture (SRA),
- increasing the internal water supply via the replacement of sand by saturated low-density fine aggregates

Addition of superabsorbent polymer particles (SAP), and using a coarser silica fume.

TOPIC 3: REPAIRS, SUBSTRATE PREPARATION & MAINTENANCE

Need for Evaluation of Reinforced Concrete Structures

The different types of deterioration get noticed in different forms like cracking, spalling, staining etc. These visual forms indicate the presence of problem. The symptoms alone are not enough to find the correct solution, the reason being there could be more than one cause responsible for the particular symptom.

It is imperative to determine and eliminate the cause of the original damage because any repair that is made on the basis of an incorrect estimation of the cause is likely to damage the repaired concrete also, resulting in larger and expansive repair of repairs.

Condition Evaluation of Reinforced Concrete Structures

Condition evaluation is generally carried out under any of the given circumstances

- Change in resistance of structure due to deterioration owing to time-dependent processes such as corrosion or fatigue
- Structural damage due to accidental loadings like earthquake, tsunami, fire, blasts, etc.
- Structures subjected to change in use, operational changes or increased load where it is necessary to check the adequacy of the structure to resist additional loads.

Condition assessment generally leads to two major findings

- Condition of the structure is satisfactory and requires no further intervention
- Structures require any of the following
 - **Preservation:** The process of maintaining a structure in its present condition and arresting further deterioration
 - **Rehabilitation:** The process of repairing or modifying the structure to its desired useful condition.
 - **Repair:** The process of replacing or correcting deteriorated, damaged, or faulty materials, components, or elements of a structure.
 - **Restoration:** the process of re-establishing the materials, form, and appearance of the structure.
 - **Strengthening:** The process of increasing the load-resistance capacity of a structure or portion.
 - **Retrofitting:** the process of strengthening the structure along with structural system.

Condition assessment of the structure is the systematic and logical examination of the structure to identify the area and cause of distress.

The objectives of condition assessment include the following:

- To provide insight into the current condition of the structure i.e. to identify the cause & source of observed distress.
- To assess the extent and development of the deterioration
- To assess the influence of the deterioration on the safety and life expectancy of the structure i.e. determining the residual strength of structure and its possibility of being repaired.
- To accurately assess the scenario of concrete in structure in terms of its physical, chemical and electro-chemical properties.
- To prioritise the repair of the distressed elements in order of the seriousness of the deterioration.
- To chart out an effective and economically feasible concrete-repair program.

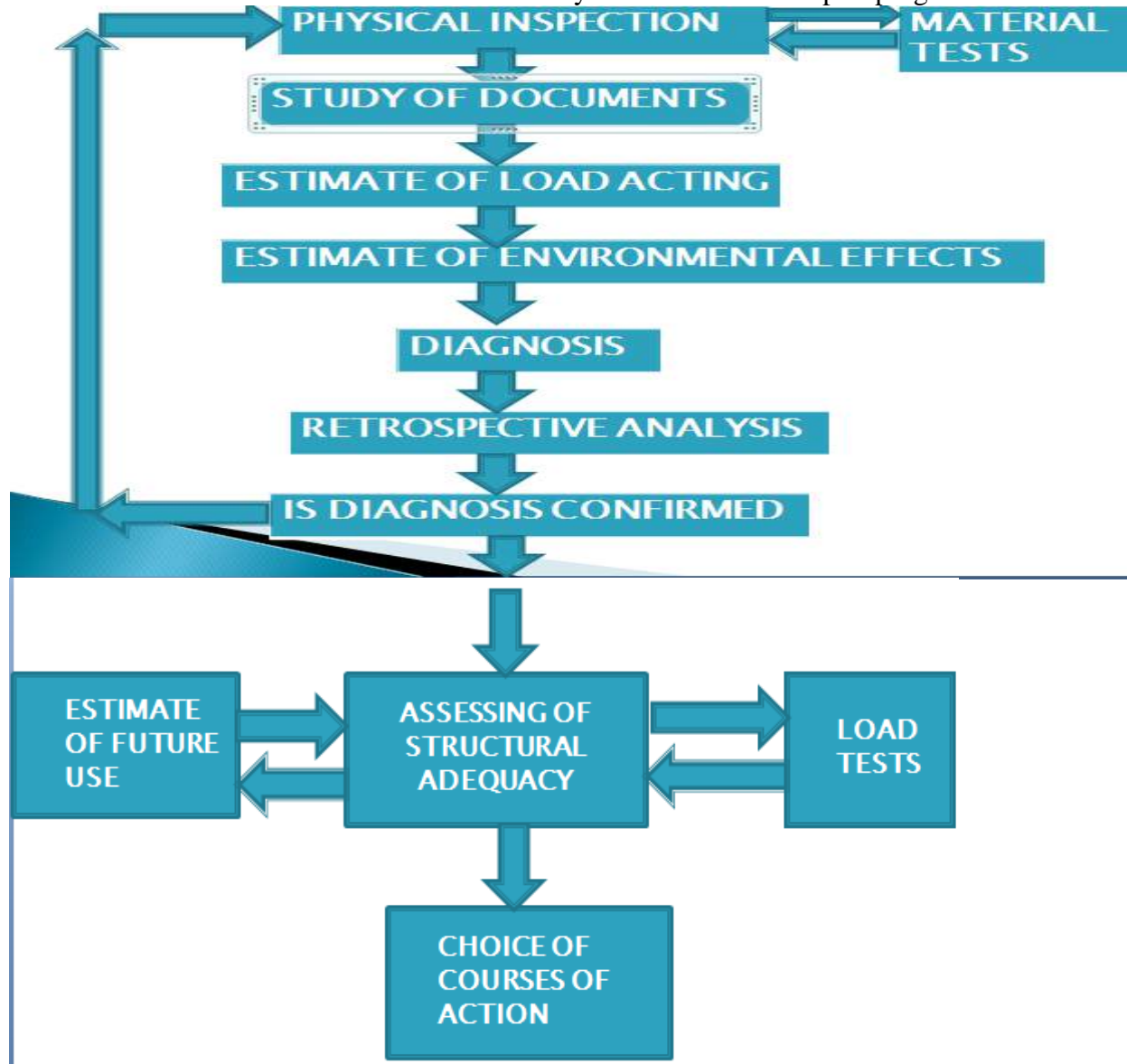

Stages of conditional Assessment

- Preliminary investigation
- Detailed investigation

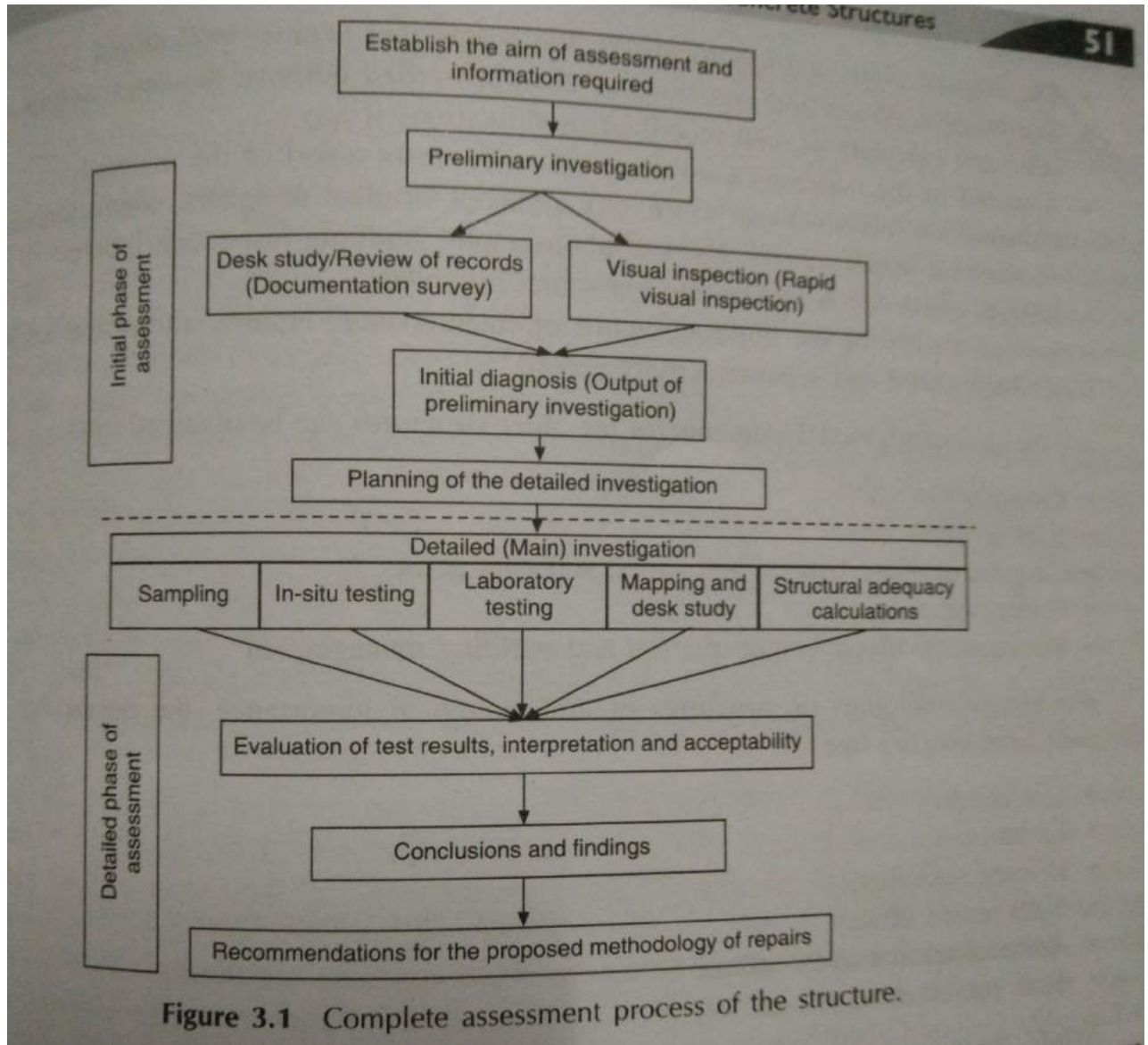

Preliminary investigation: It helps to understand the past record of the structure in terms of the distresses and repair carried out if any. It is also helps to assess the apparent physical condition, robustness, structural integrity and strength of structure.

The main objective of preliminary investigation include

1. To obtain the initial information regarding the condition of structure by studying past records based on the information obtained from the owners, occupants of the buildings and general public.
2. To get an overview of the existing state of the structure to obtain a reliable assessment of the available structural capacity.
3. To understand the type and the seriousness of the problems affecting the structure
4. To determine the feasibility of performing the required repairs and rehabilitation works.
5. To identify the need for detailed investigation
6. To plan the necessary site preparations, procurement of the required field-testing equipment and tools for sampling.

Preliminary investigation can be broadly classified into two headings: Review of records, Condition survey.

Review of record: A thorough review of all pertinent data related to design, construction and service life of the structure is assessed in evaluating the condition of structure. The list of records which should be gathered includes:

- The original plans & specifications
- The original design and construction documents like design, drawings, specifications, structural calculations, and record of modification if any
- A record of materials used in construction-tests reports of the material
- Building inspection records
- Design construction and testing personnel involved
- Service history of building-record of maintenance, repairs, alterations, settlement, weather record and seismic-activity record.

Condition survey: condition survey is a qualitative and systematic inspection that forms the key step for making the correct evaluation of the distressed structure. In simple words, it is rapid visual inspection of the structure which provides a fair idea about the signs of distress and deterioration, the structural and non-structural deficiencies, irregularities in building configuration and construction defects.

The condition survey when carried out as a part of preliminary investigation is just a rapid visual inspection. Limited non-destructive and destructive testing techniques can sometimes be used to confirm the measurements and observations made during the condition survey. This can include non-destructive physical testing such as visual inspection to find cracks and staining, localization of voids, measurement of the concrete cover around the reinforcement, measuring the size of cracks, estimate the widths and length of the cracks, to determine the movement the movement in cracks, i.e. if the cracks are active or passive, to record the located cracks on structural plan or grid sheet.

Sometimes in order to locate very fine cracks, the concrete is wetted and allowed to dry. The water thus trapped in the fine cracks, will make the very fine cracks, will make the very fine cracks to appear as dark lines. Movement in the cracks can be monitored by using tell-tale i.e., by using glued glass strips, or by conventional method such as wedging a pin or toothpick into the cracks or taping a piece of notched tape or butter paper across the crack. Extension of the crack causes the pin to loosen and move in the former case and in latter case the tape tears if the crack widens, and tape wrinkles, when the crack moves.

Sometimes destructive physical testing carried out by taking out core sample from the concrete surface to determine the mechanical characteristics of concrete or dust samples taken to estimate the chloride ion content. This type of preliminary non-destructive testing can help to identify locations within a structure that requires more detailed & extensive non-destructive or destructive testing.

Things one must look for while carrying out the visual inspection

1. Verification of information collected during desk study, i.e., to verify if the on-site conditions are in conformance to the available designs and drawings.
2. Structural framing
3. Record of the existing condition of concrete, i.e., note of construction faults like bug holes, cold joints, honey combing, exposed reinforcement, corrosion etc.
4. Presence of cracking (location, depth, width, nature of cracking, the surface appearance of the cracks, current state of activity, physical state of concrete when the cracking occurred)
5. Surface appearance of cracks (pattern of cracks, length of cracks, short cracks or interconnected)
6. The surface appearance of concrete (texture, discolouration, staining, spalling, delamination and erosion)
7. Sources of leakage or seepage due to concealed services, through joints or cracks, inadequate systems of rain water disposal, improper terrace slope or absence of rain water pipes, ponding of water and discolouration due to dampness must be noted.
8. Movements of structures in the form of excessive deflections, heaving or settlement.
9. Damage to structural elements & finishes like blistering membranes and coatings.

Rapid Visual Inspection (RVI): RVI is carried out to make a thorough and an accurate inspection of the building. This kind of inspection is carried out in any of the following situations:

1. To carry out the periodic structural inspection of the buildings.
2. To have a quick inspection of the structure to determine, if it is unsafe for the inhabitants in case of severe damage due to fire or natural calamity.

Overall building assessment: In overall building assessment, the inspector must look for any abnormal deformation or deflection. Check for any leaning of the building, soil displacement under foundations, load bearing wall or settlement of the floor. Water leakage, ponding areas, areas of poor drainage or other indications of water problems must be noted. Evidence of any type of chemical deterioration on the building must also be noted.

Component assessment: The inspector needs to focus on specific building elements for presence of any kind of defects or deterioration. The component assessment has to be properly documented along with sketches showing particular distressed structural member, location, classification and extent of distress, besides the photographic record of defects like cracks, spalls and other surface defects, honey combing, corrosion of reinforcement, loss of c/s, deflections and other misalignments.

TABLE 3.1 Format for Rapid Visual Inspection (RVI) of the Buildings

Sr. No.	Description	Details
PART 1 GENERAL INFORMATION OF THE BUILDING		
1	Name and address of the building, Year of the construction	

56 Repair and Rehabilitation of Concrete Structures

2	TYPE OF BUILDINGS Load bearing/partially load bearing and partly RCC/RCC frame		
3	Number of storey in each block of the building		
4	Description of the main usage of the building: Residential/educational/office/ hostel/ workshop/hospital/any other specify		
5	TYPE OF FLOOR and ROOF RCC/Wooden/Steel		
6	Year of construction. Maintenance history of the building if known to be mentioned		
PART 2 STRUCTURAL SYSTEM OF THE BUILDING			
1	Description of the structural forms, systems and materials used in different parts of the building, e.g., RCC, prestressed concrete, steel, etc.		
2	Description of soil condition and foundation system, if known		
3	Identification of critical structures (e.g. slender columns, floating columns, cantilever structures, long span structures, etc.)		
4	Description of any area not covered in visual inspections. State the reasons for the same.		
5	State, if the existing usage and loading condition is compatible with the intended purpose of structure		
6	State the misuse, abuse or deviation has given rise to excessive loading		
7	State, if there was any addition/alteration works done to the building structure		
PART 3 SURVEY OF SIGNS OF DISTRESS, DEFORMATION OR DETERIORATION IN BUILDING STRUCTURE (CONDITION ASSESSMENT)			
1	LEANING OF BUILDING	YES <input type="checkbox"/>	NO <input type="checkbox"/>
2	SETTLEMENTS (a) Floor settlement (b) Settlement of load bearing wall (c) Settlement of RCC foundation	<input type="checkbox"/> <input type="checkbox"/> <input type="checkbox"/>	<input type="checkbox"/> <input type="checkbox"/> <input type="checkbox"/>

3		DEFECTS (Extent of defect)				
		Insignificant	Slight	Moderate	Severe	Very severe
A	Cracking	<input type="checkbox"/>	<input type="checkbox"/>	<input type="checkbox"/>	<input type="checkbox"/>	<input type="checkbox"/>
	Plastic shrinkage/settlement	<input type="checkbox"/>	<input type="checkbox"/>	<input type="checkbox"/>	<input type="checkbox"/>	<input type="checkbox"/>
	Thermal cracking	<input type="checkbox"/>	<input type="checkbox"/>	<input type="checkbox"/>	<input type="checkbox"/>	<input type="checkbox"/>
	Structural	<input type="checkbox"/>	<input type="checkbox"/>	<input type="checkbox"/>	<input type="checkbox"/>	<input type="checkbox"/>
	Crazing	<input type="checkbox"/>	<input type="checkbox"/>	<input type="checkbox"/>	<input type="checkbox"/>	<input type="checkbox"/>
	Honey combing	<input type="checkbox"/>	<input type="checkbox"/>	<input type="checkbox"/>	<input type="checkbox"/>	<input type="checkbox"/>
	Cracking in load bearing walls	<input type="checkbox"/>	<input type="checkbox"/>	<input type="checkbox"/>	<input type="checkbox"/>	<input type="checkbox"/>
	Cracking in RCC component (Attach separate sheets for crack details, if required)	<input type="checkbox"/>	<input type="checkbox"/>	<input type="checkbox"/>	<input type="checkbox"/>	<input type="checkbox"/>
B	Water seepage	<input type="checkbox"/>	<input type="checkbox"/>	<input type="checkbox"/>	<input type="checkbox"/>	<input type="checkbox"/>
	Pop-outs	<input type="checkbox"/>	<input type="checkbox"/>	<input type="checkbox"/>	<input type="checkbox"/>	<input type="checkbox"/>
	Spalling	<input type="checkbox"/>	<input type="checkbox"/>	<input type="checkbox"/>	<input type="checkbox"/>	<input type="checkbox"/>
	Rust staining	<input type="checkbox"/>	<input type="checkbox"/>	<input type="checkbox"/>	<input type="checkbox"/>	<input type="checkbox"/>
C	Extent of corrosion	<input type="checkbox"/>	<input type="checkbox"/>	<input type="checkbox"/>	<input type="checkbox"/>	<input type="checkbox"/>
	(a) Corrosion in longitudinal bars	<input type="checkbox"/>	<input type="checkbox"/>	<input type="checkbox"/>	<input type="checkbox"/>	<input type="checkbox"/>
	(b) Corrosion in lateral ties/rings	<input type="checkbox"/>	<input type="checkbox"/>	<input type="checkbox"/>	<input type="checkbox"/>	<input type="checkbox"/>
	(c) Debonding of surface due to corrosion	<input type="checkbox"/>	<input type="checkbox"/>	<input type="checkbox"/>	<input type="checkbox"/>	<input type="checkbox"/>
	(d) Deflection in beams/slabs (Attach separate sheets for details preferably with photographs)	<input type="checkbox"/>	<input type="checkbox"/>	<input type="checkbox"/>	<input type="checkbox"/>	<input type="checkbox"/>
4	State of the existing repairs (if any carried out in structure)	<input type="checkbox"/>	<input type="checkbox"/>	<input type="checkbox"/>	<input type="checkbox"/>	<input type="checkbox"/>
	(a) Delamination/debonding	<input type="checkbox"/>	<input type="checkbox"/>	<input type="checkbox"/>	<input type="checkbox"/>	<input type="checkbox"/>
	(b) Cracking Others (specify)	<input type="checkbox"/>	<input type="checkbox"/>	<input type="checkbox"/>	<input type="checkbox"/>	<input type="checkbox"/>
5	OVERALL STRUCTURAL CONDITION ASSESSMENT (Based on initial design and construction and present structural condition assessments)	Unsafe			<input type="checkbox"/>	
		Potentially hazardous			<input type="checkbox"/>	
		Severe			<input type="checkbox"/>	
		Moderate			<input type="checkbox"/>	
		Minor			<input type="checkbox"/>	
		Good condition			<input type="checkbox"/>	
6	RECOMMENDATIONS					
	(a) No further action required					
	(b) Repair/strengthening works necessary					
	(c) Detailed assessment required					
	(d) Barricade/non-use needed					
	(e) Reconstruction or any other suggestions					

Output of preliminary Investigation

The major inferences that can be drawn after the preliminary investigation include the following:

1. Description of the actual condition of the existing structure including the location, extent and nature of the deterioration or distress.

2. A quality classification of the components or the whole structure and the repair/rehabilitation option based on condition and degree of damage.
3. Is there any need for detailed investigation

Damage classification based on preliminary investigation

This damage classification is based upon the findings of visual inspection

Rating	Damage classification	Description	Repair strategy
1	Cosmetic	No structural distress except for insignificant crazing or spalling of plaster or finishes	Redecoration
2	Superficial surface damage	Surface finishes locally damaged. Local spalling of concrete without reinforcement being exposed. No structural cracks observed	Superficial Repairs
3	Structural surface damage	Finishes totally damaged, moderate spalling with partly exposed rfm, minor structural cracks observed, bond b/w concrete & steel rfm intact	Minor structural repairs
4	Structural damage to c/s	Spalling of concrete all around the member with the major part of rfm exposed, major structural cracks, bond b/w rfm & concrete locally destroyed due to corrosion leading to reduction in load carrying capacity, minor distortion noticeable	Principal Repairs
5	Structural damage to member	Excessive spalling resulting in a major reduction of c/s, almost all rfm exposed, extensive cracking along rfm indicating the bond failure b/w concrete & rfm noticeable deformation or distortion, major structural loss necessitating replacement of members	Major repair/ Demolition and recasting

Cosmetic repairs: Such repairs are carried out only to restore the initial appearance of the structure.

Structural repairs: The minor, principal and major structural repairs fall under this category. During these repairs, the distressed sections are either repaired or replaced to restore the structural integrity of the section. Such repairs reduce or eliminate the cause of deterioration.

Replacement/recasting/demolition: Such repair practice is resorted to when the assessed damage levels are found to be extensive which lead to expansive repairs.

Detailed Investigation:

The detailed investigation is required to be conducted when the pertinent data like the original construction drawings and design of the structure, foundation details and structural details are not available. It is also required when the information furnished by the preliminary investigation is not conclusive and further investigation is required to design a repair/retrofitting works. The detailed investigation may not necessarily be done to document the condition of the whole building, but only the elements subjected to investigation in detail based on recommendations of preliminary investigation.

Scope and methodology of detailed investigation

1. Procure complete documentation of information related to design, construction, maintenance and the history of the building.
2. Assess the structural adequacy by checking the structural plans and calculations and verifying the same by measuring the dimensions of the elements of the existing building on site.
3. Carry out the tests on the materials used like concrete, steel and masonry with the help of destructive, semi-destructive and non-destructive test methods in the field and also laboratory investigation of the samples collected from the field.
4. Conduct all the necessary geotechnical investigations to collect data of the soil profile and its characterization.
5. Carry out load tests on parts of the building, if necessary.

The detailed investigation, generally involves a wide range and types of sampling and testing. The selection of the testing methods however depends upon the type, extent of deterioration and the importance of the structure. The use of various testing methods like destructive tests, semi-destructive becomes necessary at the stage of detailed investigation. These tests are required to be conducted to determine typical parameters like:

- Verification/identification of current geometry/member size
- Estimation of the in-situ compressive strength of concrete
- Detection of hidden flaws and defects, presence of cracks, voids and other imperfections
- Location and spacing of embedded items like reinforcement profile, measure of cover and bar diameter, etc.
- Assessing the extent of damage, i.e., corrosion, chemical attack (chlorides, sulphate, alkali content) and degree of carbonation
- Determining the material properties, i.e., concrete and reinforcing steel properties
- Mapping of the cracks
- Installation of instruments to monitor the changes in structure of concrete over time, movement of cracks.

In-situ and Laboratory Testing of Concrete

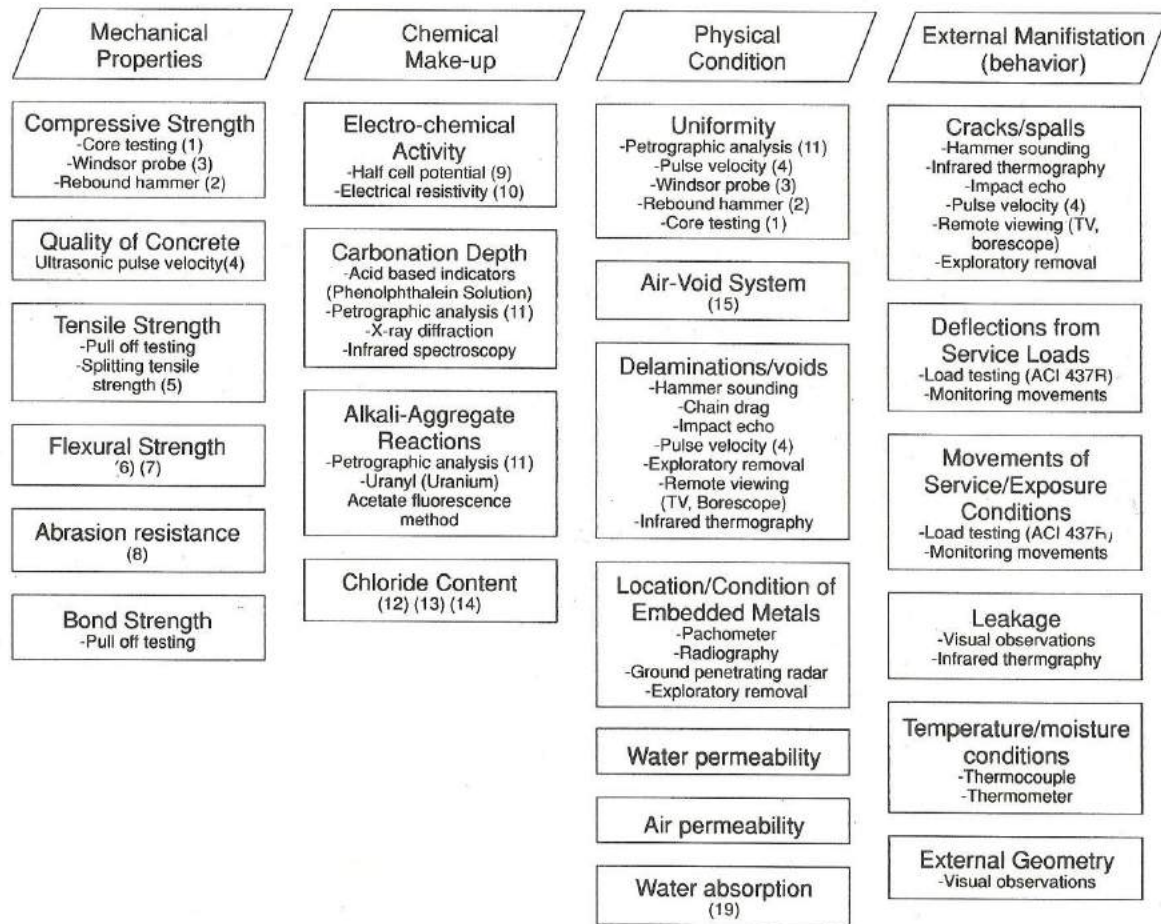

Testing For Mechanical Properties

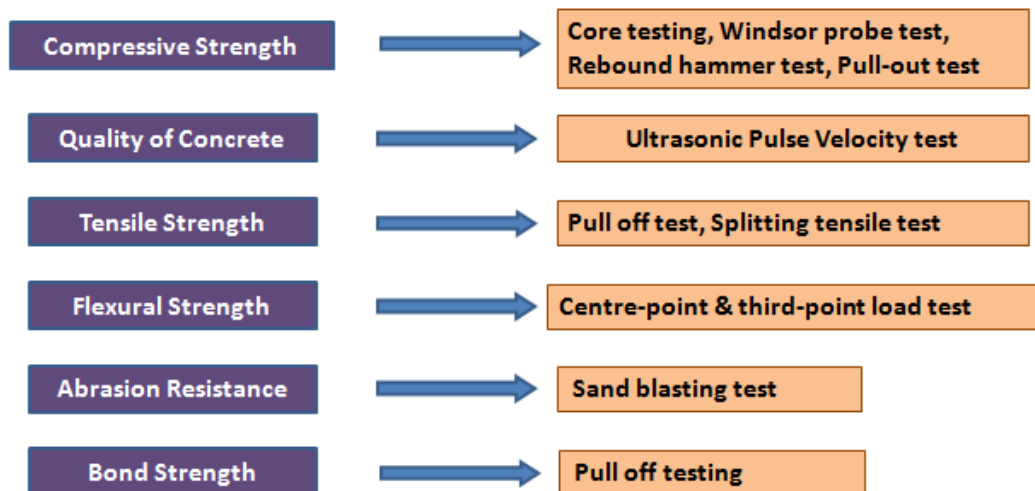

Visual tactile/Sounding method

This method involves sounding which is simple and effective method to locate delamination. When striking the areas of delamination the sound of the hammer changes from solid sound (“ping”) to a hollow sound (“pluck”). Steel chain is dragged in case of slabs, whereas hammer is used for small areas.

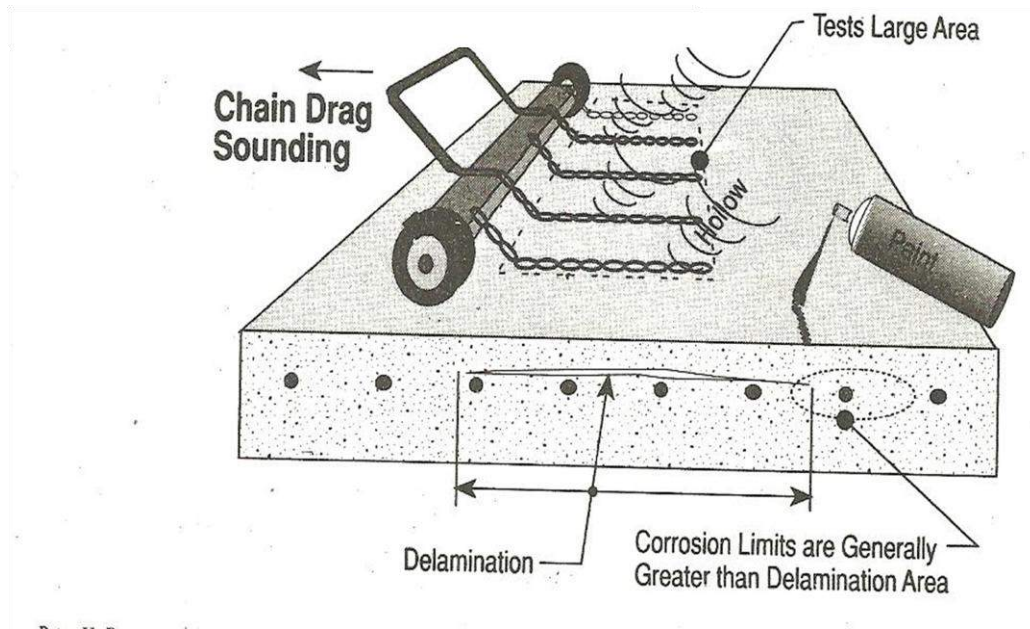
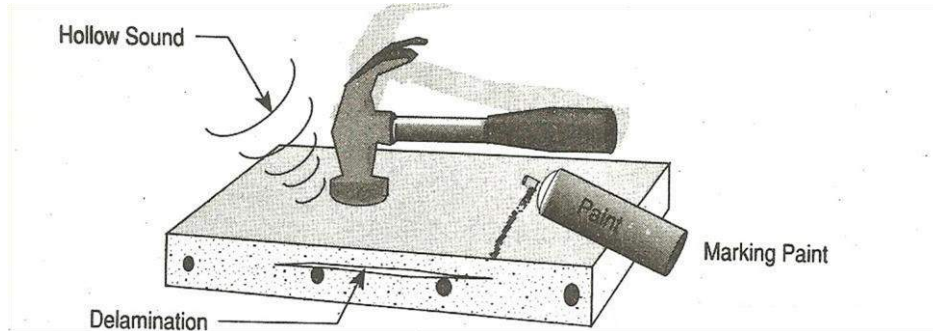

Application: To identify & locate the delamination in concrete

Advantage: low cost & time.

Limitations: since human perception has limitations, accuracy of judgements is sometimes questionable.

Rebound Hammer test: The rebound hammer also called Schmidt hammer – a swiss hammer is one of the oldest & best known methods for comparing the concrete in different parts of structure. A simple hand held device measures the hardness of concrete surface through a rebound of a spring loaded mass rebound measured on a graduated scale giving a “Rebound

Number” Larger the rebound number - harder the surface concrete. Most hammers come with a calibration chart relating the compressive strength of concrete and rebound number.

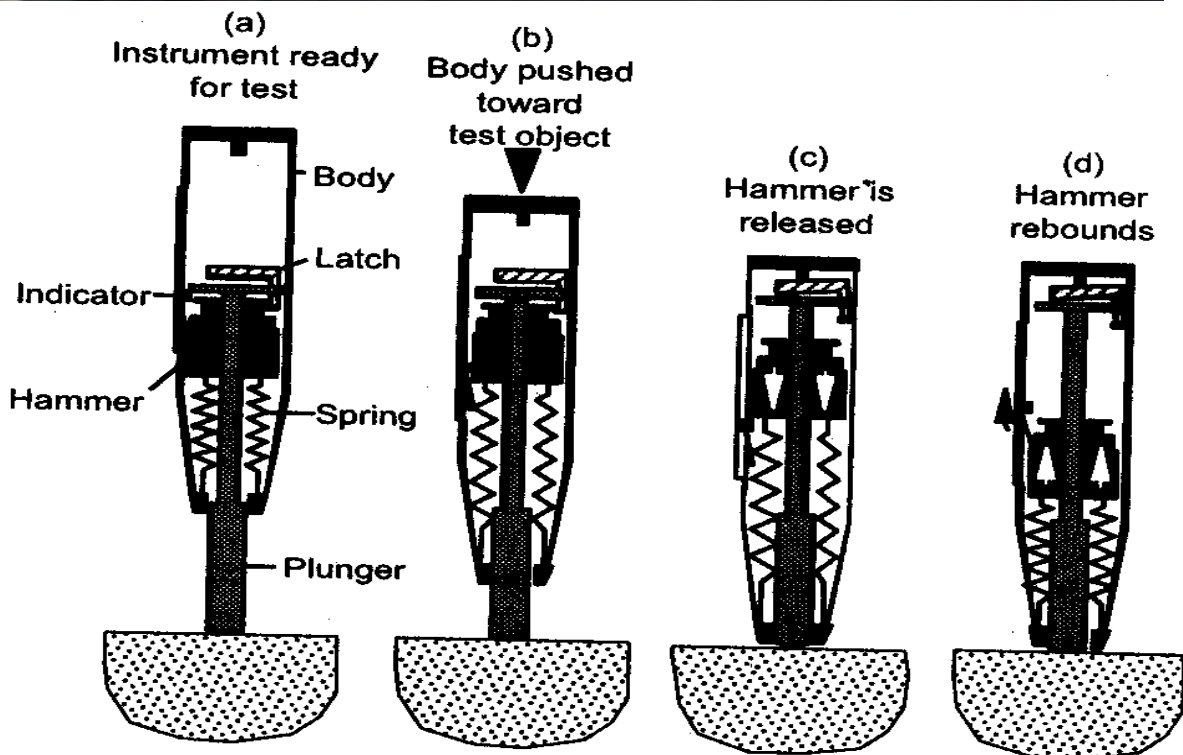

Schematic cross section of rebound hammer showing principle of operation.

Factors affecting rebound number readings

- Mix Characteristics- Cement type and content and coarse aggregate content.
- Angle of inclination of hammer
- Member Characteristics- Mass, compaction and surface type
- Age of concrete and Rate of hardening, curing type
- Surface texture
- Concrete mix characteristics
- Carbonated concrete, and
- Moisture content

Steps to be followed

- All members to be marked with well defined grid points - spacing of 200 - 300 mm preferred
- Each grid point to be cleaned and surface smoothed
- A minimum of 6 readings to be obtained at each point and average considered omitting too low and too high values.
- Do not repeat impacts on same point
- A hammer of 0.225 kg m impact energy used for normal concrete and structural members of medium size
- A statistical analysis gives indication on overall quality and variability
- Delamination of cover concrete can be identified
- low and very low rebound numbers
- Very high rebound numbers greater than 50- may represent carbonated concrete - to be confirmed by chemical test
- **Application:** This test is used for estimating the uniformity & quality of concrete, monitoring the strength development, in-situ strength estimation and assessing relative quality of structural members.
- **Advantage:** It is simple & quick method. A large number of measurements can be rapidly taken so as to map large exposed areas of concrete.

- **Limitation:** Results are affected by the angle of test, surface smoothness and mix proportions of concrete. It does not provide a reliable prediction of the strength of concrete. The possible error may be up to $\pm 25\%$.

Comparative hardness of the cover zone		
Instrument	Average rebound number	Quality of concrete
Schmidt hammer readings	<p>> 40</p> <p>30 to 40</p> <p>20 to 30</p> <p>10 to 20</p> <p>< 10</p>	<p>Very good</p> <p>Hard layer</p> <p>Good layer</p> <p>Fair</p> <p>Poor concrete</p> <p>Delaminated</p>

Ultrasonic pulse Velocity (USPV) test

It is most widely used test in evaluation of in-situ concrete. The method is based on the principle that the velocity of an ultrasonic pulse through any material depends upon the density, modulus of elasticity, the presence of the reinforcing steel & poision's ratio of the material.



PROCEDURE FOR UPV TEST

- Divide the members into well defined grid points - spacing of 200 - 300 mm preferred identical to rebound hammer survey
- Each grid point is prepared to obtain smooth surface - a thorough cleaning
- Application of acoustical coupling - grease, thick oil, petroleum jelly
- Transmitting the pulses by placing the transmitter and receiving at other end (50-54 kHz)
- Recording the transit time displayed by the instrument - a reliable steady reading to be recorded
- Measurement of length between transmitter and receiver
- Calculation of velocity, $V = L / T$ (L – Path length, T-time)

Behaviour of ultrasonic pulses in a concrete medium under different conditions

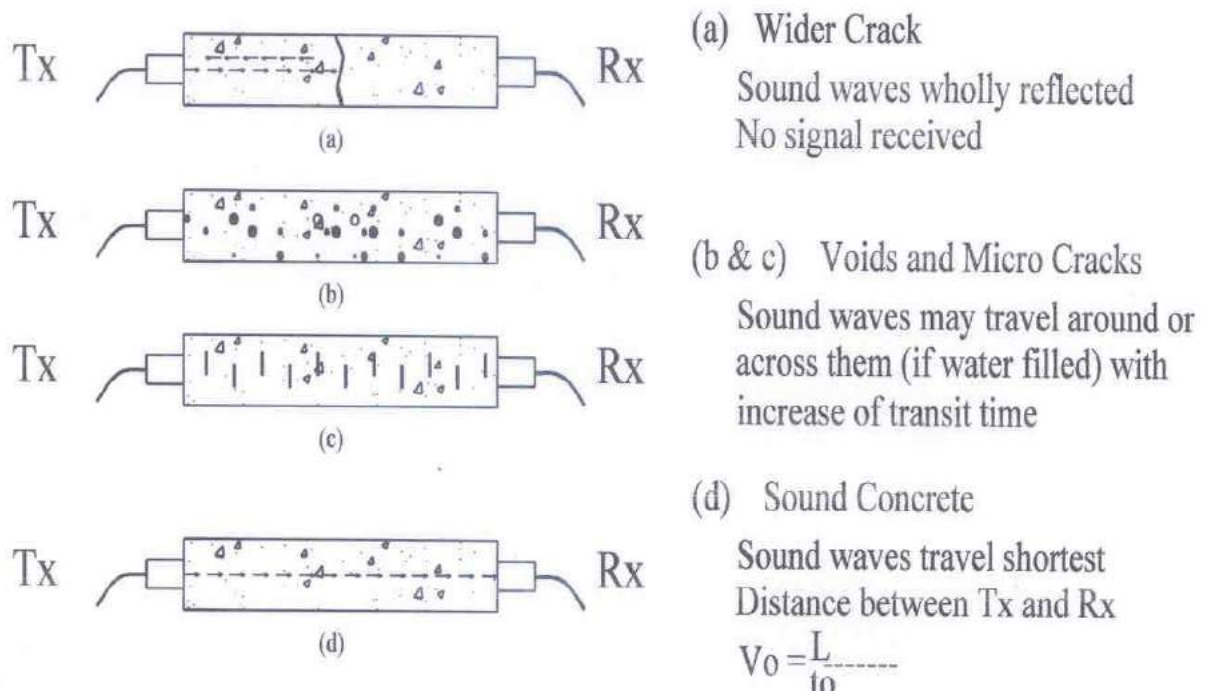

The principle of assessing the quality of concrete is that values of ultrasonic pulse velocities are found to be higher when it encounters a dense, homogeneous and uniform concrete along its path. Lower velocities are obtained in case of poorer quality.

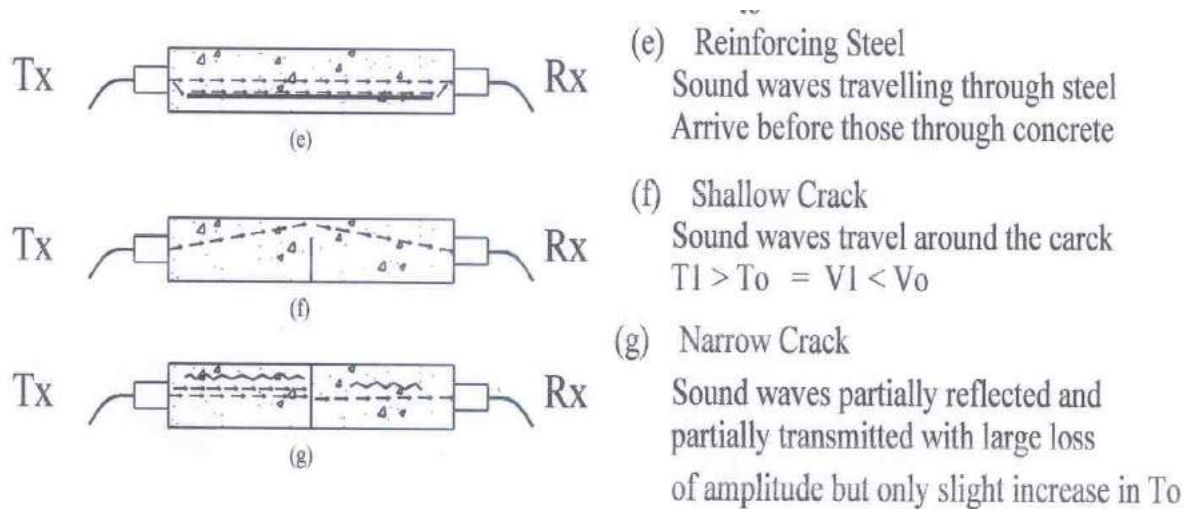

UPV value km/sec. (V)	Concrete quality
Greater than 4.00	Very good
Between 3.50 and 4.00	Good, but porous
Between 3.00 and 3.50	Poor
Between 2.50 and 3.00	Very poor
Between 2.00 and 2.50	Very poor and low integrity
Less than 2.00	No integrity, large voids suspected

Applications: The tests help to determine the homogeneity of concrete, changes in structure of concrete with time, to assess the extent and severity of cracks in concrete. Precisely describes the areas of deteriorated and poor quality concrete.

Advantage: The test equipment is portable, can be performed quickly and has sufficient power to penetrate about 11m in good continuous concrete.

Limitations: The test does not give the precise strength of concrete. A large number of factors affect the values of pulse velocity that include surface condition and moisture content, temperature of concrete, micro-cracks in concrete, age of concrete, presence of steel rfm, aggregate type, content & size. When the concrete is subjected to abnormally high stress, pulse velocity value is reduced due to development of micro-cracks.



IDENTIFICATION OF CORROSION PRONE-LOCATIONS BASED ON UPV AND REBOUND HAMMER READINGS

S. No	Test Results	Interpretation
1	High UPV Values, High Impact Hammer No.s	Not Corrosion Prone
2	Medium range UPV values, low impact hammer numbers	Surface delamination, low quality of surface concrete, corrosion prone
3	Low UPV, High impact hammer numbers	Not corrosion prone, however to be confirmed by chemical tests, carbonation, pH
4	Low UPV values, low impact hammer numbers	Corrosion prone-Requires chemical and electrochemical tests

Windsor Probe test

It is one of the most well-known penetration resistance methods. It is based on the determination of the depth of the penetration of probes (steel rods or pins) into the concrete. The apparatus used in this method is Windsor probe which is a special gun that uses a 0.32 Caliber blank with a precise quantity of powder to fire a high strength steel probe into concrete. The principle underlying the technique is that penetration depth is inversely proportional to the compressive strength of concrete, but the relation depends on hardness of aggregate. The minimum distance between the edge of concrete member should be of the order of 150 mm and that between the test positions be 200 mm.

The penetration will be effected by the presence of reinforcing bars within the zone of influence of the penetrating probe. Thus the location of the reinforcing steel should be determined prior to selecting test locations.

Manufacturers provide calibration charts of strength versus penetration for the normal probe for aggregates with hardness between 3 and 7 on Mohrs scale. However, the penetration resistance should be correlated with the compressive strength of a standard test specimen or core of the actual concrete used.

Application: This test is used for estimating the uniformity & quality of concrete. An area of poor concrete can be easily described by making a series of penetration tests at regular spaced locations. This method provides excellent means for determination of relative concrete strength in the same structure or in different structures without extensive calibration.

Advantage: The test equipment is simple, durable and requires less maintenance and can be easily used with least training given to inspectors. Can also be used in places where access is limited.

Limitation: It does not give reliable results on strength values. Type of aggregates affects the penetration depth; hence a separate calibration chart needs to be prepared for each type. This test damage the concrete leaving a hole of about 8 mm in diameter for the depth of the probe, hence minor cracks of exposed surface becomes necessary. Damage in the form of cracking may be caused in case of slender members.

Semi-destructive tests for strength estimation of concrete

Pull-off test: The pull-off test is used to determine the tensile strength of concrete by application of the in-situ concrete by application of direct tensile force. The test is also used for measuring the bond of surface repairs. A circular steel probe is glued to the concrete with an epoxy resin. Before applying the adhesive, the concrete surface is roughened with sandpaper and then degreased with the help of suitable solvent. After the epoxy resin has cured sufficiently, the metal disk is pulled off from the concrete surface manually or mechanically. The tensile strength of the bond being greater, the concrete fails in tension. The tensile force required to cause failure is recorded from which the tensile strength is calculated on the basis of the disk diameter i.e., 50

mm, and this may be converted to the compressive strength using a calibration chart appropriate to the concrete.

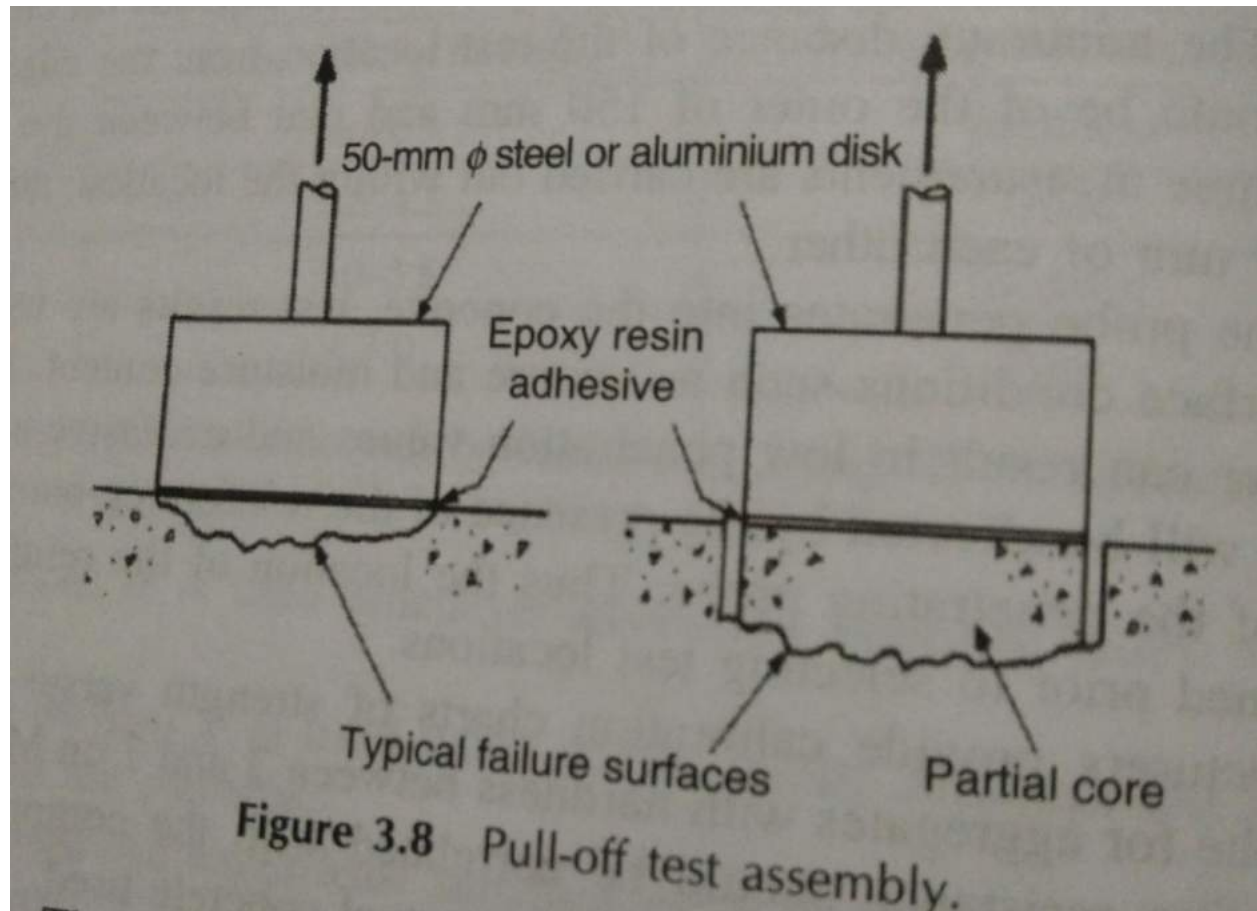

Application: Assessment of the bonding strength of all kinds of applied coatings & repairs.

Advantage: The test is simple & quick to perform. Damage caused to concrete is minor and can be repaired easily.

Limitation: The main limitation is the curing time of the adhesive which is 24 hours. During testing if adhesive fails because of its inferior quality, then the entire test result becomes meaningless. Hence, six discs are to be used to determine the strength.

Core Test: The testing of the cores cut from hardened concrete is quite a well established method used for visual and petrographic analysis of concrete. Cores are sometimes sectioned or drilled to provide samples for chemical analysis. Cores are usually extracted by drilling using a diamond tipped core cutter cooled with water.

The selection of location of the cores is made after conducting NDT which can give guidance on the most suitable area of extraction.

Cutting of cores require special equipment. Most of the cores are either 100 mm or 150 mm in diameter. If the core size is small in relation to the maximum aggregate size, then care must be taken during analysis. The choice of the core diameter will be influenced by length of the specimen. It is generally accepted that cores for compression testing should have a length/diameter ratio between 1 and 2. The measured compressive strength represents the equivalent strength of the cylinder having a slenderness ratio of w . Equivalent cube strength is determined by multiplying the corrected cylinder strength by $5/4$.

Application: The cores confirm the findings of non-destructive tests, and helps in identifying the presence of deleterious matter in concrete, ascertaining the strength of concrete for design purpose. Cores can also be used for measurement of density. This provides a useful indication of compaction and void age.

Advantage: Cores provide the simplest method of obtaining samples of in-situ concrete. Chemical analysis can be performed on the remains of crushed core. Visual inspection of the interior of concrete can prove to be very valuable where no records of concrete are available.

Limitations: The main limitation is the cost and inconvenience, damage and localized nature of the results. The test is possible only if the quality of concrete is reasonably good in the structure that is tested. If the quality is poor, then core samples will be vulnerable to damage during coring or testing operation.

Testing For Chemical Properties

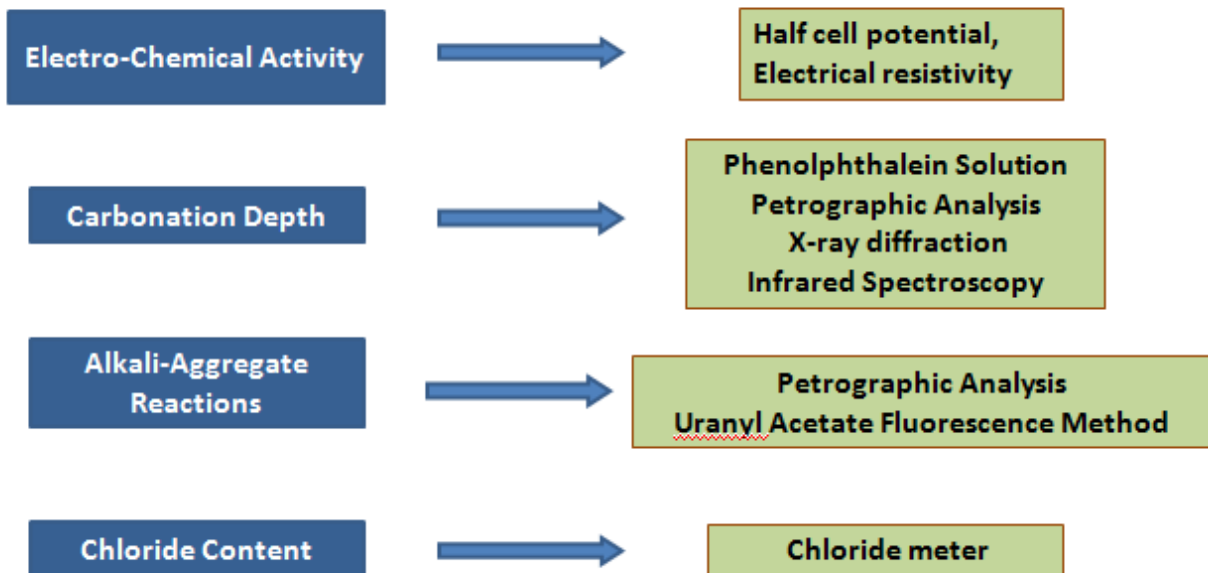

ELECTRO-CHEMICAL ACTIVITY (CORROSION ACTIVITY MEASUREMENTS)

I. Half Cell Potential Method (Open-Circuit Potential Measurement Technique)

During the active corrosion, the electrons released from the iron as it corrodes and electrons consumed by dissolved oxygen constitute a current that is accompanied by an electric potential field surrounding the concrete bar. The principle of half-cell electrical potential method involves measuring the potential of an embedded reinforcing bar relative to a reference half-cell placed on the concrete surface. The half-cell usually used are copper/copper sulphate or silver/silver chloride cell and standard calomel electrode. The concrete functions as an electrolyte.

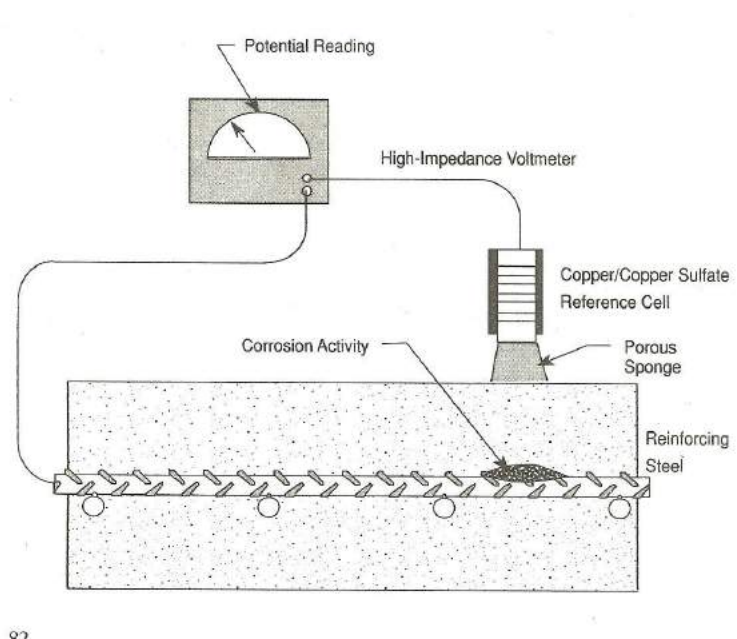

The measured voltage depends upon the type of half-cell. The positive terminal of the voltmeter is attached to the reinforcement and the negative terminal is attached to the half-cell placed on the surface of the concrete. The half-cell by means of a porous plug and sponge moistened with a wetting solution makes electrical contact with the concrete. The half-cell potential readings provide an indication of the probability of corrosion activity of the reinforcing bar located beneath the half-cell. The general guidelines for the interpretation of the half-cell potential readings for the corrosion activity is as follows

The general interpretations of half-cell potential measurements:

Less negative than -0.2 volts \Rightarrow No corrosion [90% probability]

Between -0.35 and -0.2 volts \Rightarrow corrosion activity [uncertain]

More negative than -0.35 volts \Rightarrow corrosion [90% probability]

Positive value \Rightarrow insufficient moisture in the concrete (invalid reading)

Application: This method is definitely restored for the assessment of durability of concrete structures when corrosion of reinforcement is suspected. It is used majorly in marine structures, bridge decks and abutments for assessing the corrosion risk.

Advantage: It is simple with simple equipment that provides a non-destructive survey for the presence of the active corrosion.

Limitation: This method provides an indication of the probability of the corrosion; however, it gives no indication of the rate of corrosion. Also for accurate results, the concrete should be sufficiently moist to complete the circuit. The method cannot be applied to concrete with coated surfaces or reinforced with epoxy coated reinforcing bars. The test is difficult to apply for post-tension strands. The test fails if there is discontinuity in the reinforcement.

II. Electrical Resistivity/Concrete Resistivity

Whilst the half cell potential measurement is effective in locating regions of corrosion activity, it provides no indication of the rate of corrosion. Electrical resistivity measurements give further insight into corrosion.

PRINCIPLE:

A low resistance path between anodic and cathodic sites would normally be associated with a high rate of corrosion than a high resistance path. Electrical resistivity measurements determine the current levels flowing between anodic and cathodic portions, or the concrete conductivity over the test area, and are usually used in conjunction with the half-cell potential technique. This is an electrolytic process as a consequence of ionic movement in the aqueous pore solution of the concrete matrix.

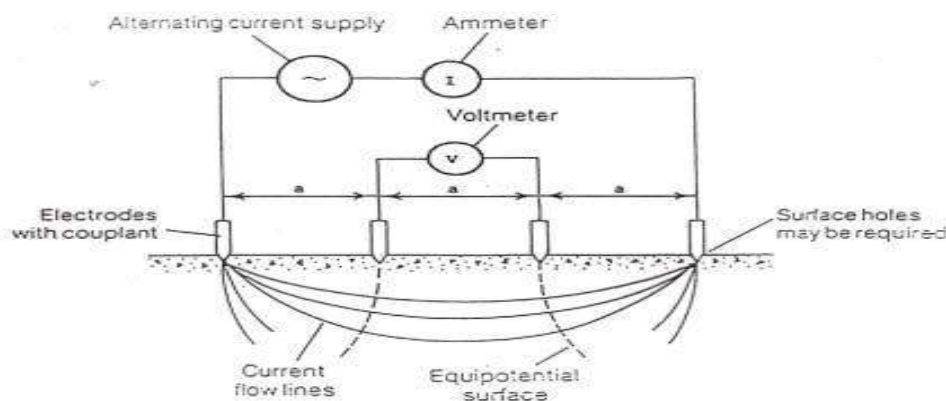

EQUIPMENT: Wenner 4 Probe Resistivity Meter

The equipment consists of four electrodes (two outer current probes and two inner voltage probes) which are placed in a straight line on or just below the concrete surface at equal spacings. A low frequency alternating electrical current is passed between the two outer electrodes whilst the voltage drop between the inner electrodes is measured.

The apparent resistivity (ρ) in “ohm-cm” may be expressed as:

$$\rho = 2\pi aV/I$$

where

V is voltage drop,

I is applied current,

a is electrode spacing.

The spacing of the four probes determines the regions of concrete being measured. It is generally accepted that for practical purposes, the depth of the concrete zone affecting the measurement will be equal to the electrode spacing. If the spacing is too small, the presence or absence of individual aggregate particles, usually having a very high resistivity, will lead to a high degree of scatter in the measurement. Using a larger spacing may lead to inaccuracies due to the current field being constricted by the edges of the structure being studied. In addition, increased error can also be caused by the influence of the embedded steel when larger spacings are employed. A spacing of 50 mm is commonly adopted, gives a very small degree of scatter and allows concrete sections in excess of 200 mm thick to be measured with acceptable accuracy.

Factors influencing Electrical Resistivity Measurements

1) Moisture

2) Salt content

3) Ambient temperature,

4) Water/cement ratio and

5) Mix proportions.

The variations of **moisture condition** have a major influence on *in situ test readings*. Precautions need to be taken when comparing results of saturated concrete, e.g. those exposed to sea water or measurements taken after rain showers, with those obtained on protected concrete surfaces.

Ambient temperature: Concrete has electrolytic properties; hence, resistivity will increase as temperature decreases. Usually resistivity measurements are higher readings during the winter period than the summer period.

General Guidelines for Interpretation of Resistivity Measurements for Corrosion Assessment

Resistivity (ohm cm)	Likely Corrosion Rate
Less than 5,000	Very high
5,000 – 10,000	High
10,000 – 20,000	Low / Moderate
Greater than 20,000	Negligible

It is necessary to calibrate the technique, either through exposing the steel to assess its condition, or by correlating the resistivity values with data collected with other techniques, such as half-cell potential measurement.

Application: The principal application of this technique is for the assessment of the corrosion rate when used along with other corrosion tests such as half-cell potential or polarization method.

Advantage: This technique helps to determine the resistivity of concrete quickly with little or no damage to the concrete structure. A high resistivity indicates that even though steel is corroding as determined from half-cell potential tests, the rate of corrosion may be low.

Limitation: The resistivity values may be greatly affected by the spacing of the electrodes, the depth of concrete member, depth of cover and reinforcing bars. The test results are affected by pore solution conductivity and moisture condition of specimen.

Polarization Resistance Technique: This technique is used for the measurement of the in-situ corrosion rate. The principle involves measuring the change in the open-circuit potential of the short circuited electrolytic cell when an external current is applied to the cell. In this technique, a very small electrical potential (E) is applied to the corroding steel by means of an auxiliary electrode placed on the surface of the concrete as shown in fig. On application of this slight perturbation, a measurable current flow is produced which is proportional to the corrosion current, I_{corr} .

The polarization resistance R_p is the ratio of the change in potential to the current density

$$R_p = E/I$$

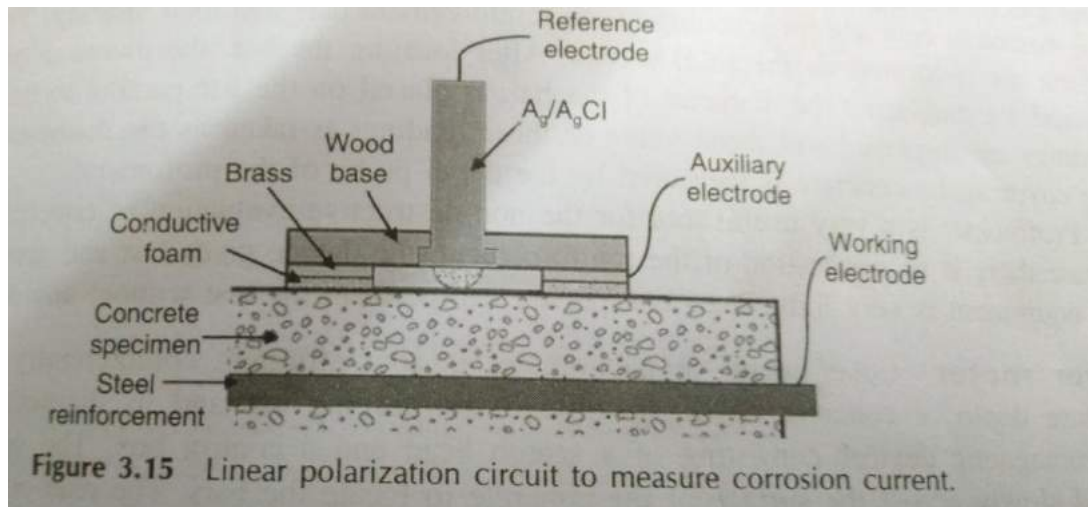

The real corrosion current I_{corr} can be derived based on Stern and Geary, 1957 equation:

$$I_{corr} = B/R_p$$

Where B is a constant which is a characteristic of the polarization curves and a value of 26 mV is commonly used for steel that is actively corroding in concrete.

Application: It is well-established method of determining the instantaneous corrosion rate measurement of reinforcing steel in concrete.

Advantage: The technique is rapid, non-intrusive and requires only a connection to the reinforcing steel.

Limitation: The choice of the correct value of the constant B requires a thorough knowledge of the corrosion state of steel. The exact area of the steel measured is sometimes not clear and some amount of uncertainty always prevails due to local pitting.

OTHER METHODS for determining corrosion activity:

4. Surface Potential Measuring Technique

5. Electrochemical Noise Analysis

Cover Thickness Measurements: The cover thickness is useful to measure the thickness of the cover to the reinforcing bar at specific locations. An adequate cover is must to control corrosion. The depth of reinforcement, the size of the bar, position and direction below the surface of the concrete can be measured non-destructively using magnetic devices like profometer or pachometer or cover meter.

Profometer: Profometer is a small, versatile instrument for detecting location, size of the reinforcement bar and concrete cover. It is a portable and handy instrument which is normally used to locate the reinforcement on the LCD display. It is based upon measurement of change of an electromagnetic field caused by steel reinforcement embedded in concrete. The path measurement and scanning of the rebars is done with the help of path measuring device and spot probes together. The latter is connected with the profometer with cables and moved on the surface of concrete for scanning reinforcement bars and their spacing. The detection of the bar is located on the LCD screen. After locating the bar, diameter probe, which is used for measuring diameter of the bar, is placed on the bar parallel to the bar axis. Four readings are displayed and mean value of these readings is taken as the diameter of the bar. The cover to the concrete is measured by the depth probe of the profometer.

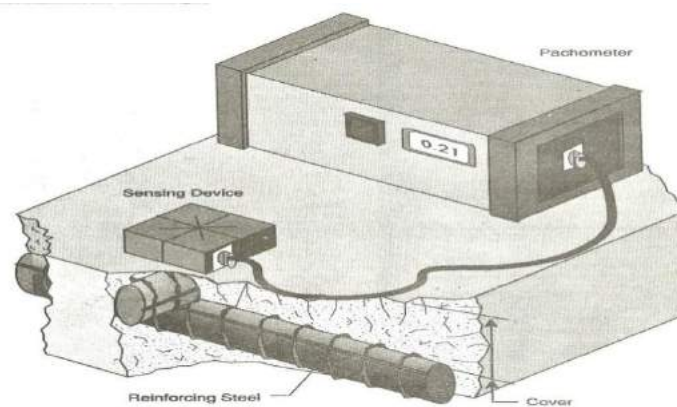

Profometer is a very useful tool for the non-destructive evaluation of concrete structures. In case there is no congestion of the reinforcement, the device gives fast and accurate results. The equipment is very light, even one person can perform the test without any assistance.

Cover Meter: Cover meter or pachometer is an instrument commercially available to measure depth of the concrete cover, location of reinforcing bar and its diameter. These are electromagnetic devices consisting of a search head and a control box. The search head is moved slowly across the surface of the concrete to locate the bars. The read-out is observed until a minimum is reached and the position of the head is noted by marking the position on the surface of the concrete. When the location of the bars in one direction has been established, the search head is moved in the perpendicular direction between the previously marked bar positions to locate the other bars. If the size of the reinforcing bar is determined, then the amount of concrete cover can also be determined. The depth of the concrete cover, thus determined can indicate the possibility of the onset of the corrosion in new structures and the probable extent of corrosion in old structures. The size of the reinforcing bar, thus obtained will help to indicate loss of cross section, if any due to corrosion.

OF CORROSION.

TABLE 3.6 Relationship between the Cover Thickness and Corrosion Risk

Sr. No.	Test results	Interpretation
1	Required cover thickness and good quality concrete	Relatively not corrosion prone
2	Required cover thickness and bad quality concrete cover	Corrosion prone
3	Very less cover thickness yet good quality concrete	Corrosion prone

The limitation of the cover meter is the choosing of the inspection location when the bars are closely spaced or are overlapped. The more congested is the reinforcement, including multiple layers, the less accurate the devices becomes. The accuracy of these devices is inversely proportional to the amount of steel present in the concrete. These devices can determine the depth of the concrete cover to an accuracy of 6mm when the reinforcement steel is at depth of 0-75 mm.

Some cover meters are affected by the presence of certain types of cementitious material and certain type of aggregates. In such situation, it becomes necessary to break the concrete to check the actual reinforcement diameter and depth to be assured of the readings of the cover meter.

Chemical Tests of concrete

Chemical tests of the concrete subjected to the environmental attack can provide a great deal of information regarding the exact cause of the damage. It is known fact that the corrosion of the reinforcing steel occurs when the protective passivating film on the steel surface formed due to high alkaline condition of the concrete, is destroyed by carbonation or chloride diffusion. Chemical tests like carbonation test and chloride content test help to determine the amount of diffusion of these atmospheric pollutants inside the concrete surface.

Carbonation Test

For the carbonation induced corrosion, determination of the depth up to which the concrete has become acidic becomes very crucial, In this test, the assessment of the carbonation depth is done by spraying solution of Phenolphthalein indicator on concrete surface. This solution appears pink when it comes in contact with un-carbonated concrete with the pH values above 9, or else it appears colourless when it comes in contact with carbonated concrete, i.e., Concrete with lower values of pH.

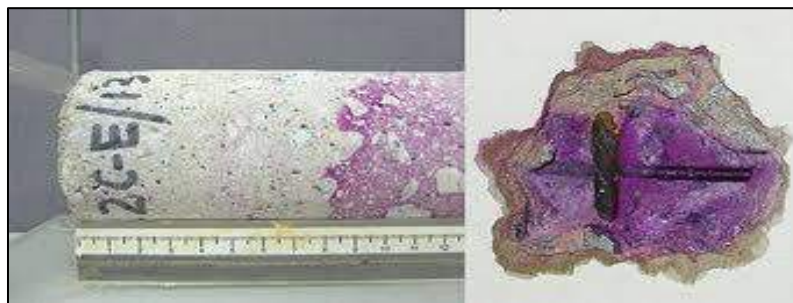

The test is most commonly carried out by spraying 0.2% solution of phenolphthalein in ethanol on freshly exposed surfaces of concrete broken from the structure or on split cores. Sometimes the powder from drill holes can also be sprayed or allowed to fall on phenolphthalein impregnated paper. The test must be applied only to freshly exposed surfaces, because the reaction with atmospheric carbon dioxide starts immediately.

II. Petrographic Analysis: Petrographic analysis is a technique developed in the earth-sciences for observation of rocks and minerals. It involves creating a "thin-section" of the material being studied. Once the thin-section is made it is viewed through a polarising microscope, which has two polarizing filters oriented at right-angles to each other, thereby blocking out any light . However, a sample containing minerals may diffract the light, so that they are visible in cross-polarized light. The degree of diffraction is a key characteristic enabling identification of the crystals.

The petrographic examination helps to improve the extrapolation from test results to performance in situ. Together with various other concrete tests, petrographic analysis helps to determine why this concrete in situ behaved in the way it did, and how it may behave in the future.

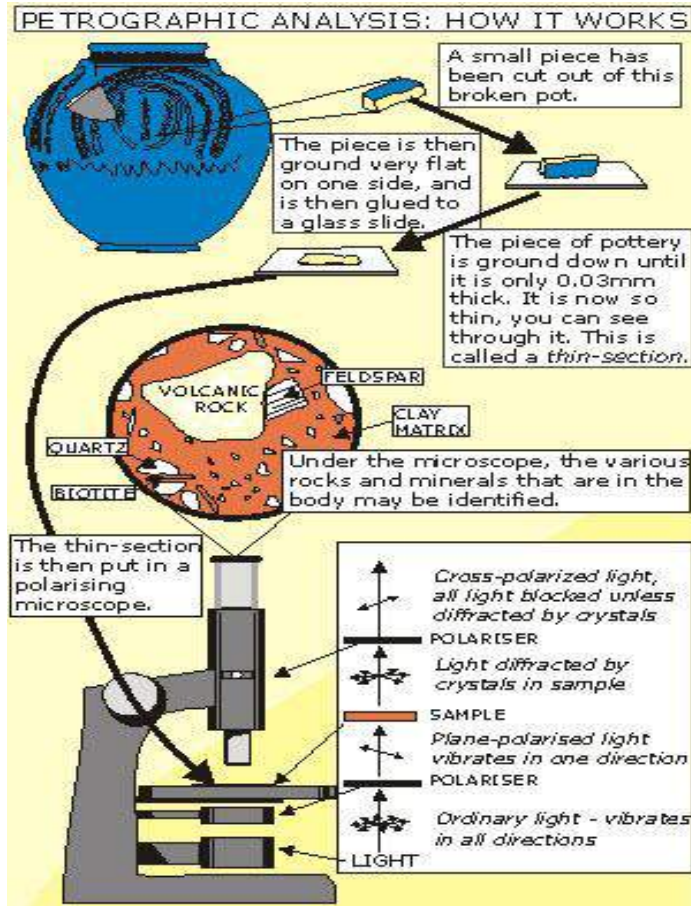

To perform this type of analysis, concrete specimens are taken from the structure and are prepared by either polishing or etching a surface of the specimen. Petrographic examination includes identification of mineral aggregates, aggregate-paste interface, assessment of the structure, and integrity of the cement paste.

Petrographic examination helps determine some of the following mechanisms:

- 1) Freeze-thaw resistance**
- 2) Sulfate attack**
- 3) Alkali-aggregate reactivity**
- 4) Aggregate durability**
- 5) Carbonation**

Chloride Content Measurement

It is done by taking a sample of concrete from the structure, either by drawing pulverized concrete using a rotary-percussion hammer(preferably electric), or by taking cores and then pulverizing the concrete in the laboratory.

At each level of sampling, the pulverized material is collected and stored in a clean container, the hole is vacuum cleaned, and the next sample is drawn at the next desired depth. Where deep holes are to be drilled, care must be taken to prevent contamination of the sample from the abrasion of the rotary drill bit against the side of the hole. Using a drill bit with a stepped-down bit diameter will reduce the chance of contamination. Powdered samples are analyzed using a wet chemical method.

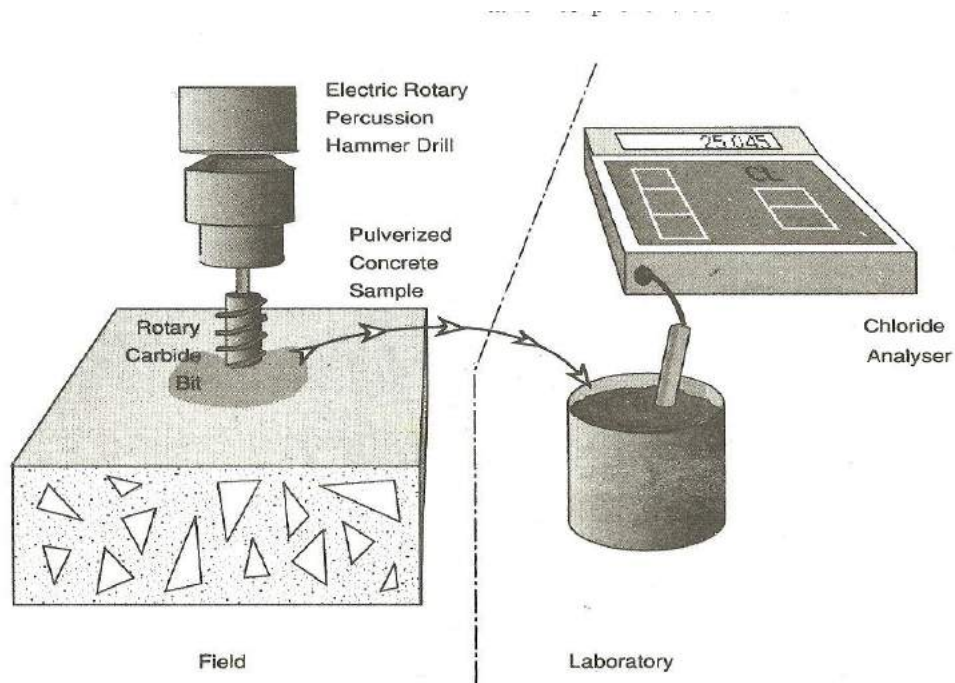

The **Chloride Field Test System** measures the amount of chloride present in wet or dry concrete. The **C-CL-2000** produces results on-site, within minutes that are accurate and

comparable to expensive laboratory tests. It measures the electrochemical reaction of a weighted sample placed in an extraction liquid. It automatically shows a temperature compensated reading of percent of chlorides on its digital display. A wide range - from 0.002 to 2% chloride by weight - is covered.



A sample of powder is obtained by drilling and careful quartering. Then an accurately weighed 3 gr. sample is dissolved in 20 ml of extraction liquid which consists of a precise, measured concentration of acid. For sampling wet concrete a 3 gr. sample of mortar is used.

The chloride ions react with the acid of the extraction liquid in an electrochemical reaction. An electrode, with integral temperature sensor, is inserted into the liquid and the electrochemical reaction measured. A uniquely designed instrument converts the voltage generated by the chloride concentration. The instrument automatically applies the temperature correction and it shows the chloride concentration on a LCD display in either lbs. per cu. yd. or percentage by weight. Once the sample is obtained, test results can be determined and read in less than five minutes.

DELAMINATION / VOIDS DETECTION

- Hammer Sounding
- Chain Drag
- Acoustic Emission technique
- Pulse echo technique
- Impact Echo technique
- Exploratory Removal

- Remote Viewing (TV, borescope)
- Infrared Thermography

Acoustic Emission technique

Acoustic emission (AE) is a non-destructive method that analyses the noise created when materials deform or fracture. Acoustic emissions are the micro-seismic activities that originate from the test specimen when subjected to an external load. The principle underlying the technique is that whenever a material is loaded, localized points get strained beyond their elastic limit which leads to crushing or micro-cracking. The kinetic energy, thus released will propagate small amplitude elastic stress waves throughout the element known as acoustic emissions. These emissions are not audible, but they can be detected on the surface by a sensor, which turns the vibrations into electrical signal.

The detected signals are amplified, filtered, processed and recorded in some convenient form such as a plot of emission count rate against applied load. A number of piezoelectric transducers are located on the surface to capture the area of interest. AE techniques are extensively used to detect the region of discontinuous micro-cracking ahead of the visible crack. It is also used to detect cracks in concrete due to drying shrinkage and thermal stresses. The drawback of this technique is that the equipment cost is high and use is restricted to the laboratory. The acoustic emissions are generated only when the loads on the structure are increased, and this may create considerable practical problems.

The major difference between ultrasonic pulse method and AE is that in the USPV, a known signal is imparted into a material and the response of the signal is studied, while in AE method, the signal is generated by material itself.

Radar technique

This technique is gaining acceptance as a useful and rapid method for the non-destructive detection of delaminations, thickness of structural members, spacing and depth of reinforcement detecting the position and extent of voids and many other types of defects in bare or overlaid reinforced concrete bridge decks. A basic radar system consists of a control unit, antennas-one for transmitting and one for receiving pulses-an oscillographic recorder and a power converter for DC operation.

In this technique, the radar generates electromagnetic pulses which are transmitted to the concrete member under investigation by means of an antenna close to its surface. The pulse travels through the underlying material and its propagation velocity is determined by the electrical permittivity. These pulses during propagation get partially reflected and refracted on encountering an interface with distinct dielectric characteristics such as presence of a void, moisture content and reinforcement. These reflected pulses are received by an antenna that generates an output signal which provides an evaluation of the properties and geometry such as the depth of the interface under investigation.

The major limitation of this technique is the large amount of data and the interpretation of different radar signals which is difficult to analyze. The test also is less effective in case the deck surface is wet.

Stress Wave propagations methods

There are a number of NDT methods which is based on the concepts of stress wave propagations in continuous medium. The fundamental principle of these methods is the manner in which a wave reflects and refracts within a solid material can provide vital information about its internal heterogeneity. The most common technique used is pulse echo and impact echo technique.

Pulse Echo Technique

Pulse echo technique has been widely used with success in detecting very large structural cracks in concrete dams, piles, caissons and piers to locate honeycombed concrete and under-grouted metal ducts. The principal underlying the method is that internal defects and the boundaries of the object will reflect incident stress waves and the reflected waves will travel back to the surface. In this method, a transmitter introduces a stress pulse into an object at an accessible surface. This technique is most widely developed for testing of concrete piles.

A transient stress below is introduced at the pile top or onto a test object by a point impact. At opposite face, they get reflected and propagate back to the test object. This leads to a transient resonance condition set up by multiple reflection of waves between the top surface and internal flaws or external boundaries. A displacement transducer located close to the impact point is used to monitor the surface displacement caused by the arrival of these reflected waves. The analysis of the amplitude of the reflected waves helps to detect any defects or lack of uniformity of the pile.

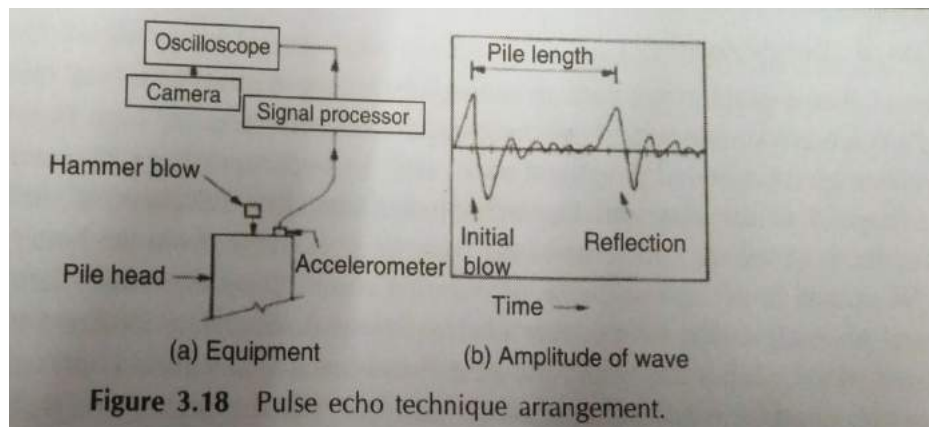
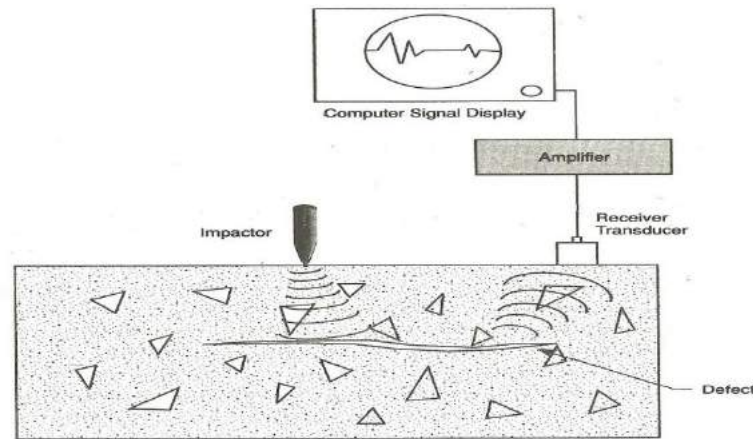

Figure 3.18 Pulse echo technique arrangement.

This technique is however, not used for testing of concrete in the field because of the practical problem of manufacturing large sized transducers. Another limitation is that the method requires a high degree of experience, a thorough knowledge of interpretation of results and very sophisticated time measuring device is required.

Impact Echo Method

This technique is a recent development in instrumentation and computer technology that provides a reliable method of locating voids, cracks, honey combing and other flaw under the surface of concrete. The impact echo technique works by impacting the concrete surface with a short duration stress pulse that is reflected from defects and external boundaries back to a receiver as shown in figure. In this method, a transient stress pulse is introduced into a test object by a mechanical point contact impactor on the surface. At the point of impact, spherical compressive and shear waves are generated, and they travel radially inside the material, while the surface waves travel away from the point of impact.



The interaction of the compression and shear waves with any kind of heterogeneity or an external boundary or defects cause them to be reflected back to the surface. A transducer placed on the concrete surface

Remote Viewing

Since access to certain parts of structures may be limited, remote viewing may be the only way to inspect these areas. Fiber optics (borescope), video cameras, and periscopes are tools that allow for remote viewing. The fiber optics method utilizes a bundle of glass fibers that transmit light to the subject being viewed. Images are then transmitted back to a lens for viewing by eye or camera.

With this method, views are limited to small areas, since drilled holes can be as small as 1/2" (1.27 cm) for penetration of the borescope. Use of video cameras and periscopes requires larger drilled holes and provide a larger viewing area of the subject.

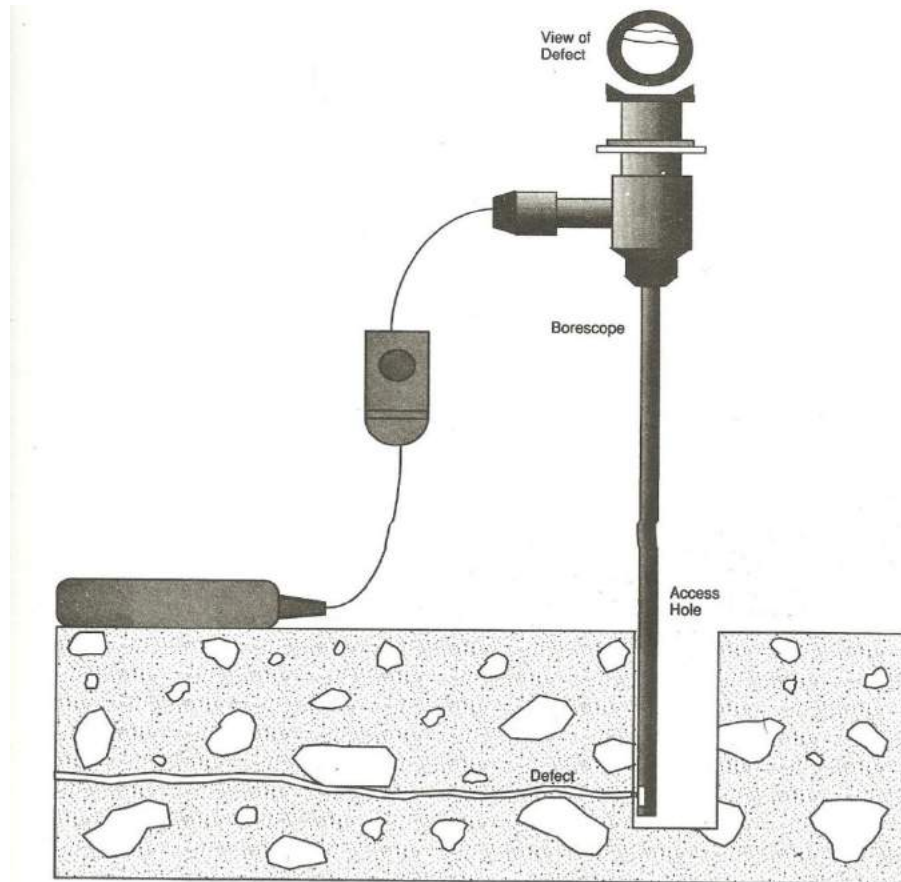

Infrared Thermography

IR thermography is a method for measuring the temperature distribution of a surface. It permits to detect regions of heat production (e.g. due to a crack under cyclic loading or a hot spot in a defective IC) or regions of inhomogeneous cooling (e.g. due to blisters or air voids in a pavement or under waterproof membranes). In the building phase of road constructions, IR thermography can be used to control the temperature of the single components. When flashes or a sine-modulated radiator heat an object, voids and debondings buried below the surface hinder the heat transfer. The resulting transient thermal contrast on the surface is made visible with pulse or lock-in thermography.

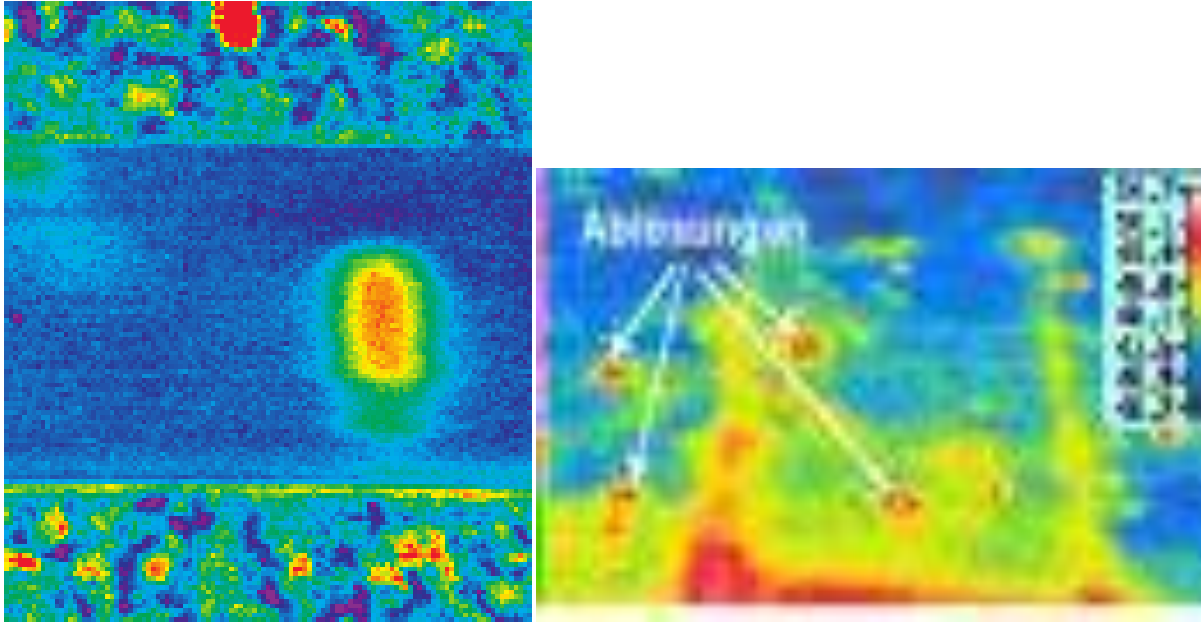

Durability Tests on concrete

Initial Surface Absorption Test (ISAT)

Initial surface absorption is defined as the rate of flow of water into concrete per unit area at a stated interval from the start of the test at a constant applied head and temperature. The principle underlying the test is based on the assumption that the dried concrete absorbs water by capillary action at a rate which is initially high, but decreases as the water filled volume of capillaries increases.

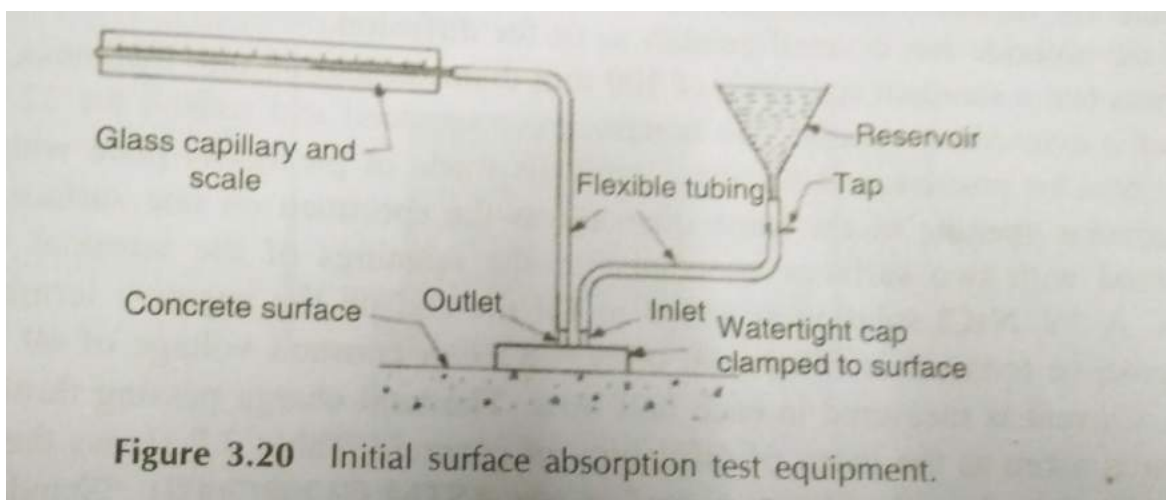

The equipment consists of a cap that seals the concrete surface and is connected to a water reservoir and a calibrated capillary tube. The water contact area must be of 5000 mm² and the

reservoir attached to the cap is filled with water such that the water level is 200 mm above the concrete surface. In the beginning of the test, the reservoir tap is opened and water flows and fills the cap. During this stage, the capillary tube is disconnected from the outlet so that the air is properly driven out. The water level in the reservoir is to be maintained at constant head. The calibrate capillary tube which is filled with water, is placed on the same horizontal line as the water surface in the reservoir. At specified intervals, say, an interval of 10 min, 30 min, 1 hr and 2 hr from the start of the test, the inlet valve below the reservoir is closed, and the rate at which the water is absorbed into the concrete is measured by the movement of water in the capillary tube is timed thereby giving the flow. A stopwatch is used to measure the number of scale units moved.

Modified figg permeability test

This test is used to determine the air or the water permeability of the surface layer of the concrete. In this test, a hole of 10 mm diameter, 40 mm deep normal to the concrete surface is drilled with a masonry drill. The hole is carefully cleaned and a disk of foam plugs the free surface of the hole. It is finally sealed with **liquid silicon rubber**. After the rubber gets hardened, a hypodermic needle is inserted through the plug and a water head of 100 mm is applied. A two-way connector is used to connect this to a horizontal capillary tube set 100 mm above the base of the cavity and syringe. Water is injected by syringe to displace all the air. A calibrated tube determines the volume of the absorbed water.

The same apparatus is used to determine the air permeability by replacing the syringe with a vaccum pump and a pressure guage. The pump reduces the pressure inside the hole, initially at atmospheric pressure to a specified value in order -55 kPa. The valve is now closed and a measurement is taken of the time it takes for the air flow to reach the hole and increase the pressure to a prescribed value. The time in seconds that it takes to finish the test is called the air-permeability index. The less permeable concrete will have high air-permeability index.

Rapid chloride ion permeability test

This test is based on the principle that charged ions, such as chloride ions Cl^- will accelerate in an electric field towards the pole of opposite charge. Chloride ions are usually selected as a medium for diffusion testing because chloride ion diffusion cause steel corrosion and the size of the chloride ion is small enough to fit for diffusion.

In this test a standard specimen of 100 mm diameter and 50 mm thickness, is cut from the centre of a cylindrical sample. The specimen is vacuumed and soaked for 22 hours. The test facility includes positive and negative terminals made of plexiglass plate with an empty cell and a circular opening of the same diameter as the specimen on one surface. The specimen is mounted with two surfaces connected to the openings of the terminal using a sealing material. A 3% NaCl solution is added to fill the cell on the negative terminal and the cell on the positive terminal is filled with 0.3 N NaOH. A constant voltage of 60 V is applied for 6 hours. Current is

measured in each half hour. A total charge passing through the concrete specimen is taken as the index of diffusivity of concrete. Table shows the rate of chloride ion diffusion based on the charge passed as per ASTM C 1202(2008), “Standard Test Method for Electrical Indication of Concrete’s ability to resist chloride ion penetration”.

Charge passed (coulombs)	Chloride ion Penetrability
>4000	High
2000-4000	Moderate
1000-2000	Low
100-1000	Very Low
<100	Negligible

Sorptivity test

This test method measures the rate of movement of water front through the concrete under capillary suction. The test method is based on measuring the weight change of a cylindrical sample that is previously conditioned. One of the flat face of the specimen is kept in contact with water, which gets absorbed by capillary absorption. The opposite face is exposed to the atmosphere while the curved surface is sealed to prevent water penetration. Sorptivity is derived from the plot of the cumulative change in mass divided by the exposed area and density of water, versus the square root of time. Slices of cores can also be used as sample for test after conditioning. The quality of concrete can be classified as per the sorptivity values given in table below

Water sorptivity mm/ square root (h)	Concrete quality
< 6	Very good
6-10	Good
10-15	Poor
>15	Very Poor

Oxygen Permeability test

This test measures the pressure decay of oxygen passed through an oven dried sample which is placed in a falling head permeameter. The schematic arrangement of the oxygen permeability test method is shown in fig. The concrete samples are generally 70 mm in diameter and 25 mm to 30 mm thick. Samples are oven dried at 50⁰ C for 7 days. The specimen is then placed in a pressure vessel with an airtight sealing. The pressure vessel is then pressurized to oxygen pressure of 100 kPa, after which the connection to the oxygen cylinder is cut and sealed.

The only exit for oxygen is then through the concrete specimen fitted in the rubber collar. The pressure decrease in the vessel is in function of time. Based on the Darcy’s equation for

permeation, the oxygen permeability index (OPI) is determined from the slope of the line produced by this plot. The OPI is defined as the negative log of the coefficient of permeability. The higher is the OPI index, the less permeable is the concrete. Table below gives the classification of quality of concrete based on the oxygen permeability index.

Oxygen Permeability index (OPI)	Concrete Quality
>10	Very good
9.5-10	Good
9.0-9.5	Poor
<9	Very Poor

Interpretation and Reporting of NDT Results

Various non-destructive testing techniques are used to assess the structure's material condition and quality as well as in-service durability of the component of structures. The information gathered during the investigation and the results of the NDT must be properly analyzed and tabulated in the specific format. The results may also be supplemented with required photographs and laboratory test results.

The summary of results along with the acceptability criteria must be clearly mentioned. The variability of the results and the statistical data if any, must be clearly stated. The results of the visual inspection followed by the NDT on the distressed element can be presented in the form shown in Table.

Sr.No	Element/Component	Location/Identity	Type of the defect observed	NDT results	Remarks

Final Report of Detailed Investigation

The report must include the following:

1. **Executive summary:** This section must capture all the essential facts related to the investigation in a clear and concise manner
2. **Introduction:** The following details must be encapsulated in this section of the report
 - Purpose and scope of investigation
 - Scope of work
 - Details of existing construction and documentation
 - Project inputs
 - Description of investigation

3. **Detailed investigation results:** This includes the key findings of the destructive and non-destructive testing performed during the investigation
4. **Evaluation and interpretation of results:** It includes the summary of the various test results
5. **Conclusion and findings:** this section must summarize the findings of the visible and non-visible defects, current rate of deterioration in structure, impact of deterioration on long-term durability/service life, current condition of the structure and feasibility of rehabilitation.
6. **Recommendations and Proposed methodology of repair/rehabilitation:** This section of the report must address the following: action plan, cost estimates, scheduling and determination of constraints and feasibility of carrying out the proposed methodology of remediation. This section must clearly recommend the methodology taking into considerations the enlisted factors:
 - Available space and accessibility
 - Prioritization of repairs and their sequencing
 - Propping of the structural members to relieve a part or full component of the load acting on the member
 - Safety measures to avert any mishap during the remediation work

NDT SUMMARY

What test should you adopt?

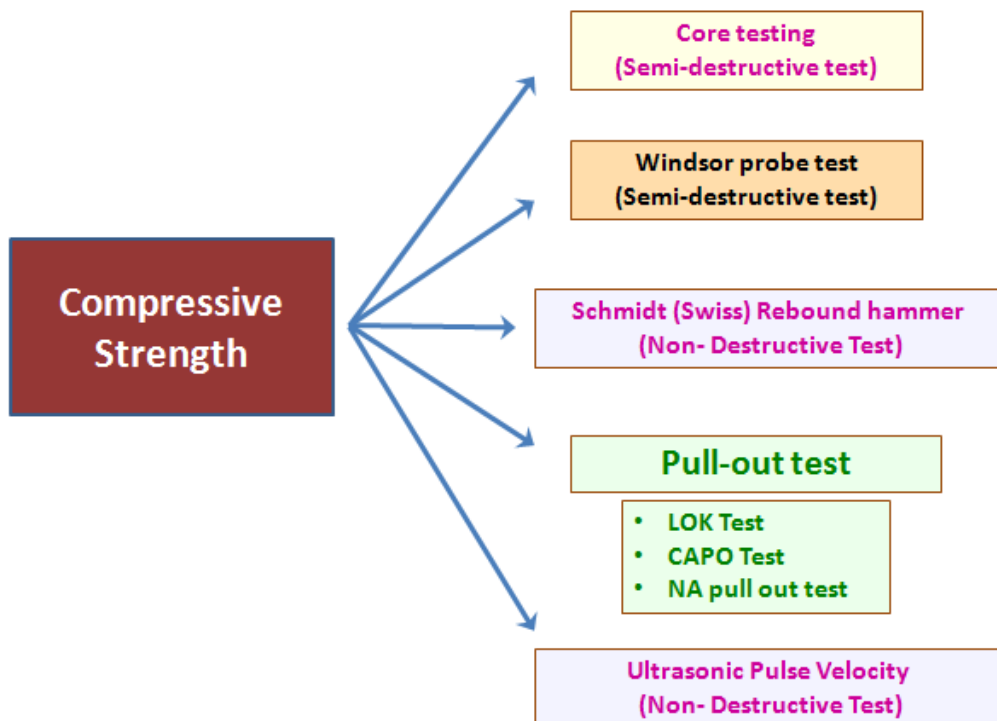

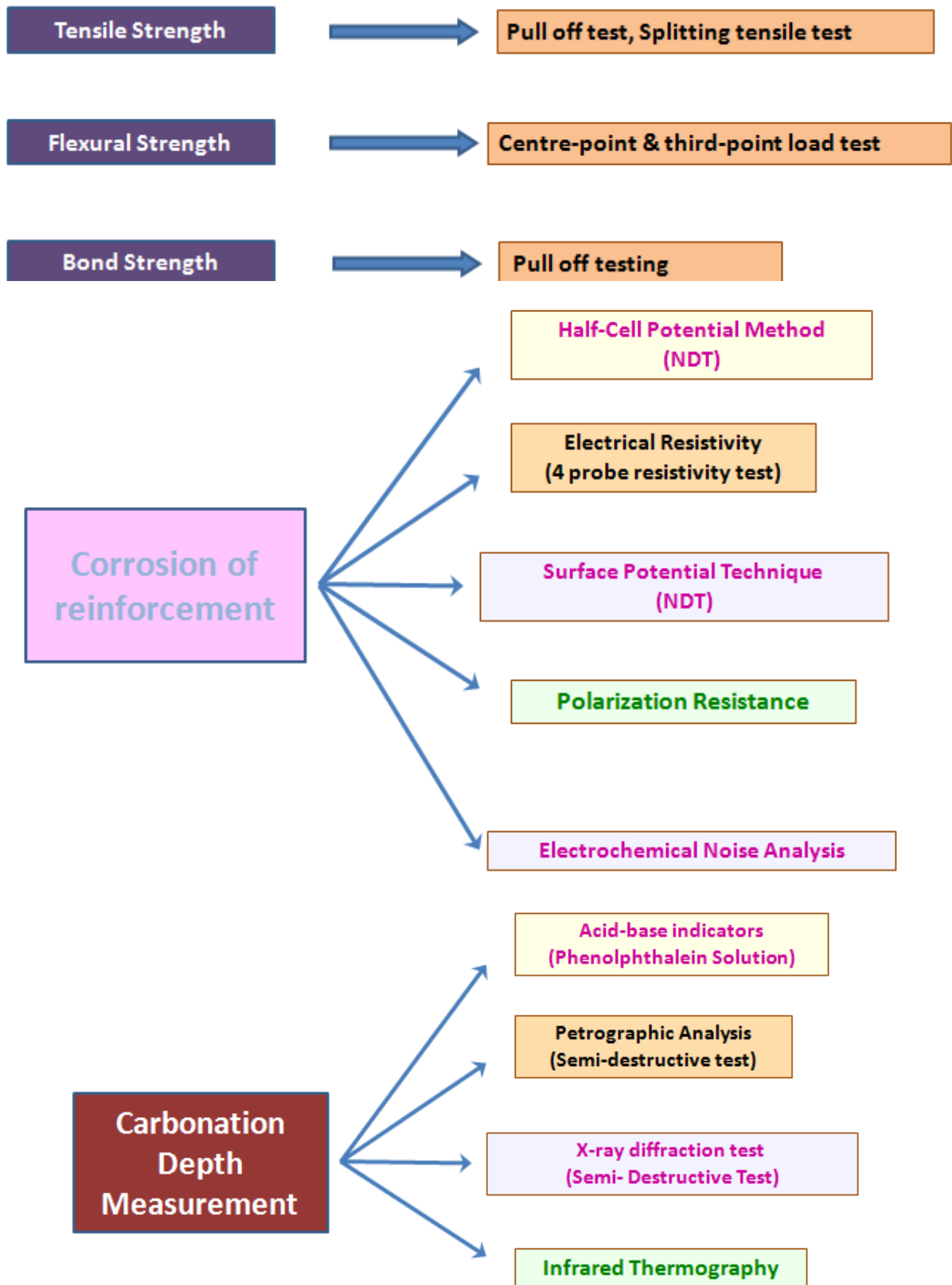

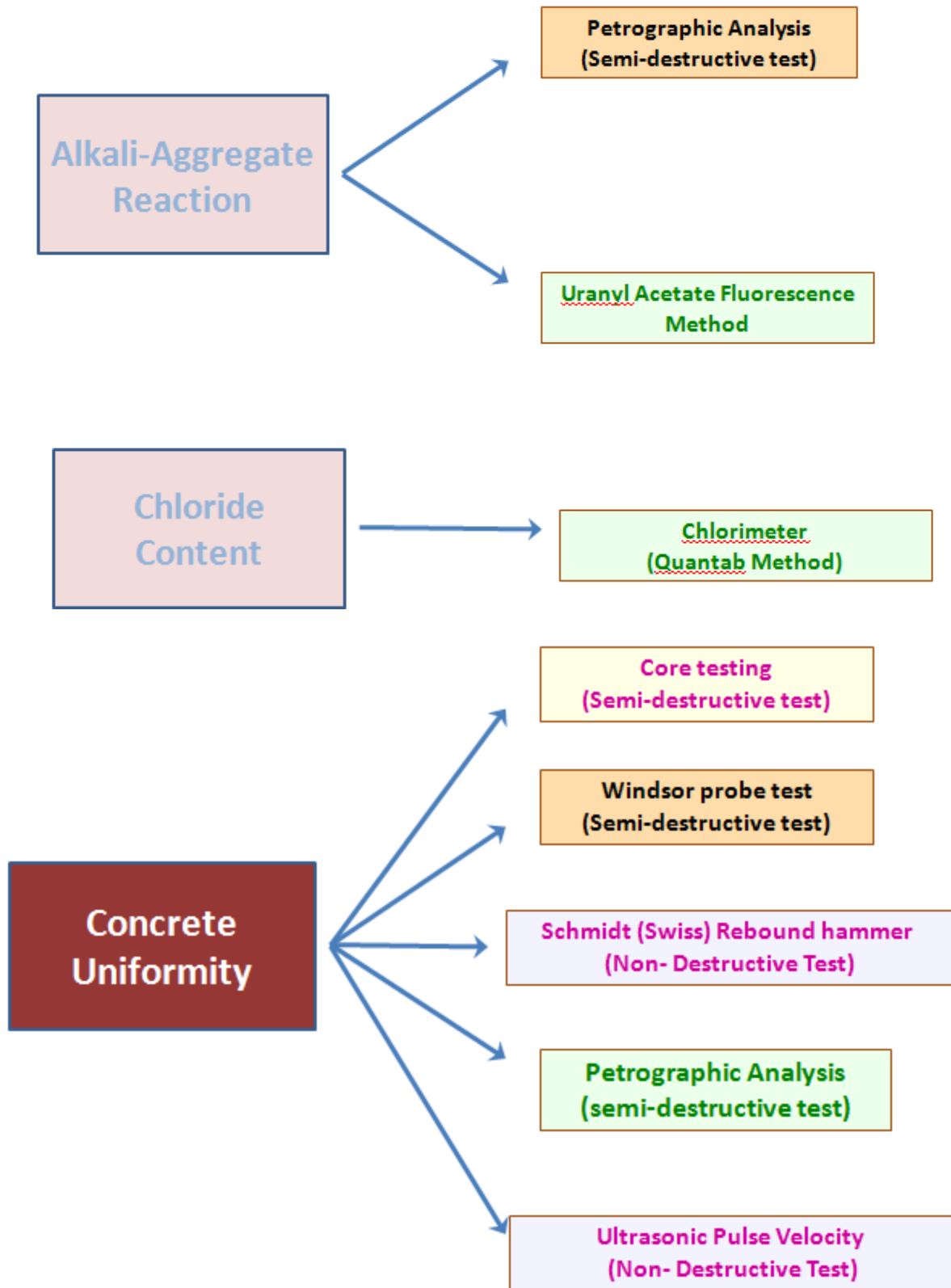

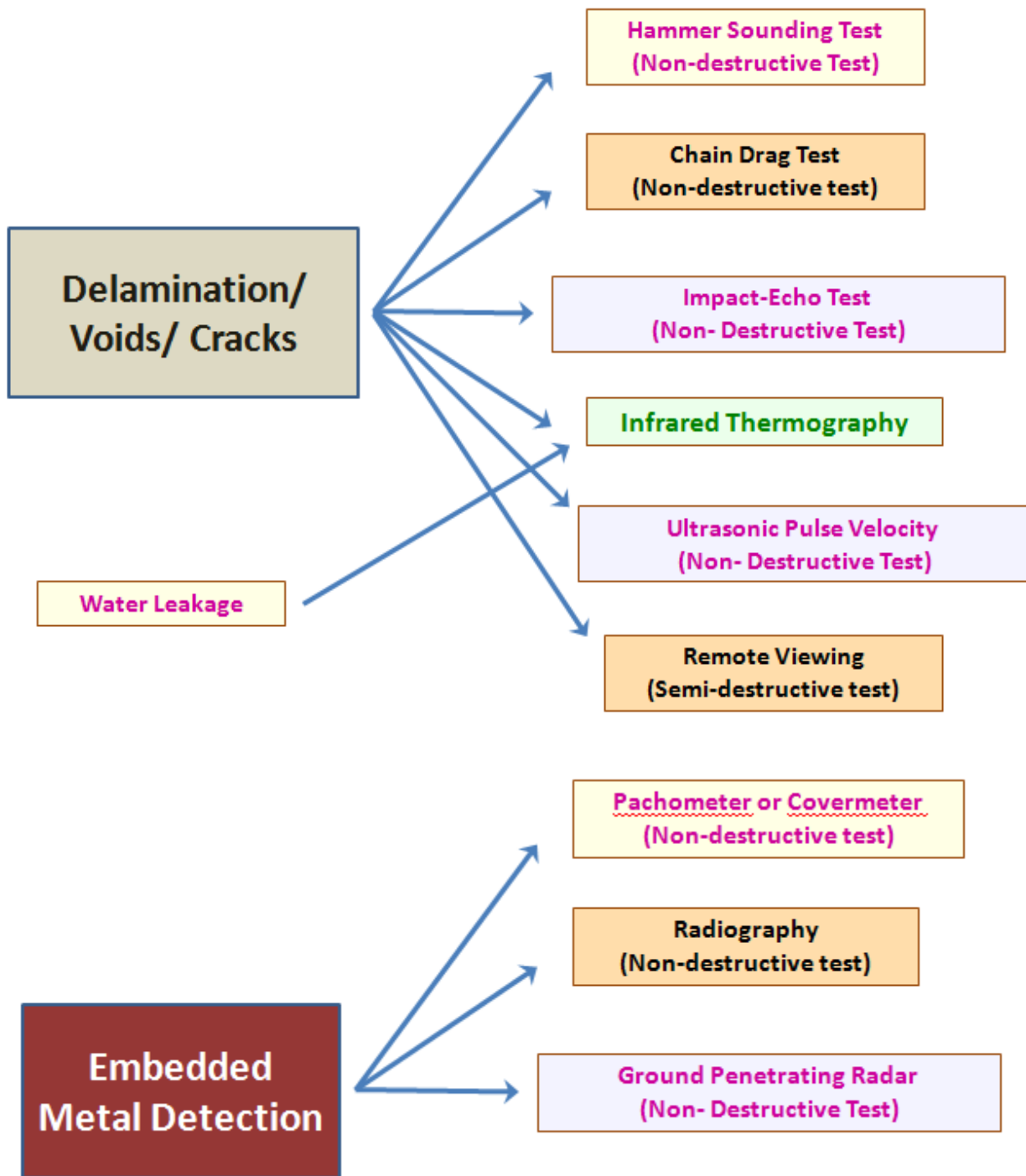

TOPIC 4 : STRENGTHENING OF STRUCTURES

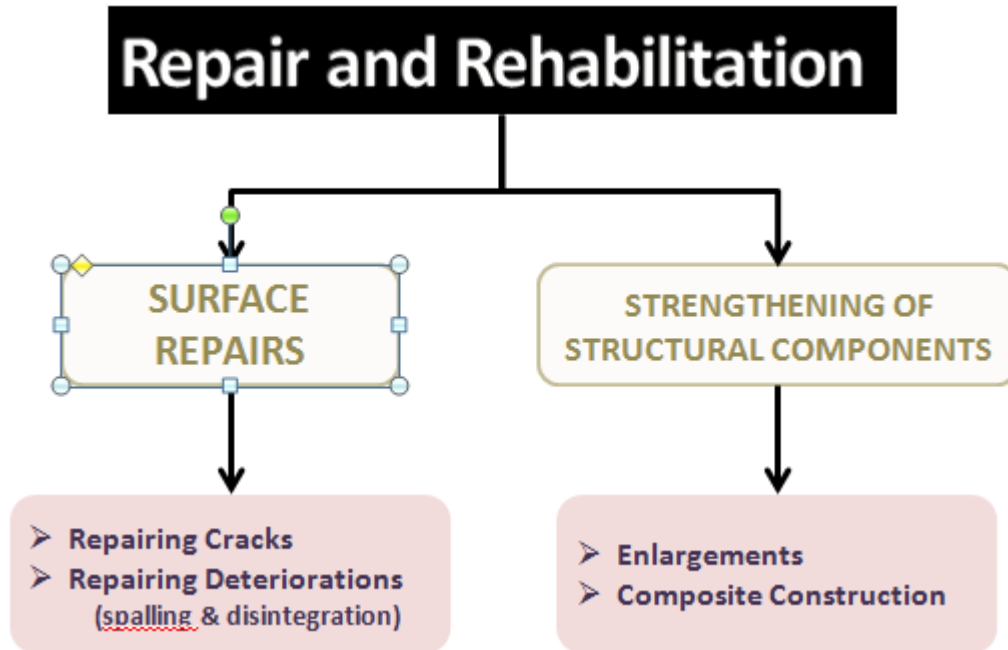

EVALUATION – ANALYSIS - STRATEGY

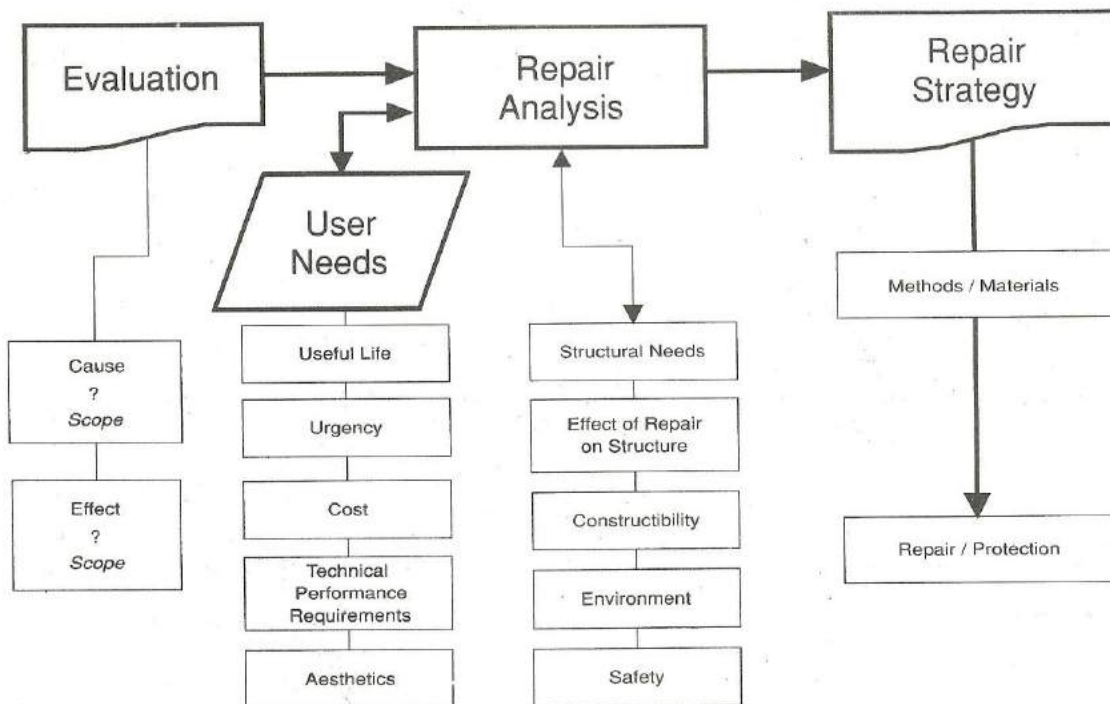

EVALUATION – ANALYSIS – STRATEGY

Example of Spalling due to Corrosion

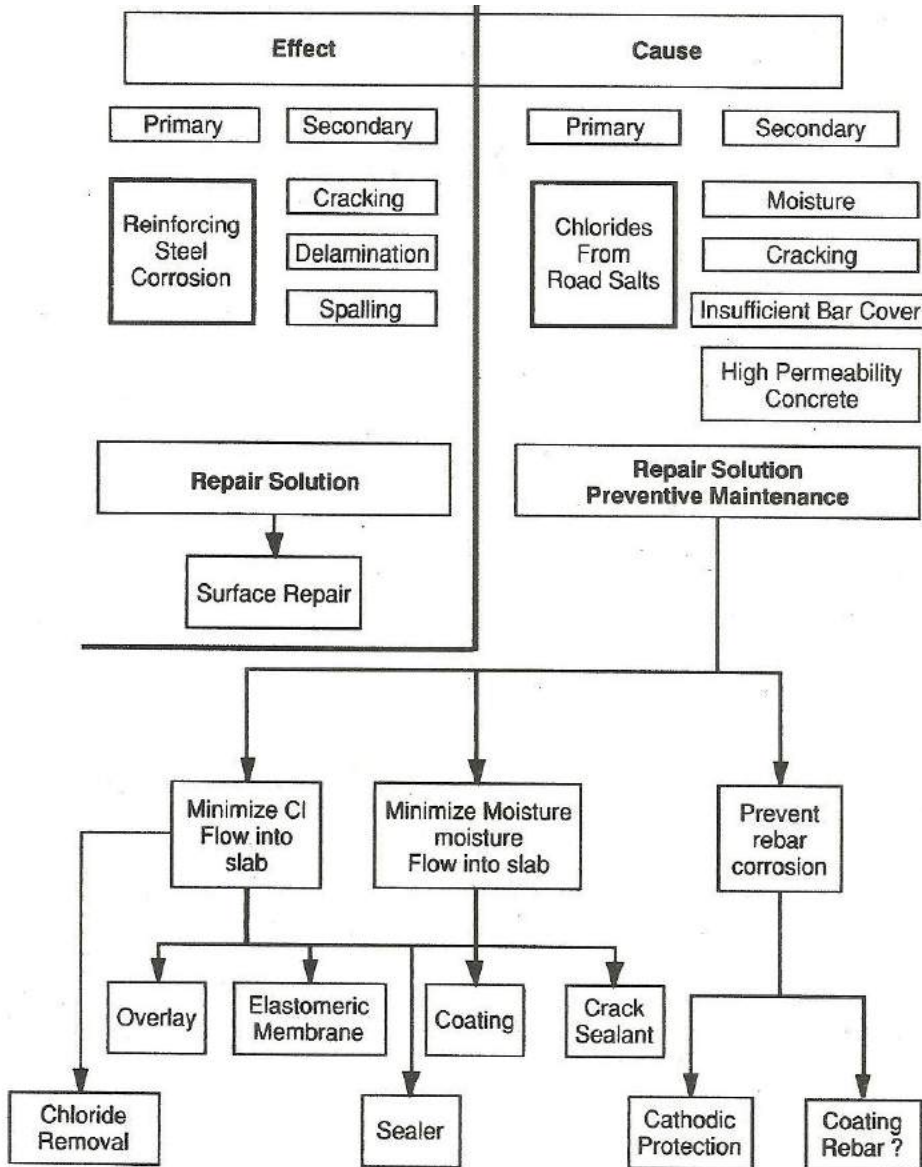

REPAIR MATERIALS

- MATERIAL REQUIREMENTS
- MATERIAL TYPES

MATERIAL SELECTION PROCESS

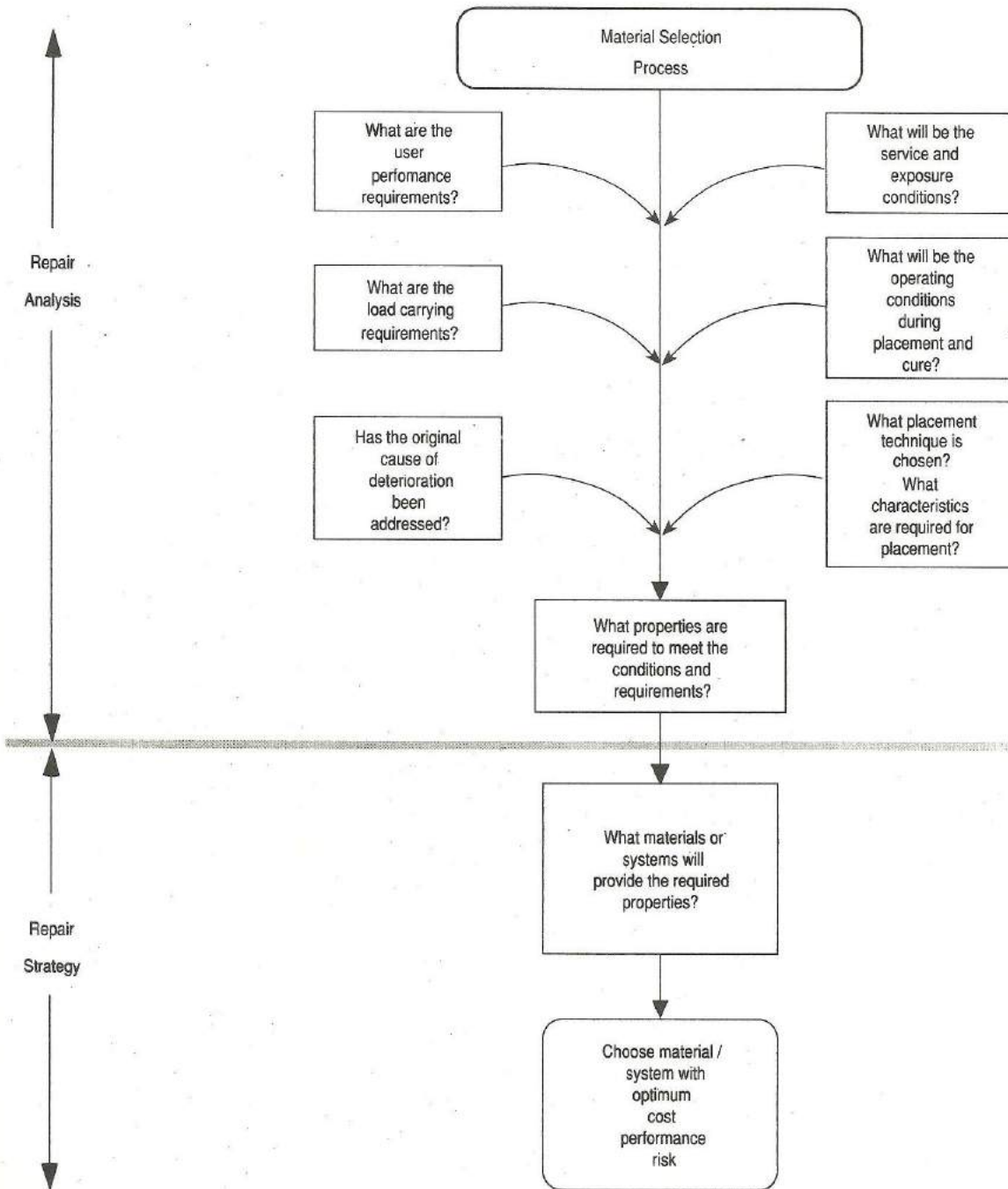

MATERIAL REQUIREMENTS

DESIRED PROPERTIES OF REPAIR MATERIALS

1. Engineered materials with high performance, high durability and low maintenance

- Composites

- Polymers
 - High performance concrete
2. **Materials must be easy to use, have high productivity and reduce construction cycle time**
 - High flow self-levelling concrete/mortar
 - Setting time controlling materials
 - Materials with wide applicability for varied substrate and environmental conditions
 3. **Safe for the workers and users, environment friendly: which do emanate toxics or irritating fumes during application or service**
 4. **Materials that do not add to the dead weight of the repaired component or the structure**

Selection of the Repair Material is guided by





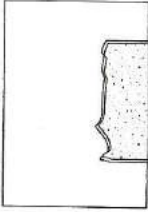

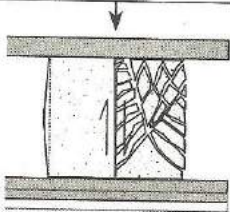
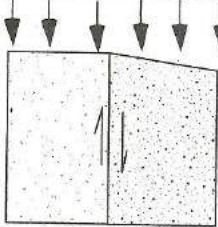
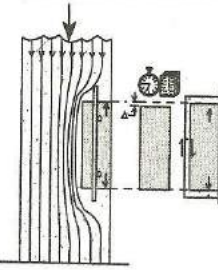
- Type of the structure
- Type of the service conditions and environment
- Nature of the deterioration
- Extent of the deterioration
- Appearance
- Economic considerations

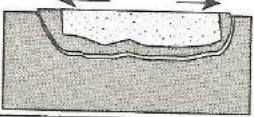

MATERIALS PROPERTIES AS PER REPAIR REQUIREMENTS

Load-Carrying Properties			
Goal (performance requirements)	Results if the wrong material is selected (undesirable response)	Look for these properties	Avoid these!
Bond to substrate	 <p>Loss of bond, delamination, detachment of repair from substrate</p>	Tensile bond, low internal stress	High internal stress caused by thermal incompatibility, drying shrinkage*

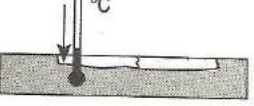

Load carrying as intended by the engineer		Does not carry loads as anticipated, overstressing either substrate or repair material	Equal modulus of elasticity with substrate	Low or high modulus of elasticity compared to substrate
		Carries loads initially, but over time, the repair relaxes under creep deformation.	Extremely low compression creep	High compression creep
		Drying shrinkage causes material to lose volume, reducing its ability to carry compressive loads.	Extremely low drying shrinkage*	Shrinkage*

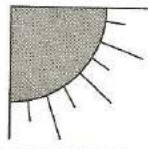
Service/Exposure Properties

Goal (performance requirements)	Results if the wrong material is selected (undesirable response)	Look for these properties	Avoid these!
Temperature changes  °C	 Shrinkage stresses cause cracking in repair material.	Equal thermal coefficient to substrate*	Unequal thermal coefficient to substrate
 °C	 Compressive stresses in substrate causing spalling.	Equal thermal coefficient to substrate*	Unequal thermal coefficient to substrate
Temperature changes in repair material during placement  °C	 Shrinkage stresses in repair material causing cracking.	Low exotherm during placement and cure	High exotherm during placement and cure
Atmospheric gases	Moisture conditions 	Low permeability at surface or internally, no cracks	High permeability, cracking in repair material

Chemical contact	Moisture conditions 	Corrode reinforcing steel.	Low permeability, at surface or internally no cracks	High permeability, cracking in repair material
		Disintegrate cement matrix.	Chemical resistance to substance at surface or internally	Lack of chemical resistance
UV exposure		Change in mechanical properties of repair material, changes to modulus of elasticity.	High UV resistance at surface	Low UV resistance
Moisture conditions, saturation	Freeze thaw cycles 	Dissintegration of cement matrix.	Low permeability at surface or internally	High permeability
Moisture conditions	Changes in internal moisture 	Shrinkage stresses, causing cracking.	Low permeability, low drying shrinkage*	High permeability, high drying shrinkage*

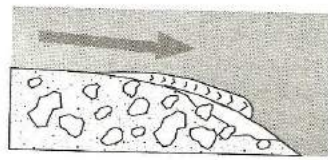
External Loads/Properties

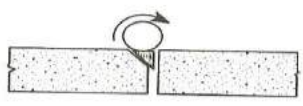
Goal (performance requirements)	Results if the wrong material is selected (undesirable response)	Look for these properties	Avoid these!	
Moving liquids	Erosion of surface  Erosion and abrasion of surfaces	High density	Low density	
		High compressive	Low compressive	
High tensile		Low tensile		
Moving liquids and suspended solids		High density	Low density	
		High compressive	Low compressive	
		High tensile	Low tensile	
	Vehicle wheels	 Abrasion damage to surface	High density, high compressive strength	Low density, low compressive strength
Impact		Edge spalling at joints	High compressive, tensile and bond strength, tensile anchorage into substrate	Low compressive, tensile and bond strength
		Spalling	High tensile strength, internal tensile reinforcement	Low tensile strength
			High compressive strength	Low compressive strength
		Loss of bond	High bond strength, tensile anchorage into substrate	Low bond strength

Constructibility & Appearance Properties

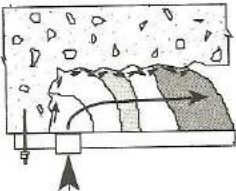
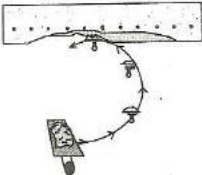
	Goal (performance requirements)	Look for these properties	Avoid these!
Constructibility	Turn-around time 	Rapid strength gain	Slow strength gain
	Flowability 	High slump	Low slump
		Small aggregate, fines, round shape	Large aggregate, angular shape, lack of fines
	Non sag 	High internal cohesion, high adhesive grip	Low internal cohesion, low adhesive grip
Forgiving "Murphy's Law"	Simple formulation, redundant	Complex formulation, dependent reactions	

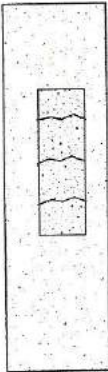
Goal (performance requirements)	Results if the wrong material is selected (undesirable response)	Look for these properties	Avoid these!
Appearance 		Cracking of surface from drying shrinkage*	High drying shrinkage*
		Cracking of surface in plastic stage	High exotherm
		Low surface water loss during placement	High surface water loss during placement
		Low drying shrinkage,* flexible surface membrane	
		Low exotherm	

Repair materials must have very low / zero drying shrinkage

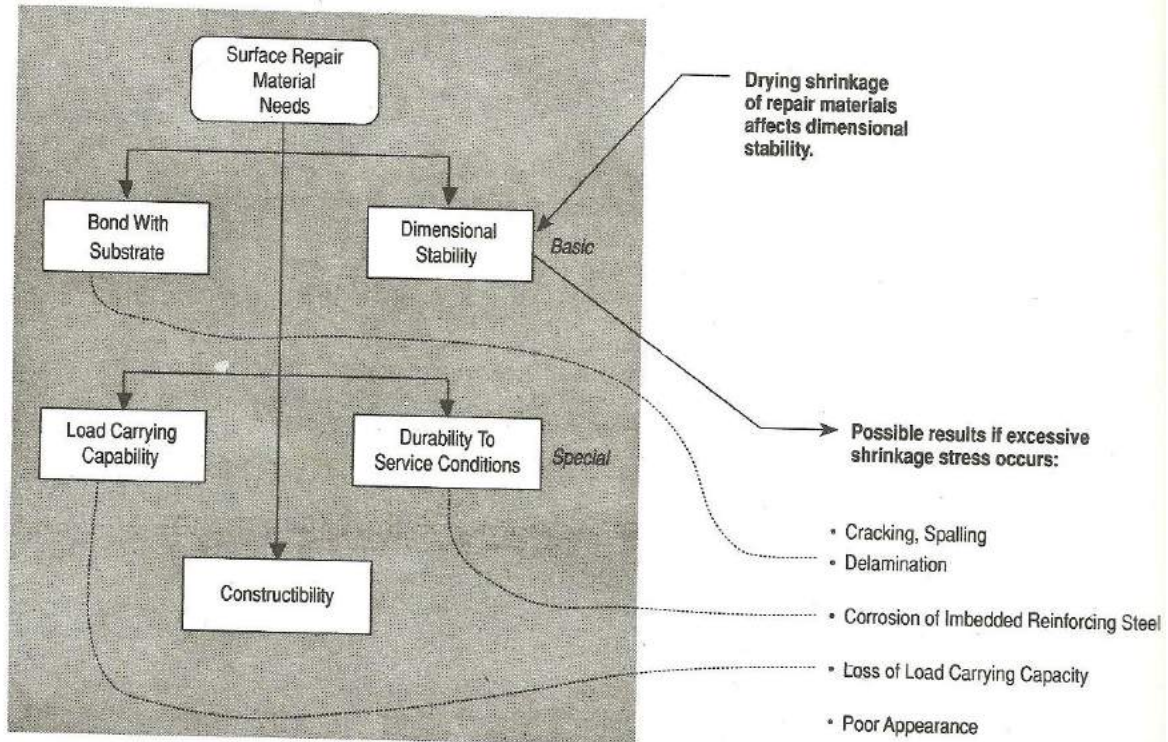

MATERIAL TYPES

GENERAL CLASSIFICATION OF REPAIR MATERIALS

1. Portland cement based materials
2. Polymer modified concrete
3. Resin based mixtures
4. Substitute materials/Recent products

PORTLAND CEMENT BASED MATERIALS

1. Portland cement mortar
2. Portland cement concrete

- The commonly used cement mortar or concrete with similar properties as the substrate.
- General observation is that problems such as shrinkage, cracking or even eventual failure of the repair work occurs.

POLYMER MODIFIED CONCRETE PRODUCTS

1. **Polymer modified cement**
2. **Polymer modified mortar**
3. **Polymer modified concrete**
 - also called Lat
 - ex Modified Concrete (LMC)
4. **Polymer and fibre-modified mortar**
5. **Polymer mortar**
6. **Polymer concrete (PC)**
7. **Polymer impregnated concrete (PIC)**
 - Polymer products have better durability under long-term exposure to UV radiation.
 - In cement mortar or concrete, the polymer can be used as a second binder to the mix.
 - Polymer mortars form matrix with cement in two-phase systems
 - In the cementitious water phase, fine polymer particles of 0.1 – 0.2 μm are dispersed
 - With cement, polymer particles join to form chain link reinforcement matrix increasing the tensile and flexural strength.
 - Matrix achieves greater plasticity and reduces shrinkage stress.

Polymer Concrete (PC) is formed by polymerizing a mixture of a monomer and aggregate (no other bonding material is present). Polymer concrete (PC) is a mixture of aggregates with a polymer as the sole binder. To minimize the amount of the expensive binder, it is very important to achieve the maximum possible dry-packed density of the aggregate.

Commercial products are available with a variety of formulations, some capable of hardening to 105 MPa within a few minutes without thermal treatment.

Due to good chemical resistance and high initial strength and modulus of elasticity, industrial use of PC has been mainly in overlays and repair jobs.

Thermal and creep characteristics of the material are usually not favourable for structural applications of PC.

Latex-Modified Concrete (LMC) is also known as Polymer Portland Cement Concrete. It is conventional concrete made by replacing part of mixing water with a latex. The materials and the production technology for concrete in LMC are the same as those used in normal portland

cement concrete except that latex, which is a colloidal suspension of polymer in water, is used as an admixture.

A latex generally contains about 50 % by weight of spherical and very small (0.01 to 1 μ m in diameter) polymer particles held in suspension in water by surface-active agents.

Earlier latexes were based on polyvinyl acetate or polyvinylidene chloride, but these are seldom used now because of the risk of corrosion of steel in concrete in the latter case, and low wet strengths in the former.

Elastomeric or rubberlike polymers based on styrenebutadiene and polyacrylate copolymers are more commonly used now.

The most impressive characteristics of LMC are its ability to bond strongly with old concrete, and to resist the entry of water and aggressive solutions.

It is believed that the polymer film lining the capillary pores and microcracks does an excellent job in impeding the fluid flow in LMC.

These characteristics have made the LMC a popular material for rehabilitation of deteriorated floors, pavements, and bridge decks.

Polymer-Impregnated Concrete (PIC) is produced by impregnating or infiltrating a hardened concrete with a monomer and subsequently polymerizing the monomer in-situ. The concept underlying PIC is to eliminate voids by filling with a polymer to improve strength and durability properties of concrete. Monomers such as methyl methacrylate (MMA) and styrene are commonly used for penetration of the hardened concrete because of their relatively low viscosity, high boiling point and low cost.

After penetration, the monomer has to be polymerized in situ. This is generally accomplished by using a monomer-catalyst mixture for penetration, and subsequently polymerizing the monomer by heating the concrete to 70 C with steam, hot water, or infrared heaters.

In PIC, by effectively sealing the microcracks and capillary pores, it is possible to produce a virtually impermeable product which gives an ultimate strength of the same order as that of PC.

PIC has been used for the production of high-strength precast products and for improving the durability of bridge deck surfaces.

RESIN BASED PRODUCTS

- 1. Resin-fibre composites**
- 2. Resin polymer mixture (for injection grouting)**

- Epoxy resin is combined with a hardener such as an amine or polyamide. Once combined, a molecular crust linkage takes place with very high bonding properties in a very short time.
- It is most useful to bond fresh concrete to the old concrete, filling up cracks, and for grouting and patchwork.

SUBSTITUTE MATERIALS/ RECENT PRODUCTS

1. Micro concrete

- Flowable and shrinkage free; only water required at site

2. Fibre Reinforced Cement Composites

- Improve tensile strength, toughness, abrasion resistance, energy absorbing capacity

3. FRP composite bars

- Effective in replacing defective or corroded reinforcement

4. High performance concrete mixes

TYPES OF SURFACE REPAIRS

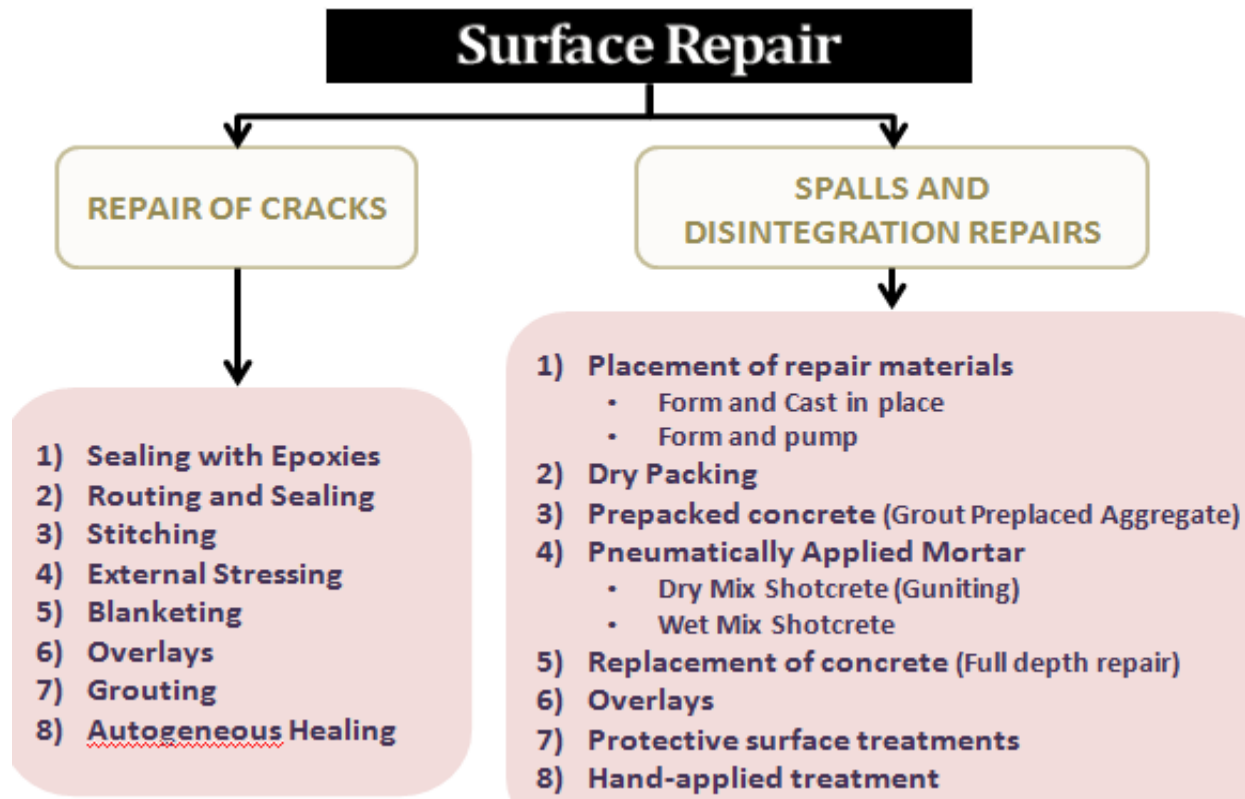

Crack Assessment

Check: Is the crack active or dormant?

Active crack is a growing crack. Dormant crack is a crack that has stopped growing

- 1) Placing a mark at the end of the crack.
- 2) A pin or a toothpick is lightly wedged into the crack and it falls out if there is any extension of the defect
- 3) A strip of notched tape works similarly : Movement is indicated by tearing of the tape
- 4) The device using a typical vernier caliper is the most satisfactory of all. Both extension and compression are indicated.
- 5) If more accurate readings are desired, extensometers can be used.
- 6) Where extreme accuracy is required resistance strain gauges can be glued across the crack

Crack Repair Techniques

- 1) Sealing with Epoxies
- 2) Routing and Sealing
- 3) Stitching
- 4) External Stressing
- 5) Blanketing
- 6) Grouting
- 7) Overlays
- 8) Autogeneous Healing

❖ **Sealing with Epoxies:** Cracks in concrete can be sealed by injecting epoxy with pressure into the cracks.

Steps involved in this method:

- (i) drill into the crack from the face of the concrete at several locations
- (ii) flush out dirt by injecting water or some solvent

- (iii) allow the surface to dry
- (iv) surface-seal the cracks between the injection points
- (v) inject the epoxy into the drilled holes until it flows through the other holes



Usually the epoxy is injected through holes of about $\frac{3}{4}$ inch in diameter and $\frac{3}{4}$ inch deep at 6 to 12 inches centres. Smaller spacing is used for finer cracks.

LIMITATIONS OF THE METHOD:

- 1) Unless the crack is dormant or the cause of cracking is removed and thereby the crack is made dormant, it will probably recur, possibly somewhere else in the structure.
- 2) Also, this technique is not applicable if the defects are actively leaking to the extent that they cannot be dried out, or where the cracks are numerous.

Routing and Sealing

The Method:

- (i) enlarge the cracks along their exposed surfaces,
- (ii) fill them up and seal them with a suitable material

Example: On road pavements, the cracks are commonly sealed by pouring hot tar over them.

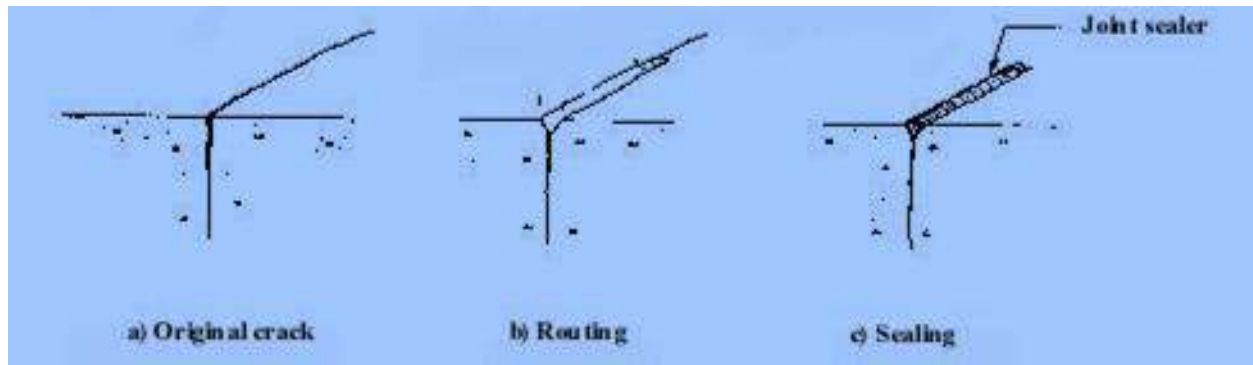

Advantages

- 1) Simplest and common method for sealing fine pattern cracks and large isolated cracks.
- 2) Inexpensive and expedient technique.
- 3) Water-tightness of the joint is not required.
- 4) Useful when appearance is not important.

Limitations

- 1) The cracks must be dormant.
- 2) For leaking cracks the method must be applied on the pressure face so that the water-aggressive agents cannot penetrate the interior of the concrete.
- 3) Carelessness can cause side-effects such as swelling, chemical attack or corrosion of the rebars

Stitching

The tensile strength of a cracked concrete section can be restored by stitching in a manner similar to sewing a cloth, but using iron or steel dogs. Dogs of variable length are placed at varied locations and orientation so that the tension across the crack is distributed throughout rather than being concentrated on a single plane. The holes drilled in the concrete to receive the dogs must be finally filled with non-shrink grout.

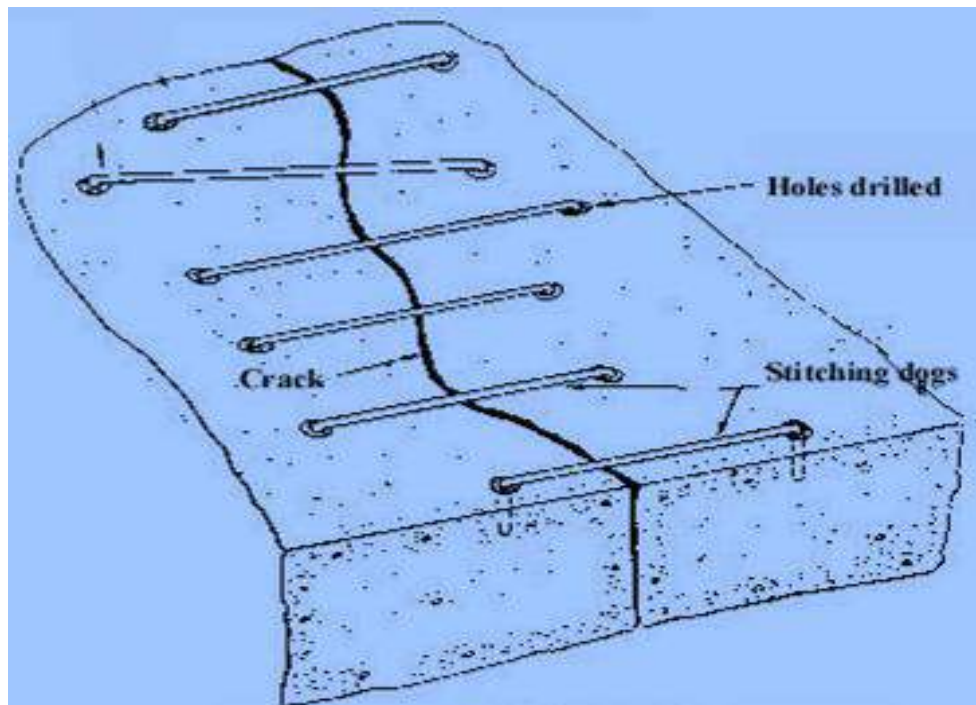

CAUTIONS IN USING THIS TECHNIQUE:

- 1) Over strengthening of the crack joint tends to stiffen the structure locally.
- 2) Stitching the crack will tend to migrate the crack elsewhere in the structure. Strengthening of the adjacent areas of the crack is necessary.
- 3) In places where water ingression is likely the crack must be sealed in addition to stitching. Suitable overlay must also be applied to prevent corrosion of the stitches.
- 4) At the ends of the cracks, where the stress concentration is more, the spacing between the stitching dogs must be reduced. The stress concentrations at each end of the crack can also be relieved by drilling suitable holes or marking the ends rounded.
- 5) Whenever possible both sides of the cracks must be stitched to prevent bending of the dogs due to the movement of the structure.

The dogs are thin and long and so cannot take much of compressive force. These must be stiffened and strengthened by encasing them in an overlay.

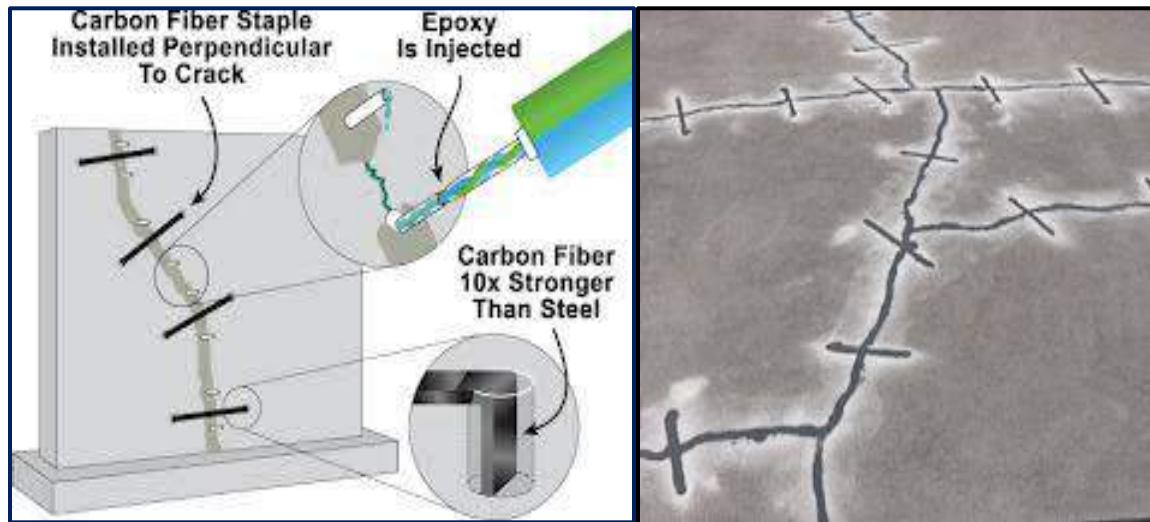

External Stressing

- Involves counteracting the tensile stress that causes cracking by inducing a compression force.
- This compression force not only overcomes tension but also provides a residual compression.
- The compressive force is applied by using pressing wires or rods.

The principle is similar to stitching except that the stitches are pre-tensioned.

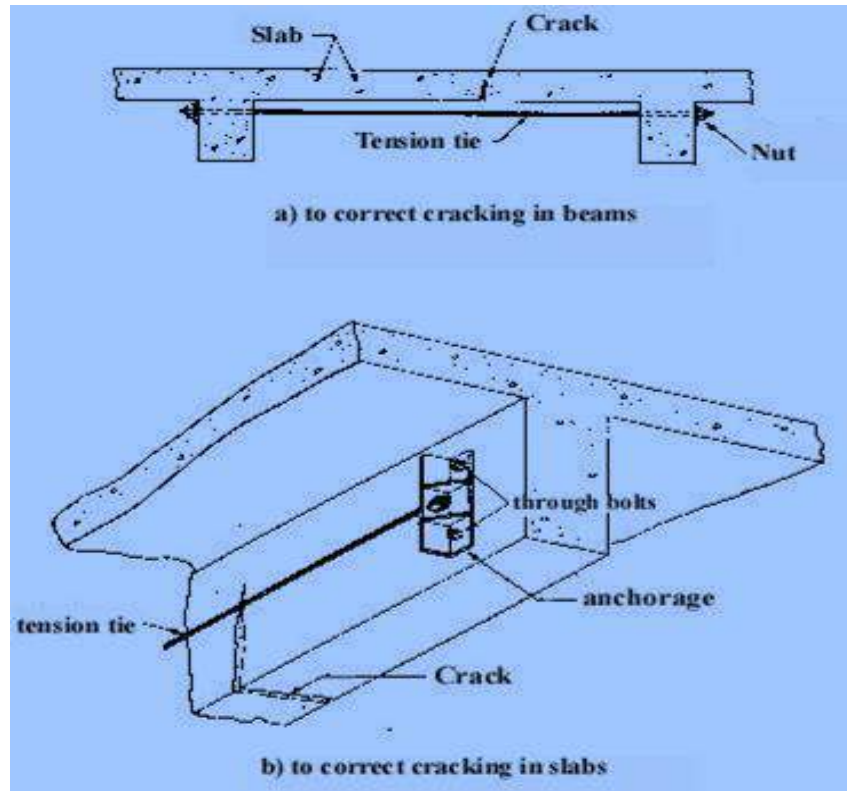

Blanketing: Technique is similar to routing and sealing but is used on a large scale for sealing both active and dormant cracks.

- Preparing the chase is the first step
- Usually the chase is cut square or trapezoidal.
- The bottom should be chipped as smooth to facilitate breaking the bond between sealant and concrete
- The sides of the chase should be prepared to provide a good bond with the sealant material

The first consideration in the selection of sealant materials is the amount of movement anticipated and the extremes of temperature at which such movements will occur. Depending on the need different types of sealants are used

1) Elastic sealants

2) Mastic sealants

3) Mortar-plugged joints

4) Crimped water bar

Elastic sealants: At a crack or a joint an elastic sealant is used. The sealant material is one which returns to its original shape when the externally induced stress is removed. When the crack width is small, a strip sealant is sufficient.

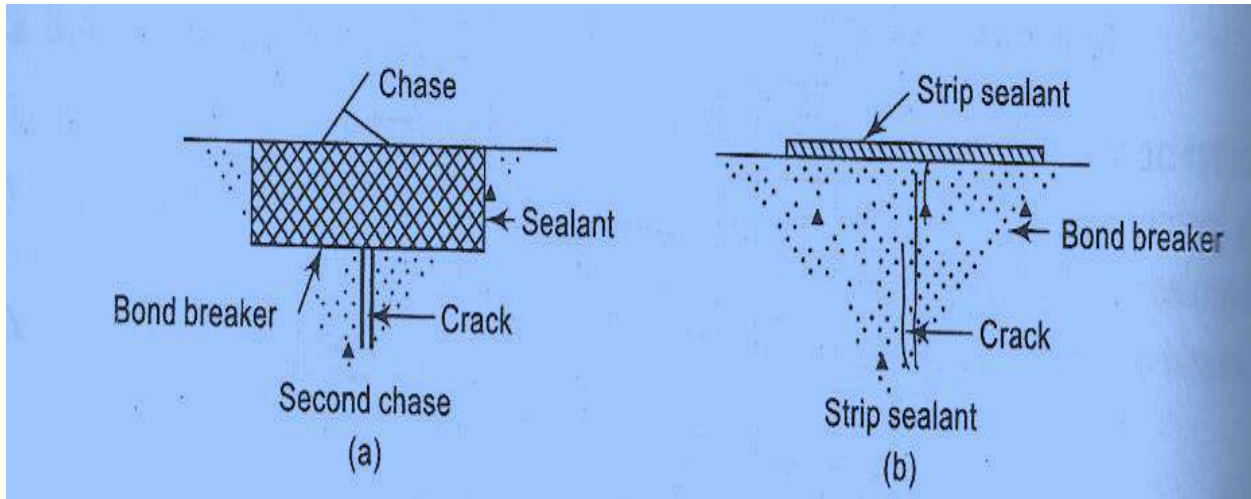

Mastic-filled Joint: The sealant is mastic rather than a compound with elastic properties. The sealant is bonded to the bottom as well as to the sides of the chase. The bond breaker at the bottom is omitted. This sealant type is used when anticipated movements are small. There is risk of sealant tearing at the bottom in this type.

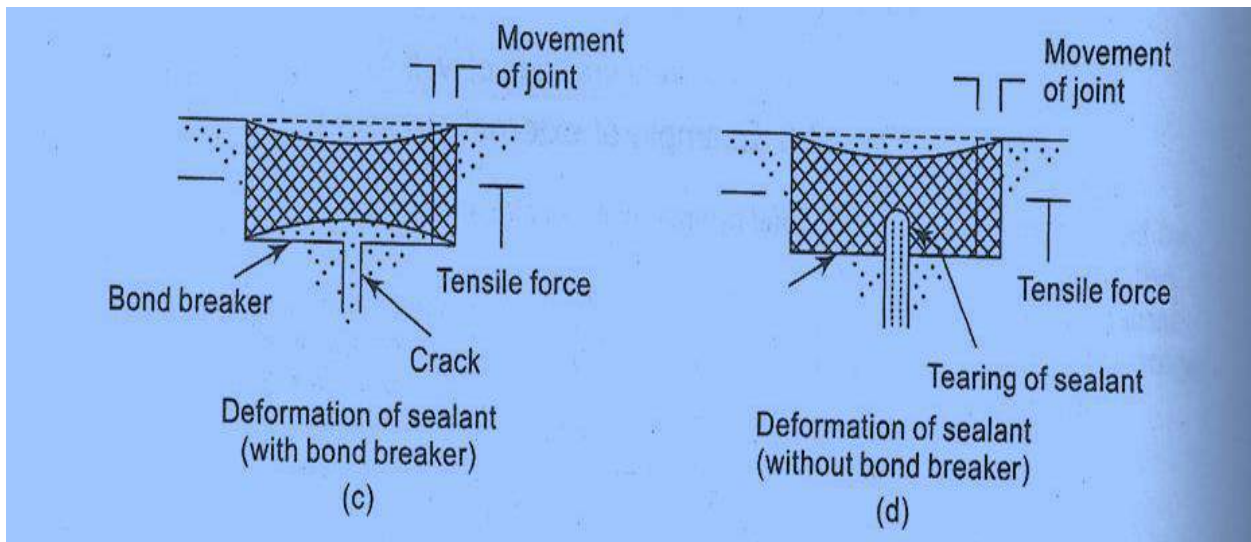

Mortar-plugged joint: The chase is cut in the form of a trapezoid to and filled with mortar. The internal stresses in the mortar due to external and internal pressures are shown in Fig (a) and (b). Fig (c) shows the pressure relieving groove on the surface of the plugged mortar and cutting and closing the mouth tip of the crack with quick set mortar. Fig (d) shows weep pipes to drain excess fluids and also to relieve pressure.

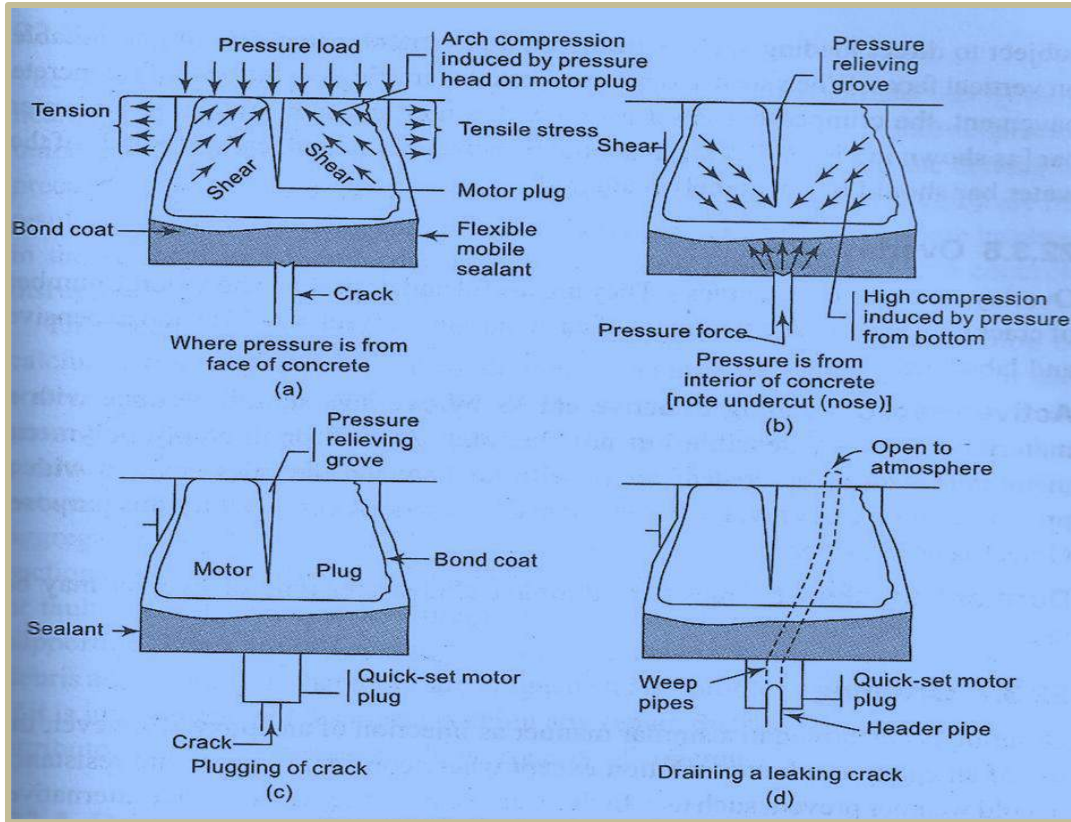

Crimped water bar

A crimped water bar arrangement at locations where

- (a) the bar is not subjected to direct loads such as the traffic loads.
- (b) the bar is subjected to direct loads such as the traffic loads.

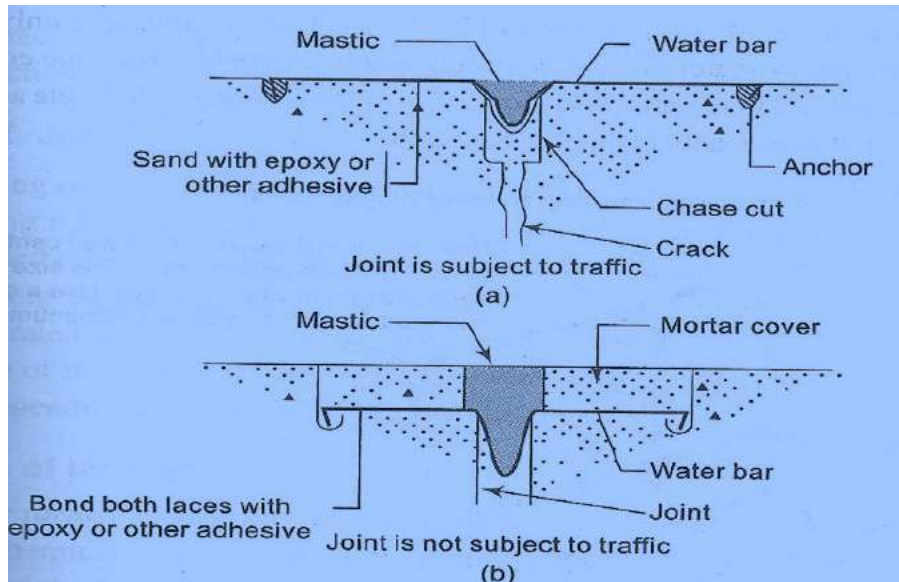

Grouting

The technique is similar to the injection of an epoxy. Grout is a mortar paste, sometimes mixed with adhesives to increase bonding properties.

The steps involved in grouting are:

- cleaning the concrete along the crack
- installing built-up seats at intervals along the crack
- sealing the crack between the seats with a cement paint or grout
- flushing the crack to clean it and test the seal, and then allow it to dry
- then grouting the whole crack by forceful injection of the grout mix

Allow the grout to set for some duration of time before reuse.



Overlays: Overlays are used to seal cracks when a large number of cracks are present and treatment of each individual crack would be too expensive and laborious.

For Active Cracks: Sealing of active cracks by overlays should be done with a material which is extensible but not flexible. A two or three –ply polymeric membrane with a top coat of tar or with tar between the plies covered with a protective course of gravel, concrete or brick, functions very well for this purpose. Gravel is used for roofs.

For Dormant Cracks almost any type of overlay can be used.

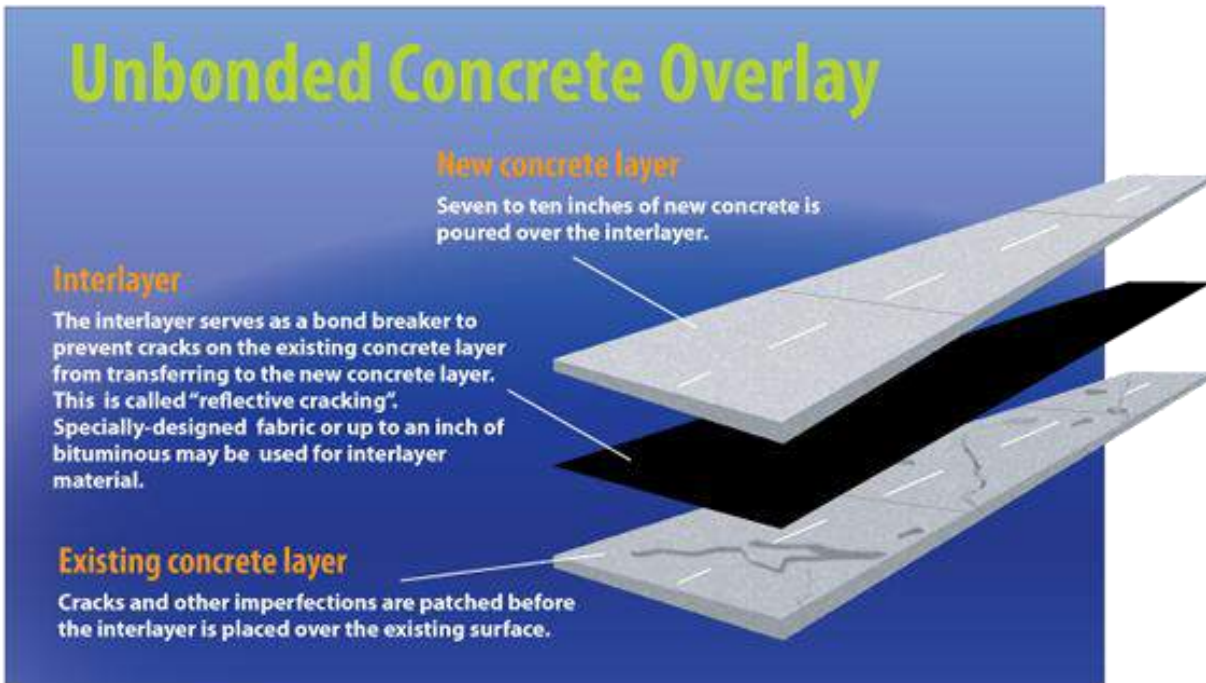

Autogenous Healing: The inherent ability of concrete to heal cracks within itself is termed 'autogenous healing'.

This is used for sealing dormant cracks such as in the repair of precast units cracked during handling, rectifying cracks developed during the driving of precast piling, sealing of cracks in water tanks, and sealing of cracks which are the result of temporary loading conditions. This property also provides some increase in the strength of concrete damaged by vibration during setting and concrete disrupted due to freezing and thawing.

The mechanism by which autogenous healing occurs is the carbonation of calcium oxide and calcium hydroxide in the cement paste by CO_2 in the air and water. The resulting CaCO_3 and $\text{Ca}(\text{OH})$ crystals precipitate, accumulate, and grow through and out from the cracks. The crystals interlace and twine, thus producing a mechanical bonding effect which is supplemented by chemical bonding between adjacent crystals, and between crystals and the surfaces of the paste and aggregates. As a result some of the tensile strength is restored across the cracked section and the crack is sealed.

Dormant cracks such as those caused by shrinkage or fault in construction such as premature removal of forms or settlement of sills supporting shores are self-sealing. This is because cracks get clogged by dirt and debris and the result is that these are plugged and the problems of leakage specially if it is intermittent will disappear without any repair. Such self-healing can also be attributed to the autogenous healing property of concrete.

Repair of Spalling and Disintegration

- 1) Placement of repair material
 - Form and Cast in place
 - Form and pump
- 2) Dry Packing
- 3) Prepacked concrete (Grout Preplaced Aggregate)
- 4) Pneumatically Applied Mortar
 - Dry Mix Shotcrete (Guniting)
 - Wet Mix Shotcrete
- 5) Replacement of concrete (Full depth repair)
- 6) Overlays
- 7) Protective surface treatments
- 8) Hand-applied treatment

❖ Placement of Repair Material : (A) Form and Cast-in-Place

One of the most common methods of surface repair of vertical and, in some cases, overhead locations is the placement of formwork and casting of repair material into the prepared cavity.

Formwork facilitates the use of many different repair materials, selected on the basis of in-place performance vs. constructibility. The repair material must be of low shrinkage and provide the necessary flowability.

Placement of repair materials follows normal placement practice. Rodding or internal vibration is necessary to remove air and provide intimate contact with the existing concrete substrata

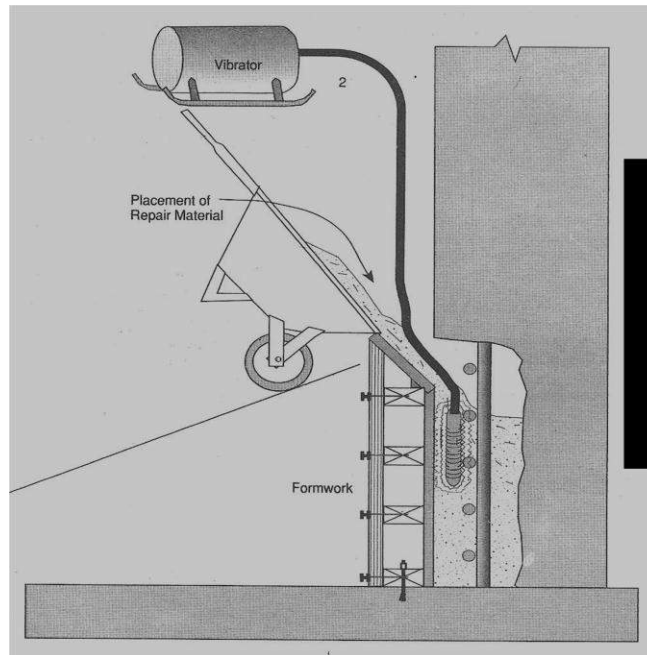

❖ **Placement of Repair Material : (B) Form and Pump**

The form and pump repair method is a two-step process of constructing formwork and pumping repair material into the cavity confined by formwork and existing concrete.

The form and pump technique allows the use of many different repair materials. The necessary requirement for material selection is pumpability.

Various pumps are used, depending upon the mix design (particularly the aggregate size). Prior to construction of formwork, any surfaces that may cause air to become trapped during the pumping process must be trimmed, or vent tubes installed.

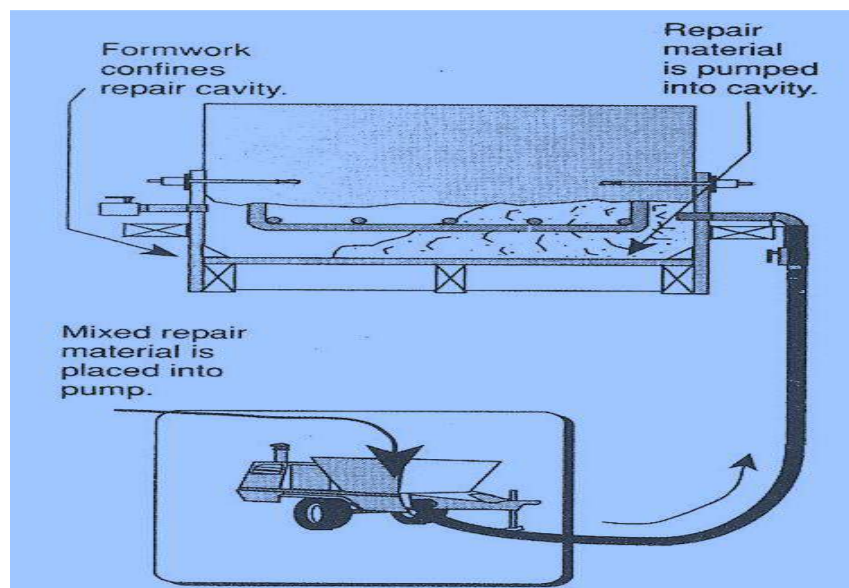

Repair materials are mixed and pumped into the confined cavity. The sequence of pumping is from low points to high points and when performed overhead, from one extremity to the other. Large areas may require bulk-heading to separate placements into manageable areas.

When the cavity is full, pump pressure is exerted on the form, causing the repair material to consolidate and make intimate contact, and effect bonding with existing concrete surfaces.

Advantages of Form and Pump Technique

Form and pump technique offers many advantages to alternative techniques, such as shotcrete, hand-placement, and preplaced aggregate. Advantages include:

- The use of almost any repair material from fine grained mortars to coarse aggregate concrete, including polymers and hydraulic cement materials.
- Placement is not limited by depth of repair or by size or density of exposed reinforcement.
- Repair materials are premixed and placed to provide a uniform cross section without segregation or intermediate bond lines.
- The process does not depend on fighting the forces of gravity; all materials are supported by formwork during the placement and curing process.
- The pressurization process consolidates the repair material, providing for full encapsulation of exposed reinforcing steel.
- The formwork protects the repair material during the curing process.
- The process is less subject to individual operator error.

Quality assurance of the in-place repair is easier to provide.

❖ **Dry Packing:** Dry packing is a method of placing zero-slump, or near zero-slump, mortar or concrete, by ramming, into surface cavities. Dry packing techniques can be used in all locations: overhead, vertical and flat. Best applications are generally small cavities such as tie holes, small areas of surface honeycomb or rib bottoms (shown in illustration).

Each dry pack mortar repair is placed in layers. Compaction is achieved with a hardwood stick to prevent polishing of the surface. Curing is accomplished with a continuous 7-day moist cure.

The consistency of dry pack mortar must be such that it can be molded into a ball without excessive bleeding. Compaction densifies the mortar and provides the necessary intimate contact with the existing concrete for achieving bond.

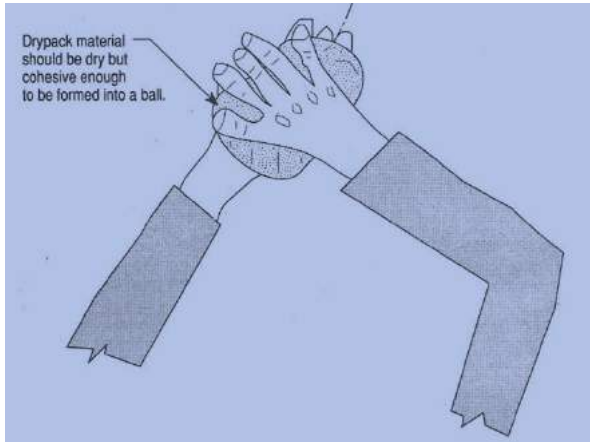
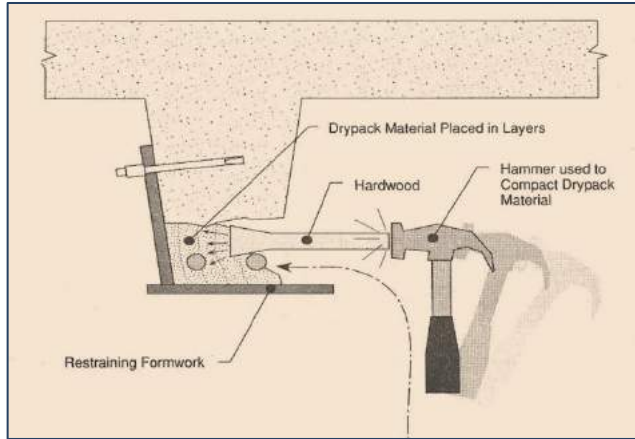

❖ Prepacked concrete (Grout Preplaced Aggregate)

Grouted preplaced aggregate is a two-step process. The first step involves aggregate placement into the cavity during the erection of formwork. The aggregate is gap-graded and washed of all fines. The void ratio of the cavity after the aggregate is placed, ranges from 40% to 50%.

The second step involves pumping a highly flowable grout through the formwork and into the preplaced aggregate. Grout flow fills the lower voids and progressively fills the cavity, eventually flowing to higher elevation ports.

After grout flows from adjacent ports, the grout hose is disconnected from the port being pumped, and reconnected to the port showing new flow. The process continues until the cavity is full and pressurized

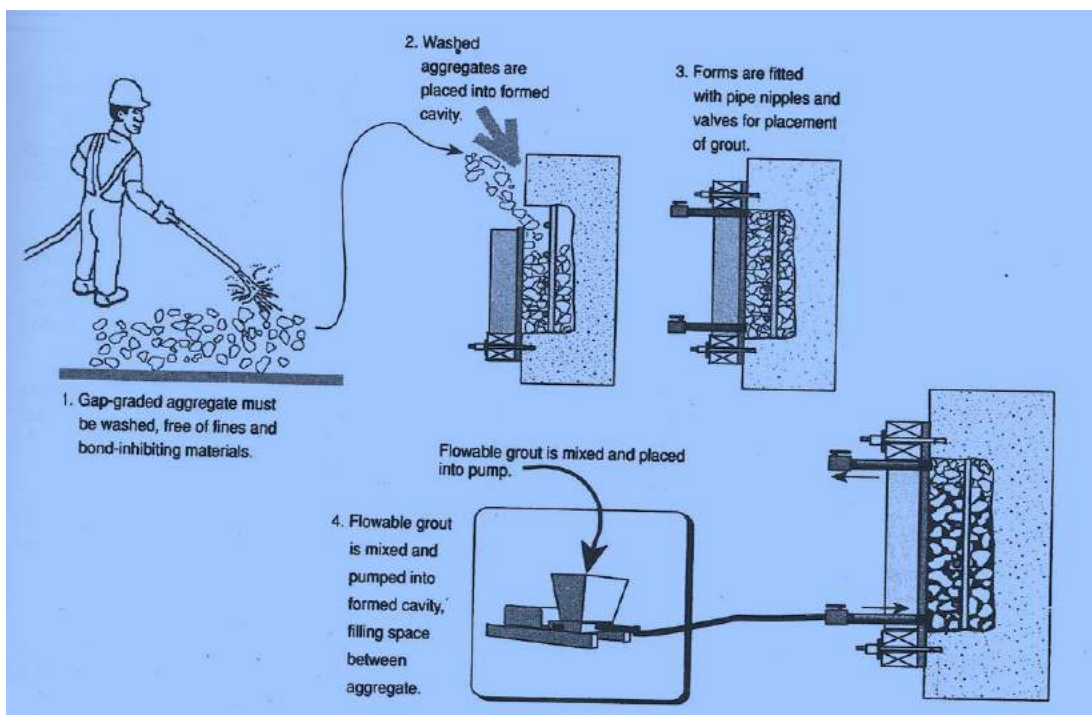

The grout flow makes contact with the prepared substrate as the cavity is filled, providing intimate contact and bonding. A unique advantage of this method is the low drying shrinkage of the repair material due to the point-to-point contact between the coarse aggregates. The aggregate contact restricts the volume change of the cement grout as drying shrinkage occurs. Various grouts can be used for the grouting process. Most popular are Portland cement- based grouts and, for special applications, epoxy resins.

- ❖ **PNEUMATICALLY APPLIED MORTAR:** Mortar or concrete is conveyed through a hose and pneumatically projected at high velocity onto a surface to be freshly constructed or to be repaired.

There are two procedures of placing concrete pneumatically:

- A) Guniting or Dry Mix Shotcrete
- B) Wet Mix Shotcrete

- ❖ **Dry Mix Shotcrete or Guniting:** Dry mix shotcrete is a method that involves the premixing of binder and aggregates, which are then fed into a special mechanical feeder metering the premixed materials into a hose. The material is conveyed through the hose with compressed air to a nozzle which is outfitted with a water ring where additional water is mixed with the binder and aggregates. The mix is jetted from the nozzle at high velocity onto the prepared concrete surfaces.

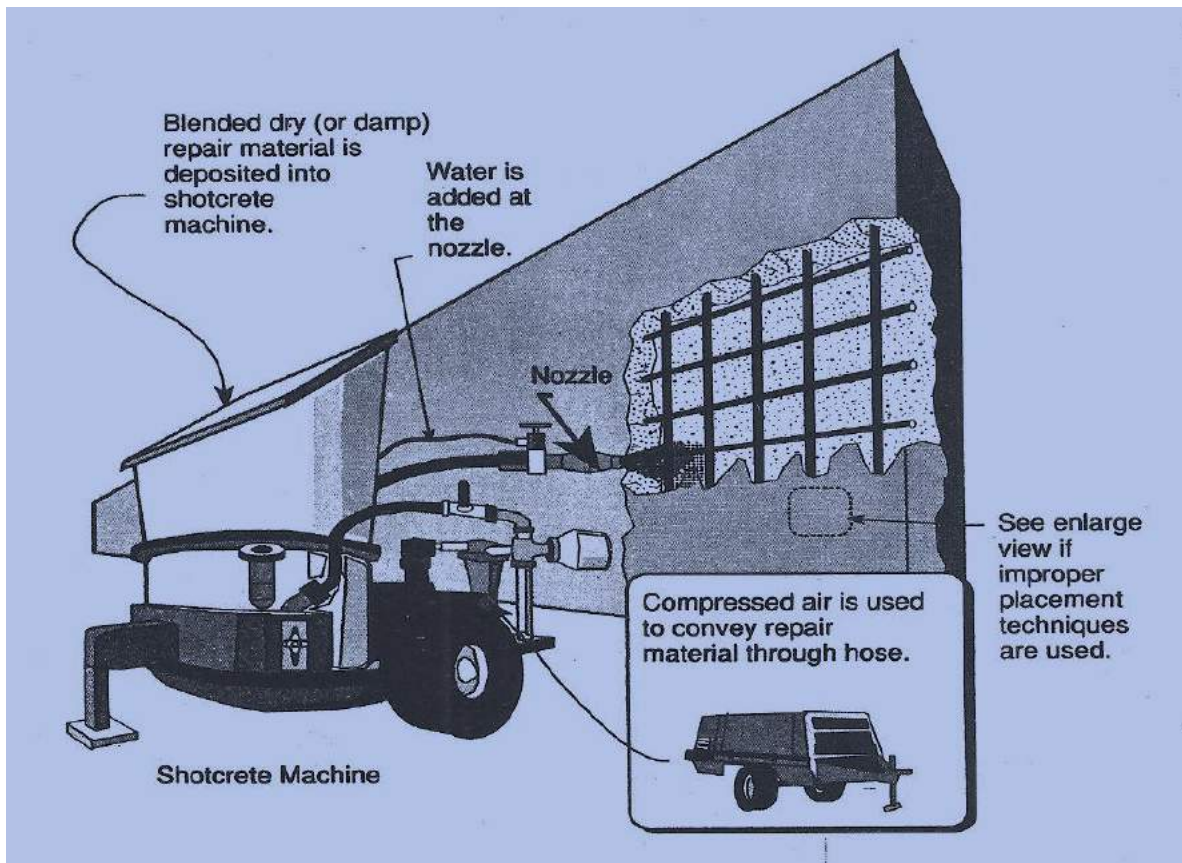

The process demands expertise and responsibility of the worker (nozzle operating man). He has much better control over the w/c ratio than compared to the wet mix process. The process varies, depending upon the necessary thickness and orientation. Where the repair is thick, the process may involve the placement of multiple layers. Excessive thickness of individual layers may result in sloughing off.

The use of special admixtures has helped improve the workability and performance of shotcrete. Silica fume is a good property enhancer. It improves the concrete's adhesive and cohesive properties, along with its ability to provide for larger placement thicknesses. The resulting hardened properties include increased flexural and compressive strengths and increased durability to freeze-thaw and chemical attack.

The use of chemical accelerators should be avoided where not absolutely necessary. Accelerators have been found to cause increased drying shrinkage.

Additives for Dry Mix Shotcrete

Additives	Benefit	Comments
Silica Fume	<ul style="list-style-type: none"> • Increased thickness • Increased density • Increased freeze-thaw resistance • Increased chemical resistance • Reduced rebound • Increased adhesion • Increased flexural and compressive strength 	
Accelerators	<ul style="list-style-type: none"> • Increase/buildup of layers • Reduced initial set time • Increase early strength gain 	<ul style="list-style-type: none"> • Increased drying shrinkage • Reduced shotcrete strength with age • Not necessary if silica fume is used
Steel Fiber	<ul style="list-style-type: none"> • Elimination of shadows and voids which are created with conventional reinforcement • Improved impact resistance. 	
Polypropylene Fibers	<ul style="list-style-type: none"> • Reduced plastic shrinkage cracking 	
Latex	<ul style="list-style-type: none"> • Improved flexural, tensile bond strengths • Increased resistance to freeze-thaw and chemical attack. 	<ul style="list-style-type: none"> • Latex hardened film may occur between layers, causing delamination.

❖ **Wet Mix Shotcrete:** Wet mix shotcrete is a method that involves premixing of all ingredients (except accelerators) including binder, aggregates, admixtures, and mixing water. The premixed repair materials are deposited into a pump or pressure vessel which transports the materials to an exit nozzle, where compressed air is introduced. The repair material is propelled onto the substrate with compressed air. Admixtures can be used to enhance the shotcrete material. Silica fume and fibers are commonly used to enhance durability. Air entrainment is required for freeze-thaw resistance.

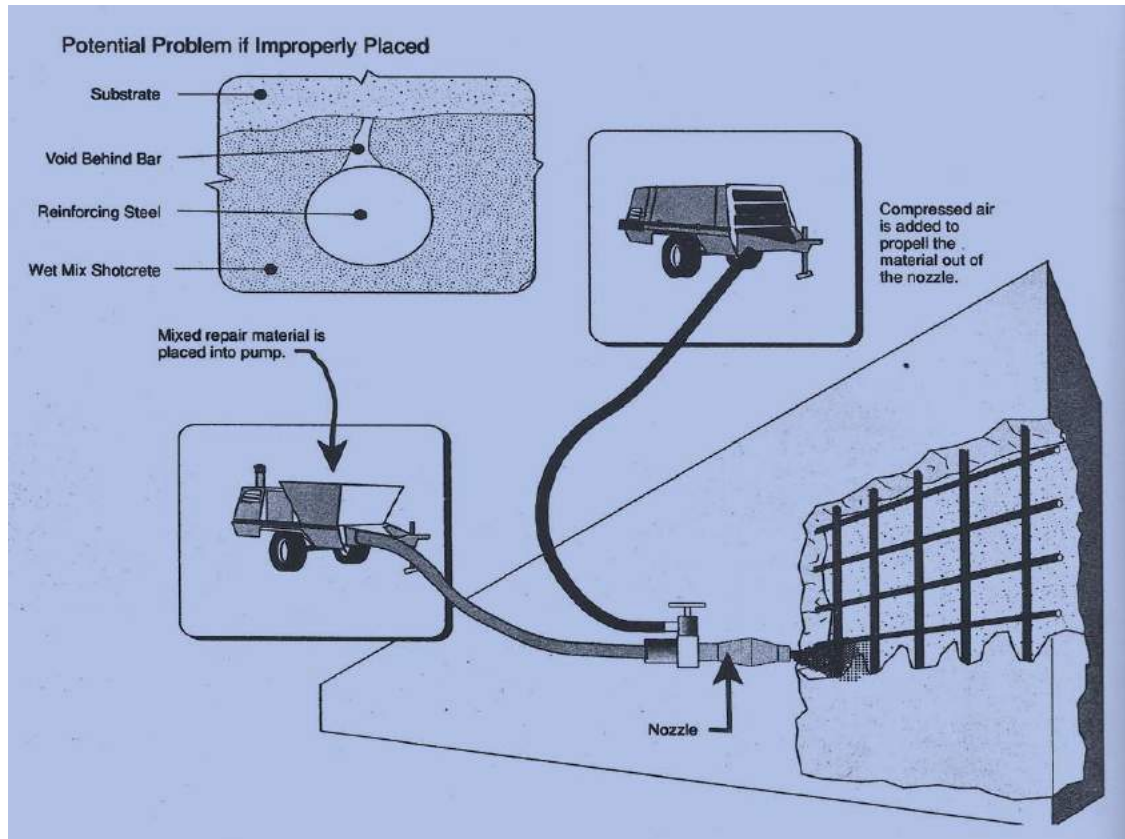

Typical Problems Associated with Shotcrete Repairs

- Presence of voids due to encapsulated rebound; common when multiple layers are used or when heavy reinforcing is encountered.
- Shrinkage cracking caused by high cement content, improper curing, or excessive water content.

- ❖ **Replacement of Concrete: Full depth repair:** In certain situations, surface repair may be better served by full depth repair. For example, when concrete surfaces have extensive surface damage, it may be more economical and provide for longer lasting repairs if the affected part of the member is removed and reconstructed. Consideration should be given to minimizing the restrained perimeter drying shrinkage. After placement of the new concrete, drying shrinkage results, causing tension within the newly reconstructed member and at the bond between new and old. In most cases, if tension stresses are not addressed, unplanned cracking may result. Low shrinkage concrete mixes should be used to reduce shrinkage stresses.

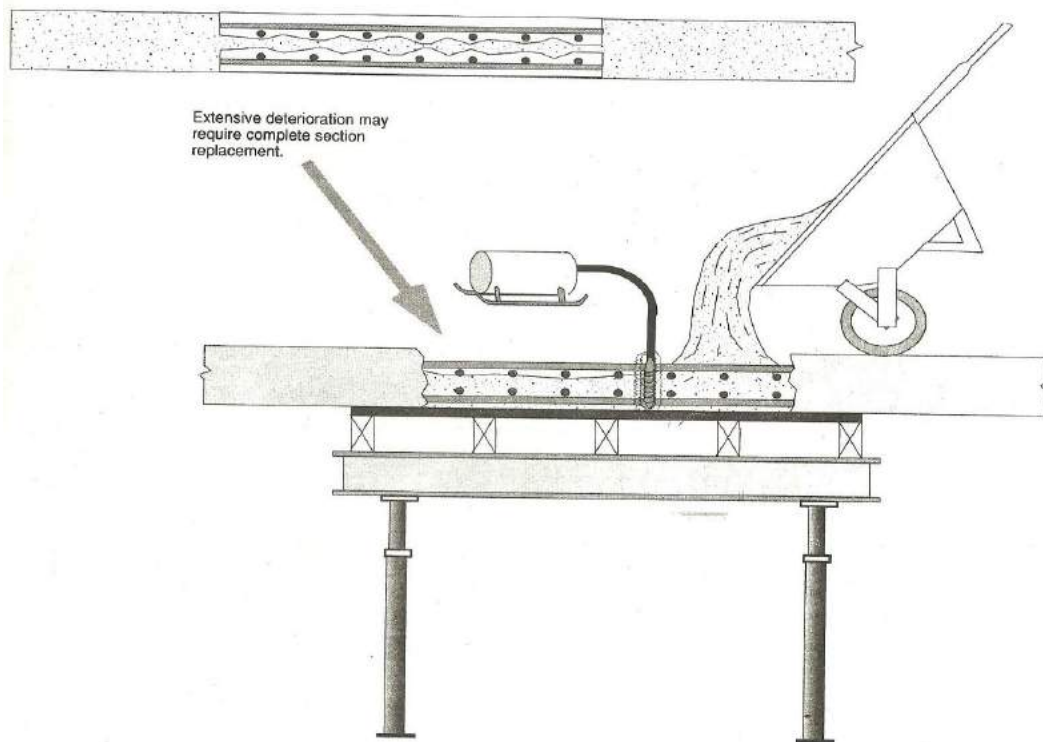

Overlays: Overlays are used to repair concrete structures as a remedy for a variety of concrete problems. They may be used to improve drainage, rideability, or load carrying capacity; to increase skid resistance; or to protect underlying concrete from aggressive environments. Many overlays also address underlying surface deterioration problems. Overlays can be constructed of different materials from very thin (3mm) to very thick.

Bridge and parking decks, as well as concrete pavements, are common locations for the use of bonded overlays for restoring existing worn and deteriorated concrete.

Common materials used in the overlays are low water/cement ratio Portland cement concrete, latex- modified Portland cement concrete, and microsilica-modified Portland cement concrete.

Most bonded overlays used in parking and bridge decks and pavement repairs involve thickness ranges of 1.5" to 3" (38mm to 76mm). Many applications do not require additional reinforcement. Overlays require special attention to placement techniques to prevent various problems such as plastic shrinkage cracking, lack of consolidation, segregation, or poor bonding.

Overlays for bridges and parking structures generally include surface repairs to deteriorated areas of the deck. Hand or power screeds are used to level and consolidate the overlay materials. Normal Portland cement, latex modified or microsilica modified concrete are used for overlay systems.

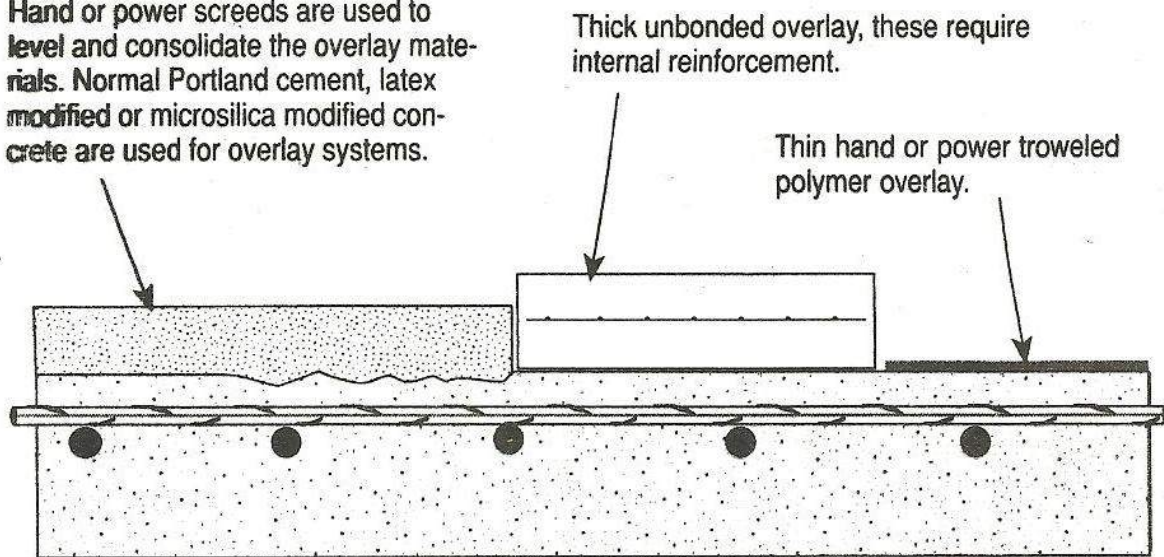

Thick unbonded overlay, these require internal reinforcement.

Thin hand or power troweled polymer overlay.

❖ **Protective Surface Treatments:** Durability of concrete can be substantially improved by preventive maintenance in the form of weather-proofing surface treatments. These treatments are used to seal the concrete surface and to inhibit the intrusion of moisture and/or chemicals. Materials used for this purpose are oils such as, linseed oils, petroleum oils, etc. Silicons used to seal concrete and masonry structures against moisture, Epoxies.

➤ **Hand-applied Treatments:** Hand-applied techniques are used to place non-sag repair materials on vertical and overhead locations. Most hand-applied materials are special blends of cement, finely graded aggregates, non-sag fillers, shrinkage compensating systems, and water. The mixed material is applied to the prepared surface with either a trowel or by hand. The applied pressure drives the repair material into the pore structure of the exposed concrete. The repair material is designed to "hang" in place until subsequent layers are added. Each layer is roughened to promote bond with the next layer.

The best use of this technique is for topical cosmetic repairs not involving reinforcing steel. When reinforcing steel is encountered, it is very difficult to consolidate and provide for complete encapsulation of the reinforcing steel. Problems associated with this technique involve poor bond between layers and voids around embedded reinforcing steel.

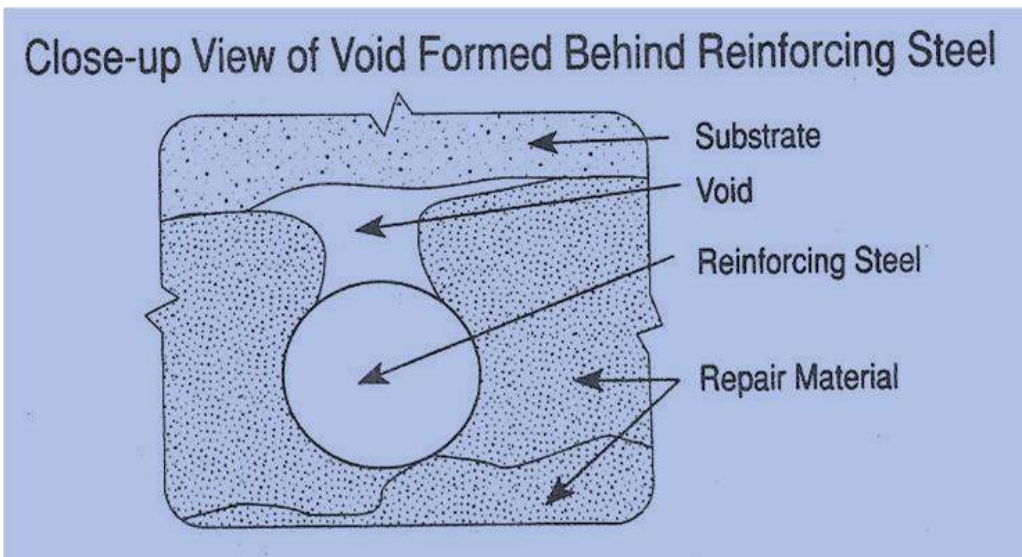
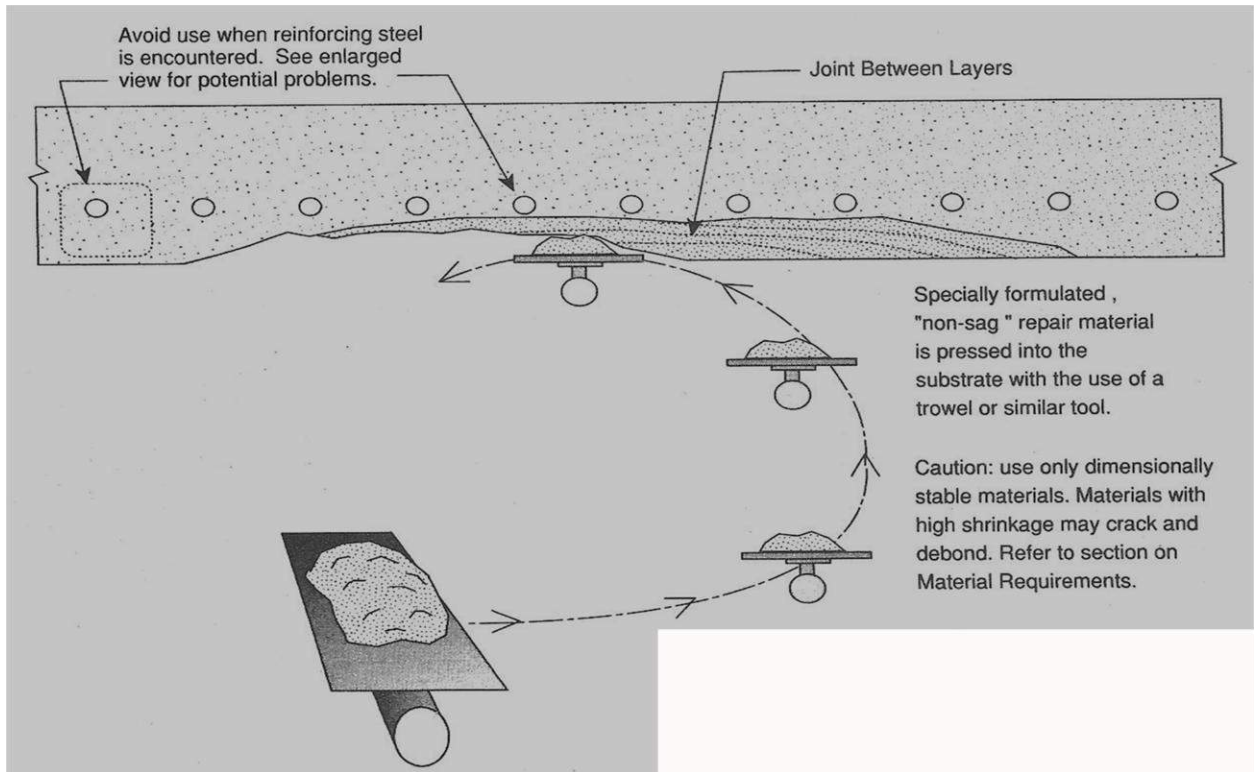

BROAD CLASSIFICATION

Repair & Retrofitting

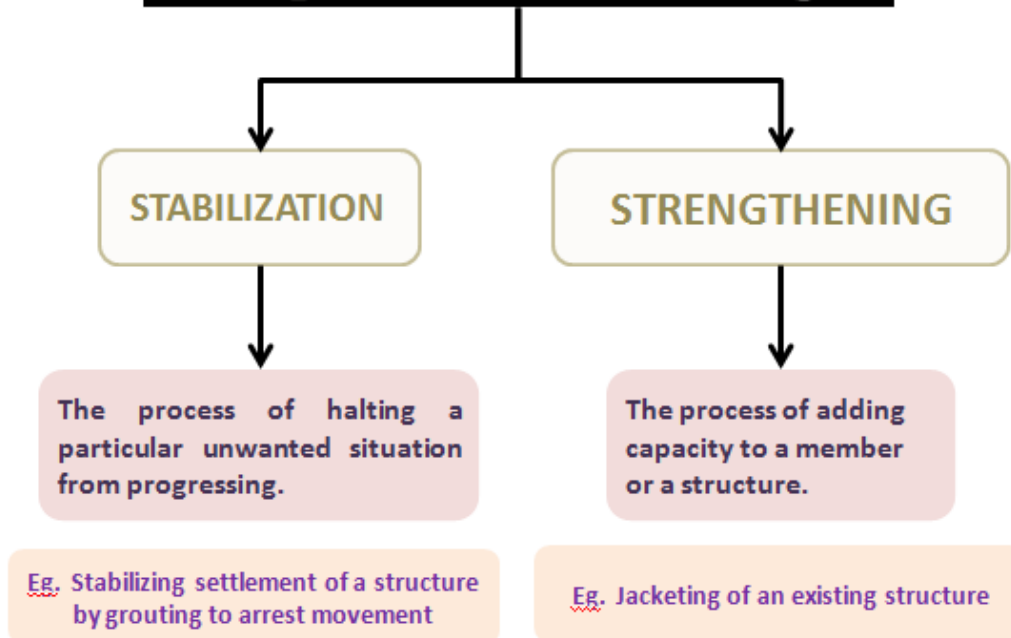

Retrofitting Techniques

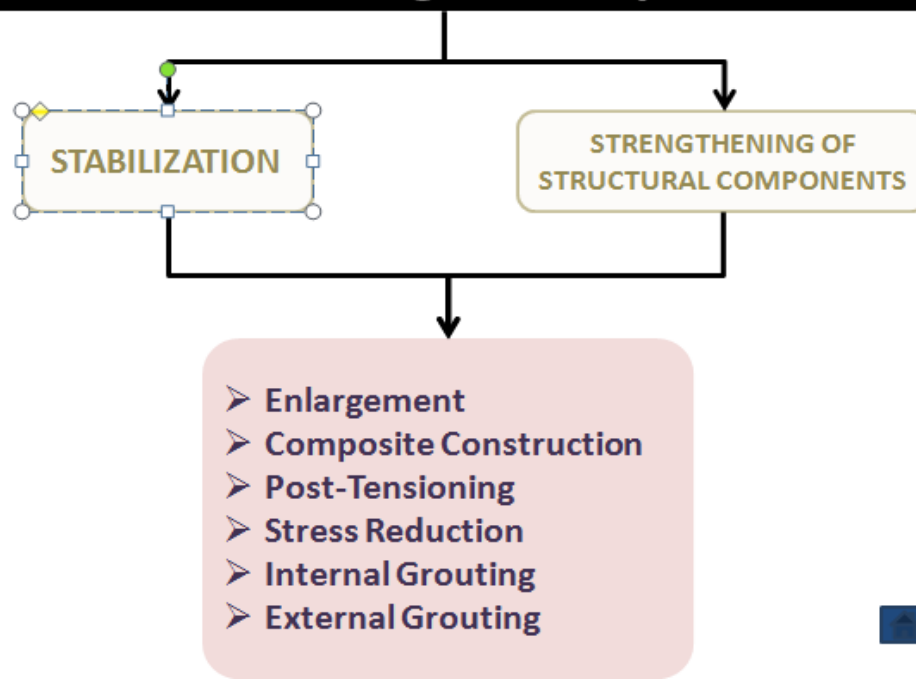

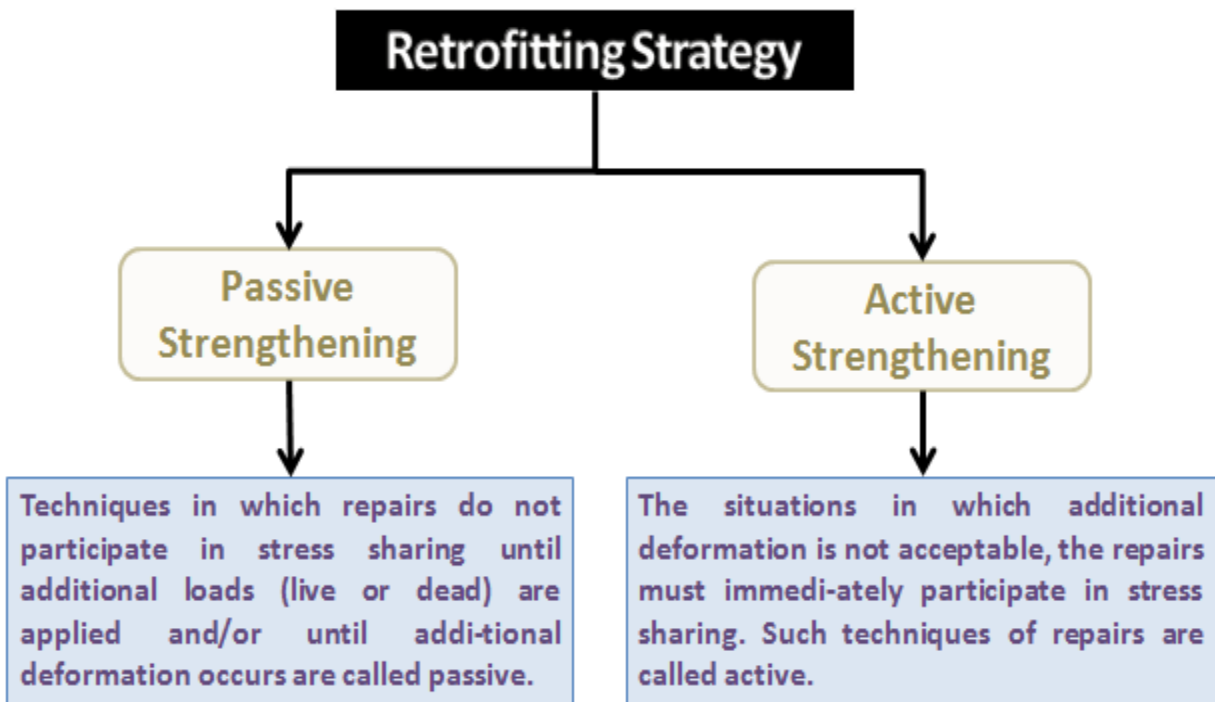
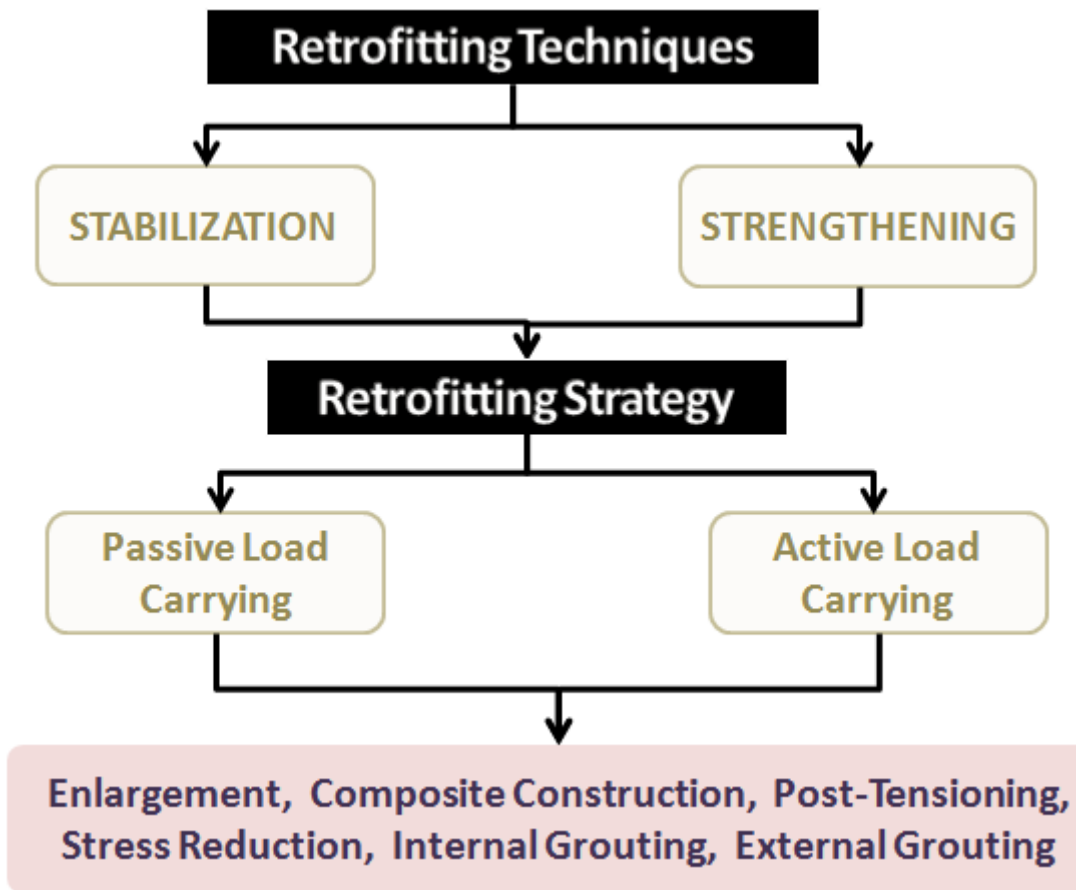

Enlargement: Enlargement is the placement of additional concrete and reinforcing steel on an existing structural member. Beams, slabs, columns, and walls, if necessary, can be enlarged to add stiffness or load-carrying capacity.

Example: **Jacketing**

Composite Construction: Composite construction is a method wherein materials other than concrete are placed in concert with an existing concrete member to add stiffness or load carrying capacity. Steel is the most common material used in this technique. Steel plates and structural shapes can be fabricated to meet almost any configuration requirement. Load transfer in the composite member is accomplished by the use of adhesives, grouts, and mechanical anchorage systems.

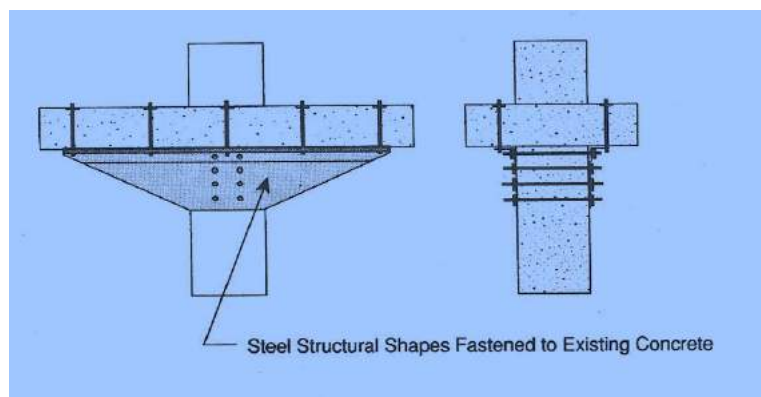

Post-Tensioning: Post-tensioning is a technique used to prestress reinforced concrete. The tensioning provides the member with an immediate and active load-carrying capability. Placement of the tension components can be achieved either internally within the member or externally to the member.

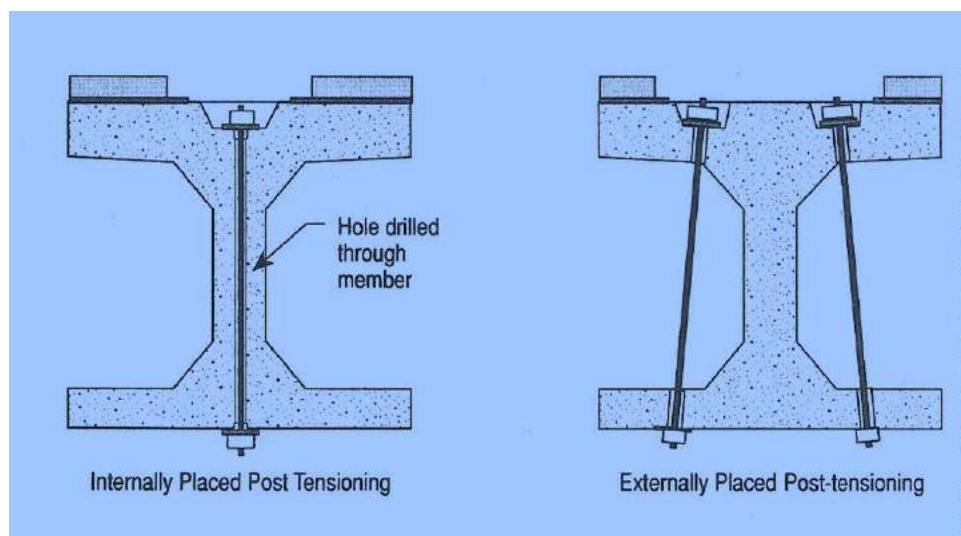

Tension components are generally steel plates, rods, tendons or strands. Tension is imparted to the components by jacking or, less commonly, by preheating. Post-tensioning enhances a member's ability to relieve overstressed conditions in tension, shear, bending, and torsion. The post-tensioning technique can also be used to eliminate unwanted displacements in members and to turn discontinuous members into continuous members.

Stress Reduction: Stress reduction is a technique that reduces stress in a member or structure. Some of the more common methods of stress reduction include cutting new expansion joints, jacking displaced structures, and installing isolation bearings. Other more radical techniques involve the removal of portions of structures.

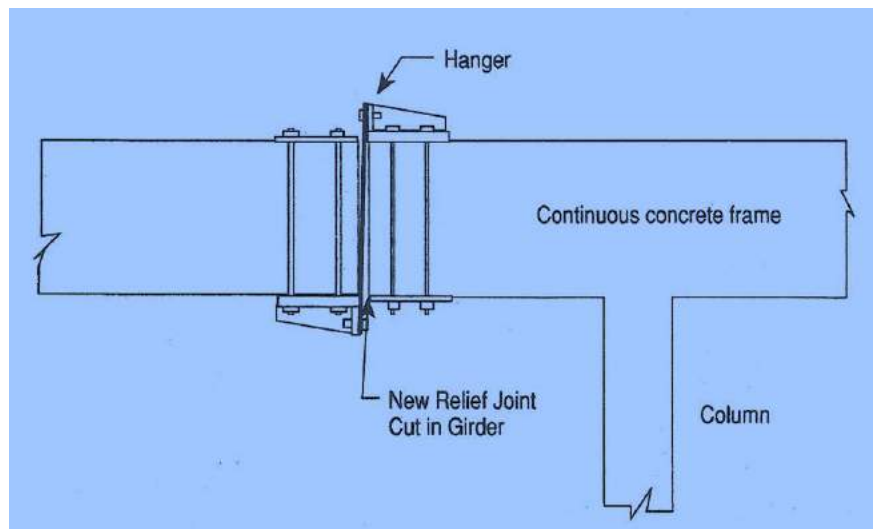

Internal Grouting: Internal grouting is the placement of a flowable material into an unwanted discontinuity, such as a crack within the concrete member. The flowable material, upon reaching the discontinuity, will solidify and assume necessary structural properties. Internal grouting is used to repair fractured, honeycombed, or voided concrete placements. The most common materials used for internal grouting are polymers and hydraulic cement-based materials.

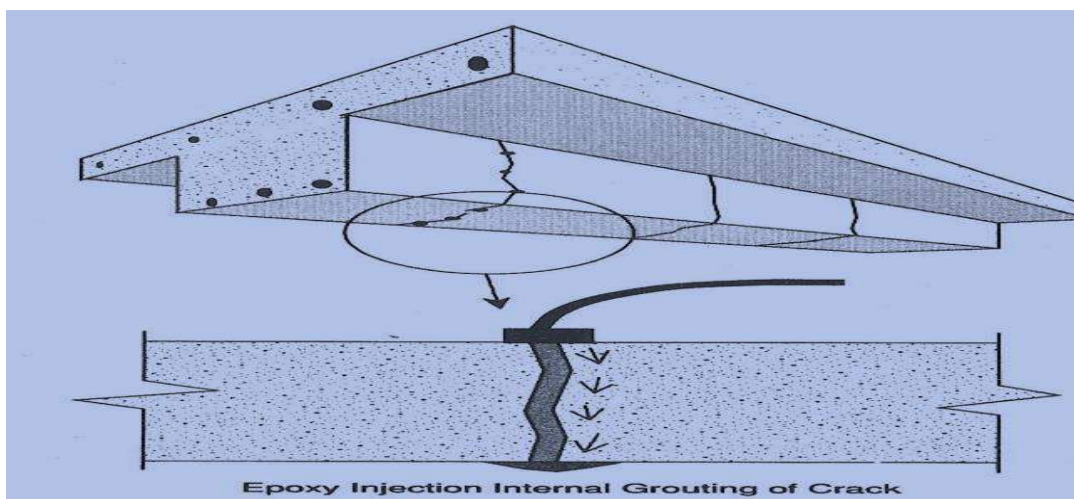

External Grouting: External grouting is the placement of a pumpable material outside the structure, generally within the surrounding foundation soils or at the interface between the structure and the soil. The grouting materials can be used either to provide necessary load transfer between the structure and soil, or to displace unwanted settlement. Most materials used for external grouting include cement-based mixtures. Pavement subsealing (slab stabilization) is a specialized external grouting technique used to fill small voids beneath the slab and/or stabilized base that have been caused by pumping action.

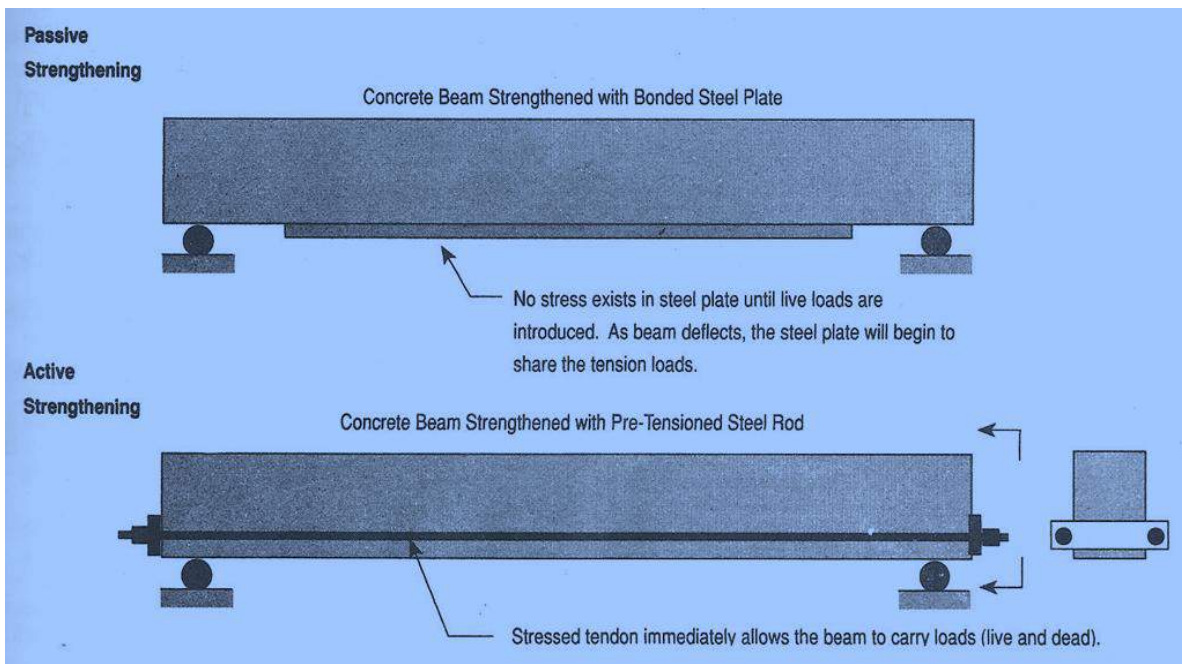
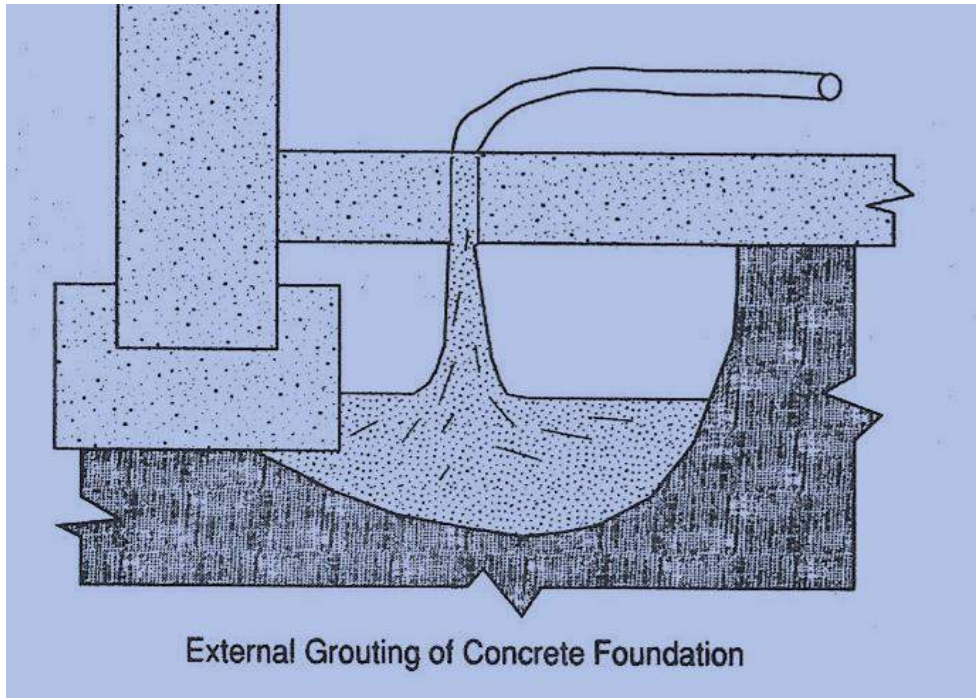

Beam Shear Strengthening

Beam shear capacity can be increased by using various strengthening techniques, including:

- external post-tensioning
- internal post-tensioning
- internal mild steel reinforcement
- bonded steel members
- enlarging member's cross-section

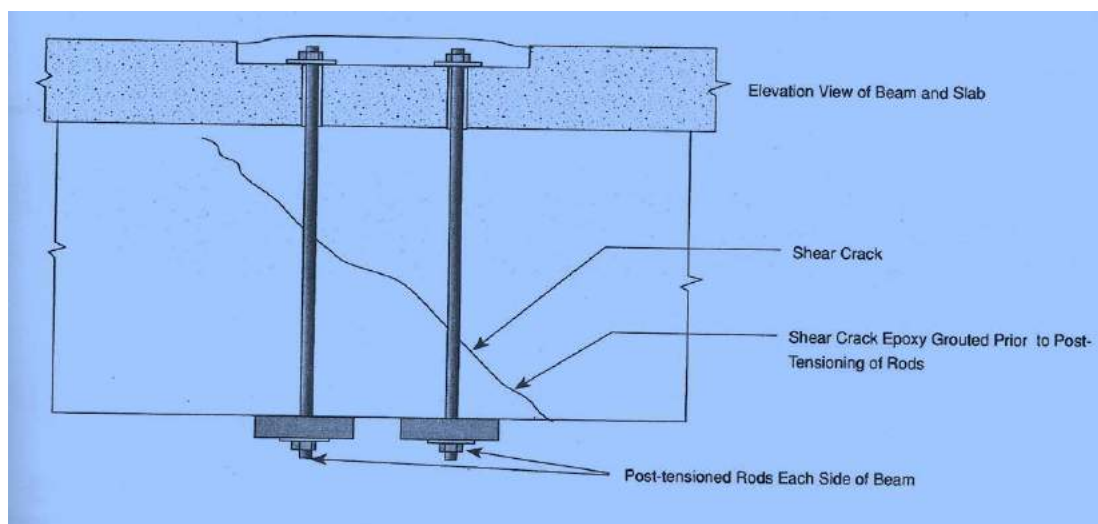
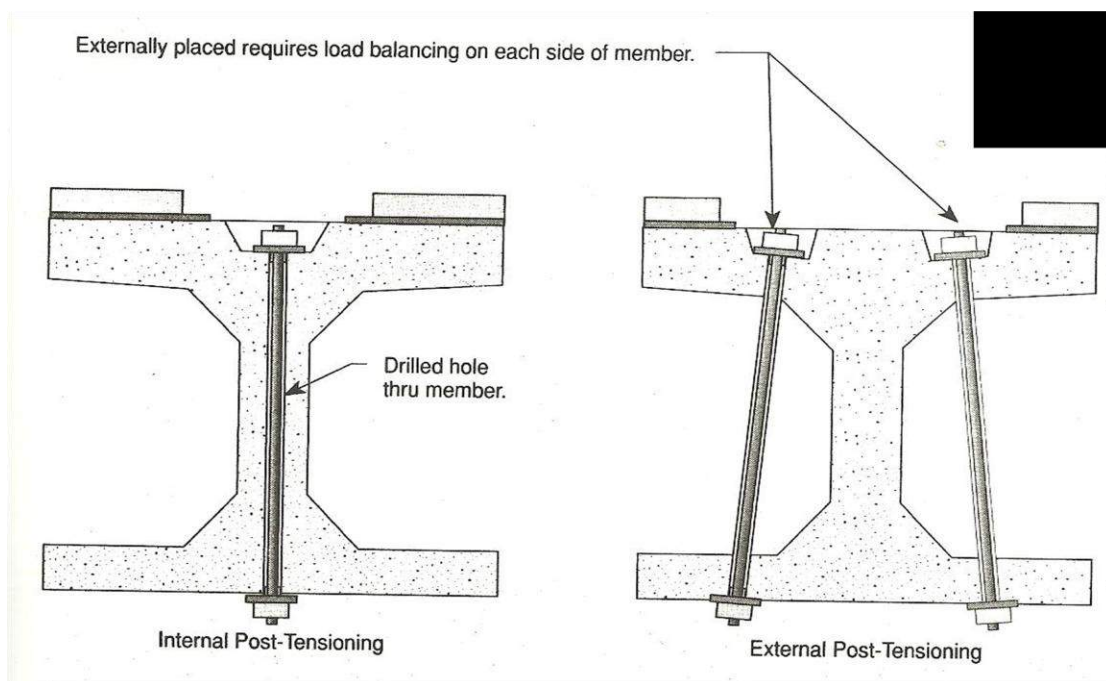

Internally Placed Passive Shear Strengthening

Strengthening of existing members to increase their shear capacity can be performed by adding shear reinforcement. For example, the use of mild reinforcement dowels inserted perpendicular to the direction of shear cracking, into drilled holes. The dowels are then grouted into place with epoxy.

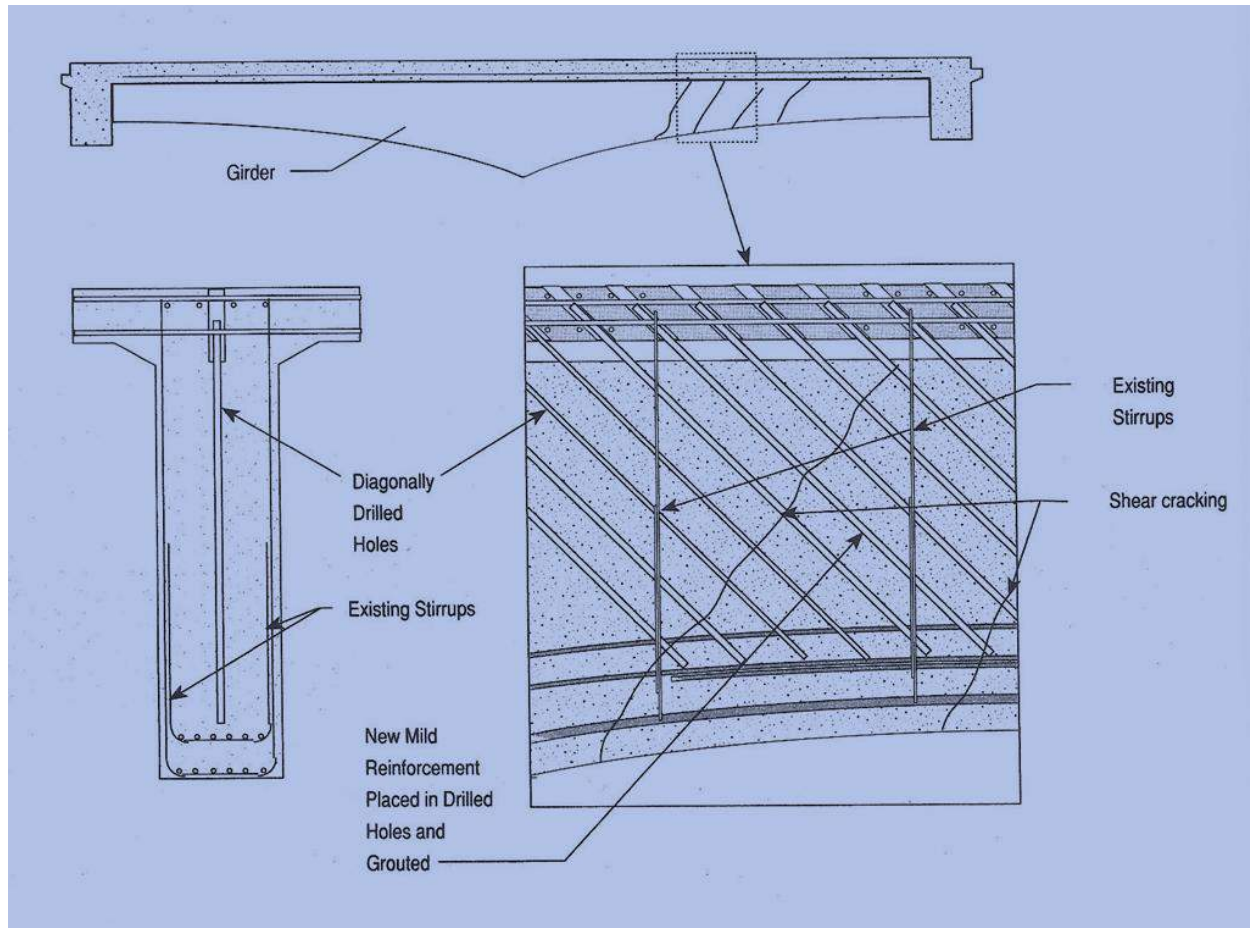

Beam Shear Capacity Strengthening at Moving Hinge

If a significant thermal gradient exists, in combination with insufficient tensile capacity in the bottom of the member, a hinge may form. Hinges may occur randomly in newly formed cracks, or may form in construction joints near the columns. Hinges open and close with daily temperature changes.

Cracks can be a cause for structural concern, since they sometimes identify insufficient shear capacity. When strengthening the member by repairing cracks, consideration must be given to the need for providing movement of the hinge. Generally any repair of a moving crack by bonding it with epoxy will fail.

Diurnal solar heating causes camber in member.

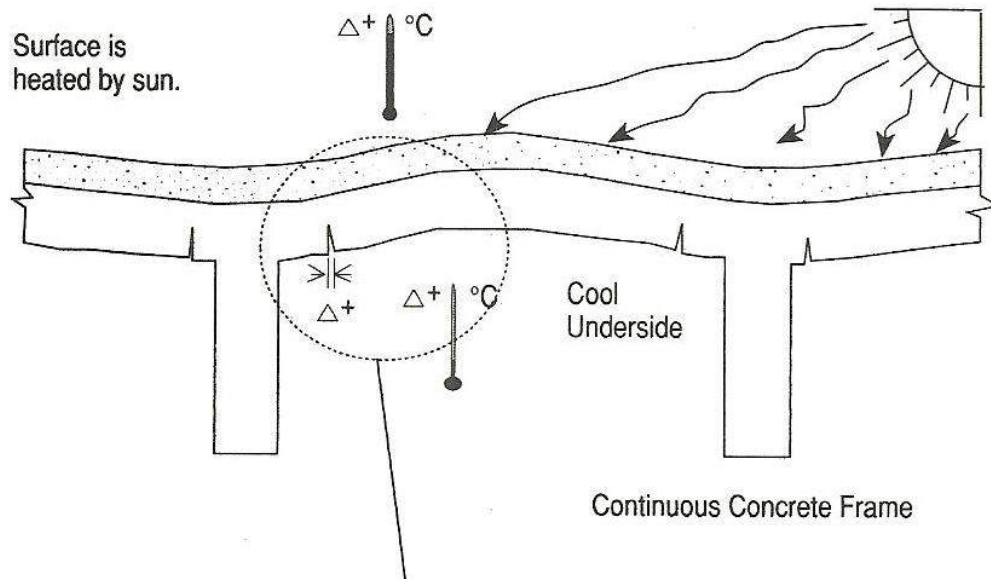

An effective method: the installation demonstrates how to strengthen a cracked beam with a post-tensioned shear clamp and a teflon slide bearing allowing for hinge movement.

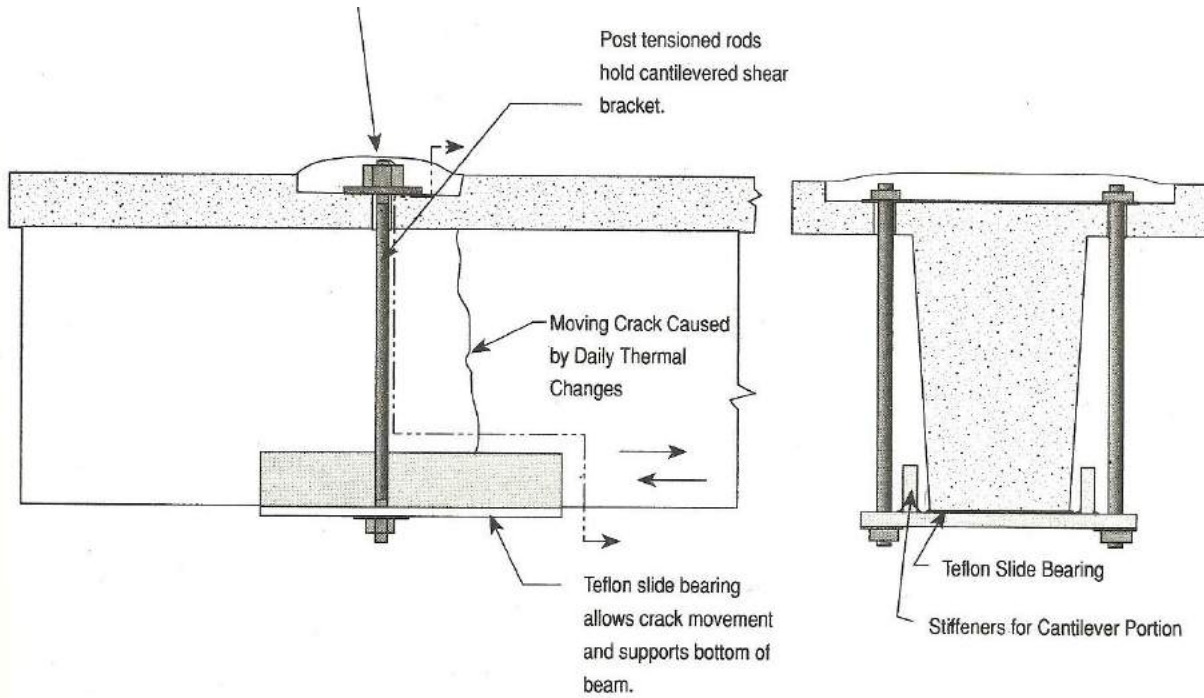

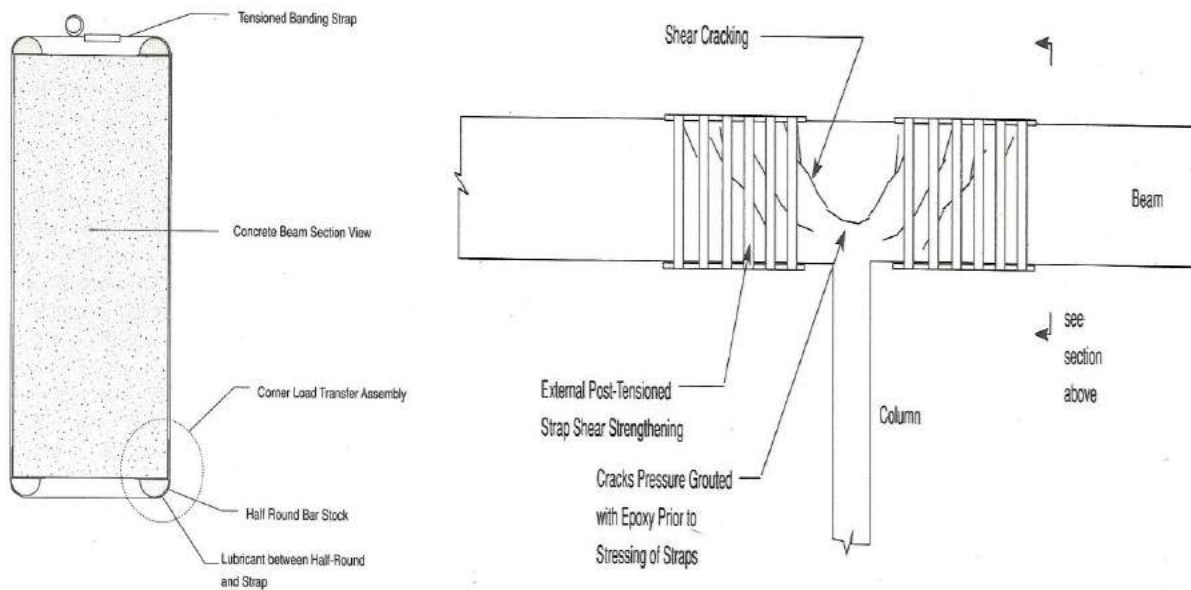

Shear Transfer Strengthening between members

- Dowel Shear Device
- Drilled Hole Shear Transfer Device
- Grouted Subgrade
- Cantilever Shear Arm

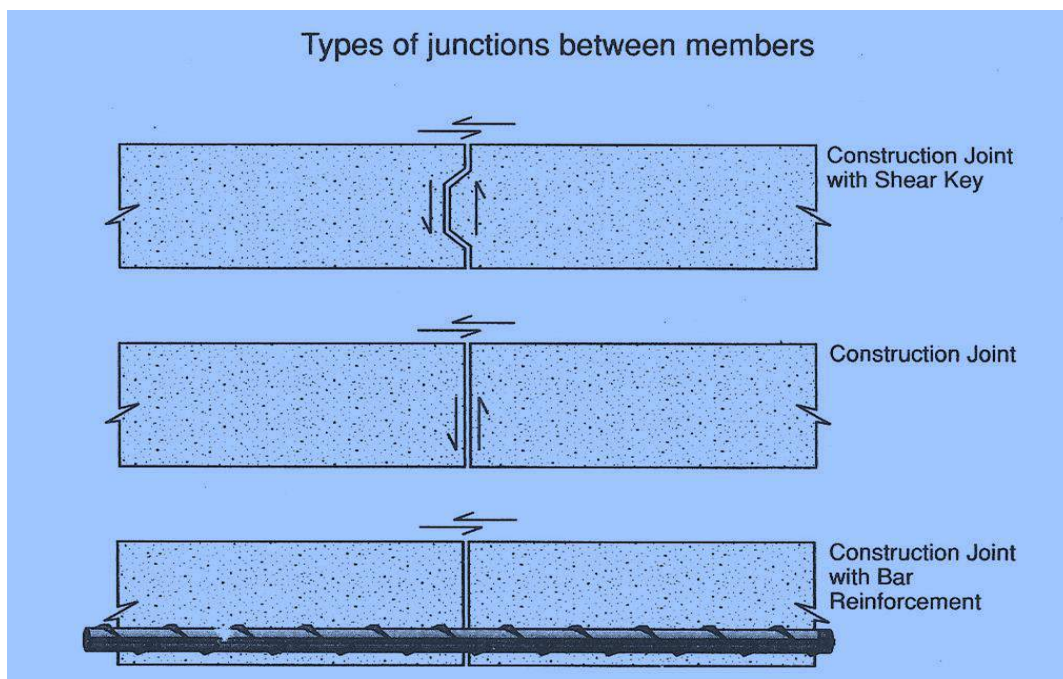

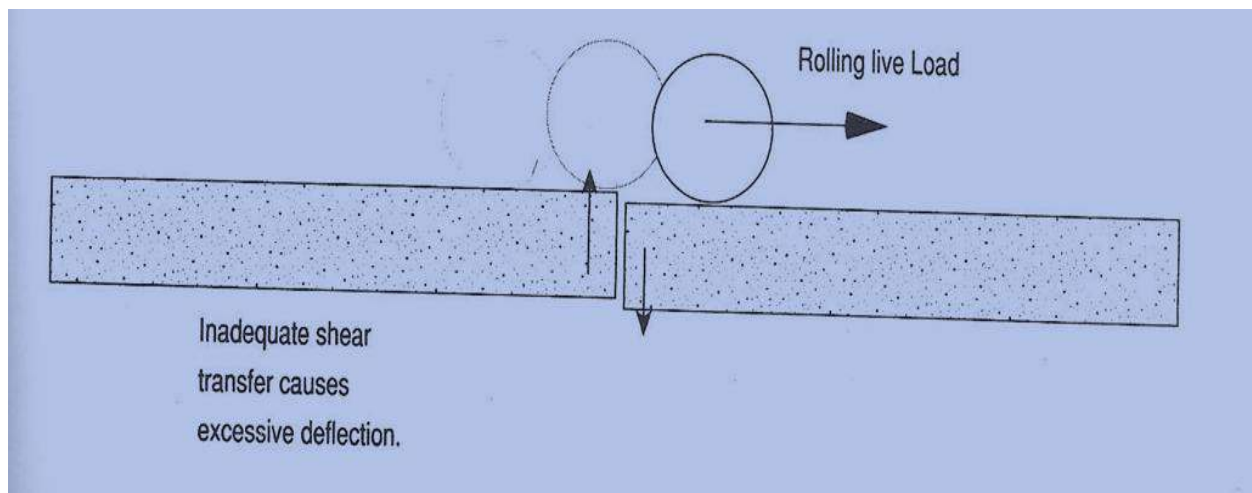
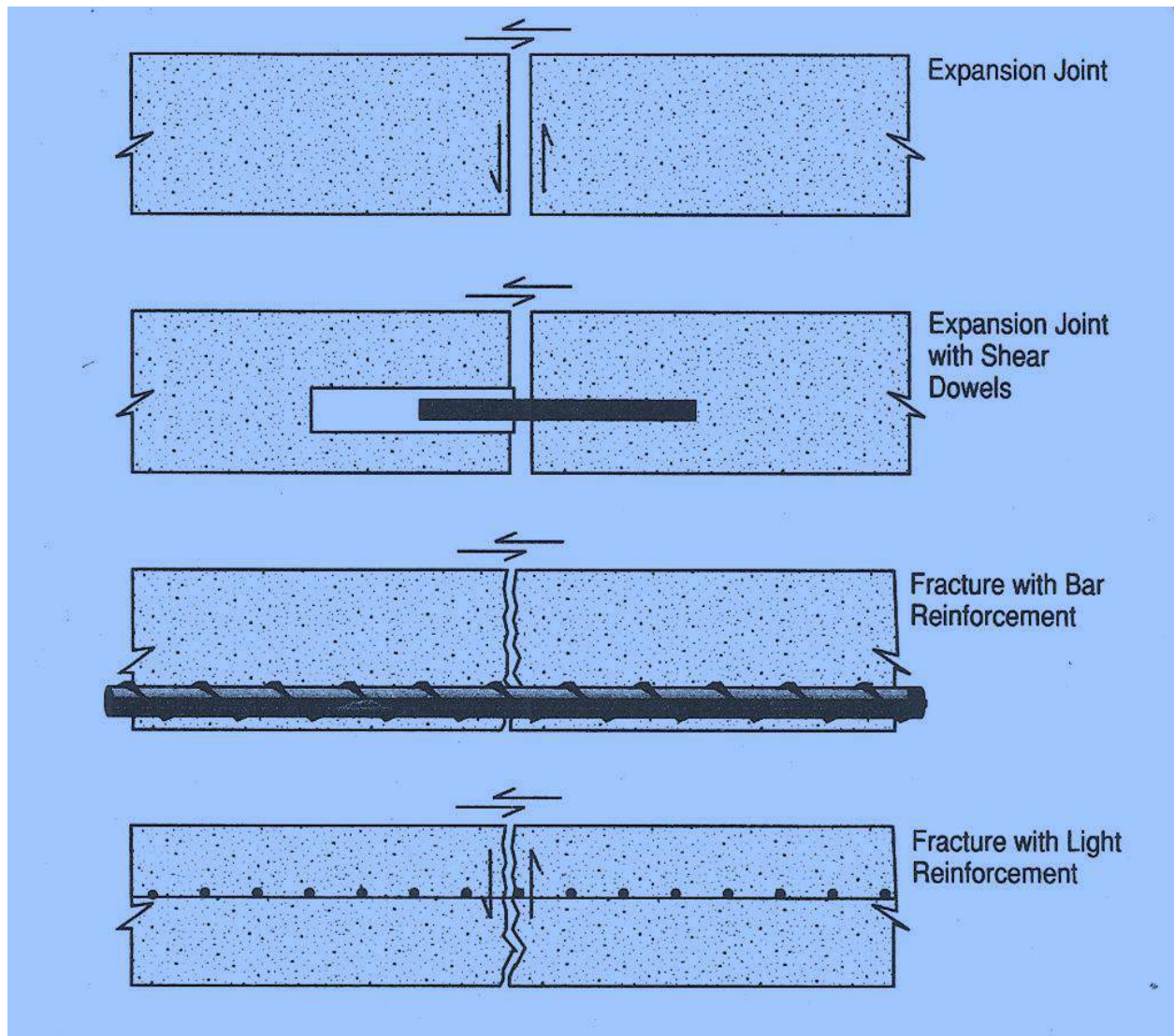

Fig. Dowel Shear Device

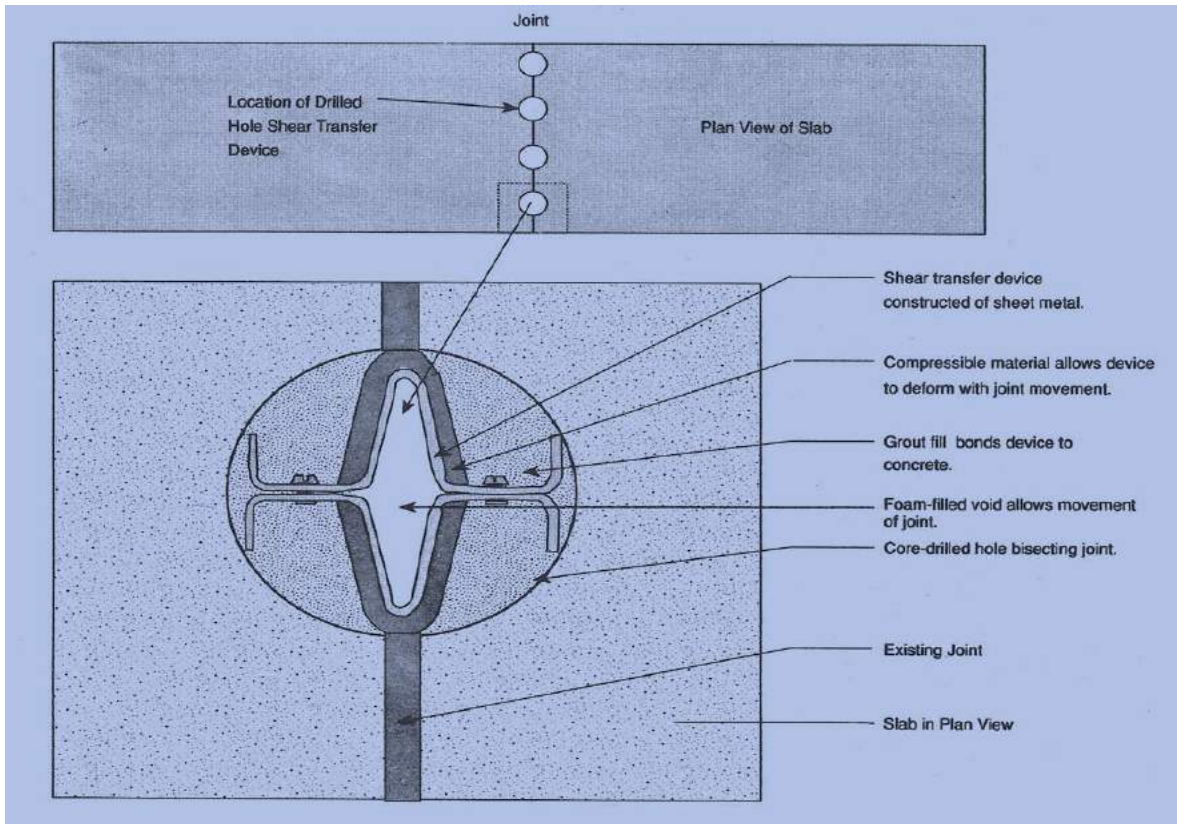

Fig. Drilled Hole Shear Transfer Device

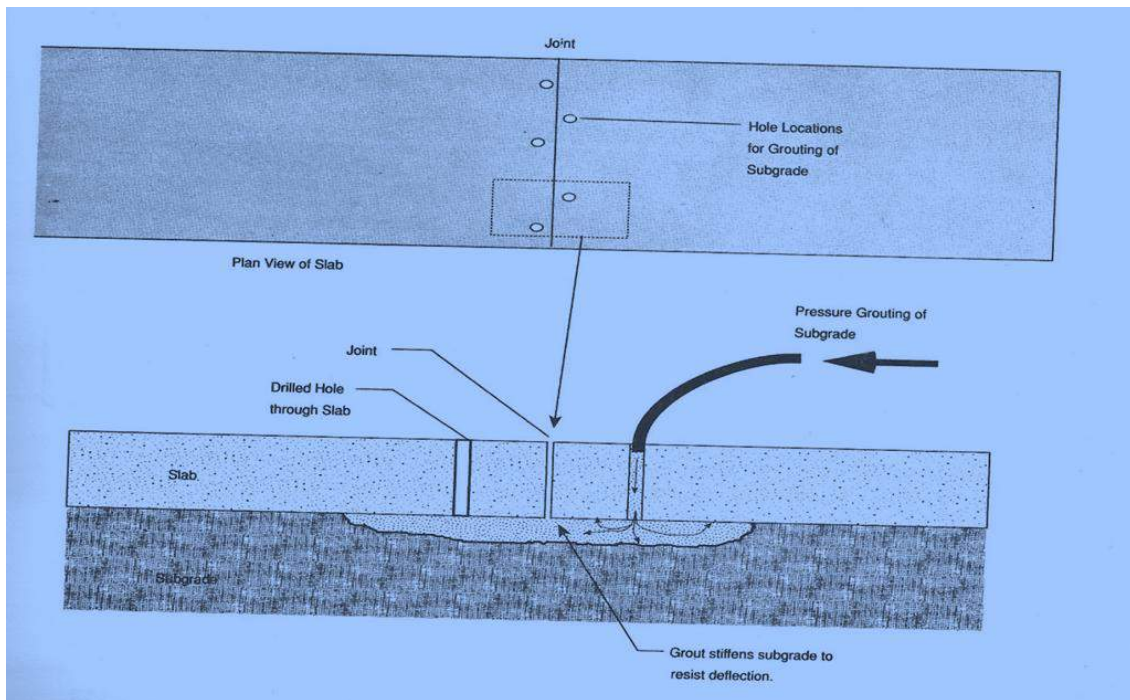
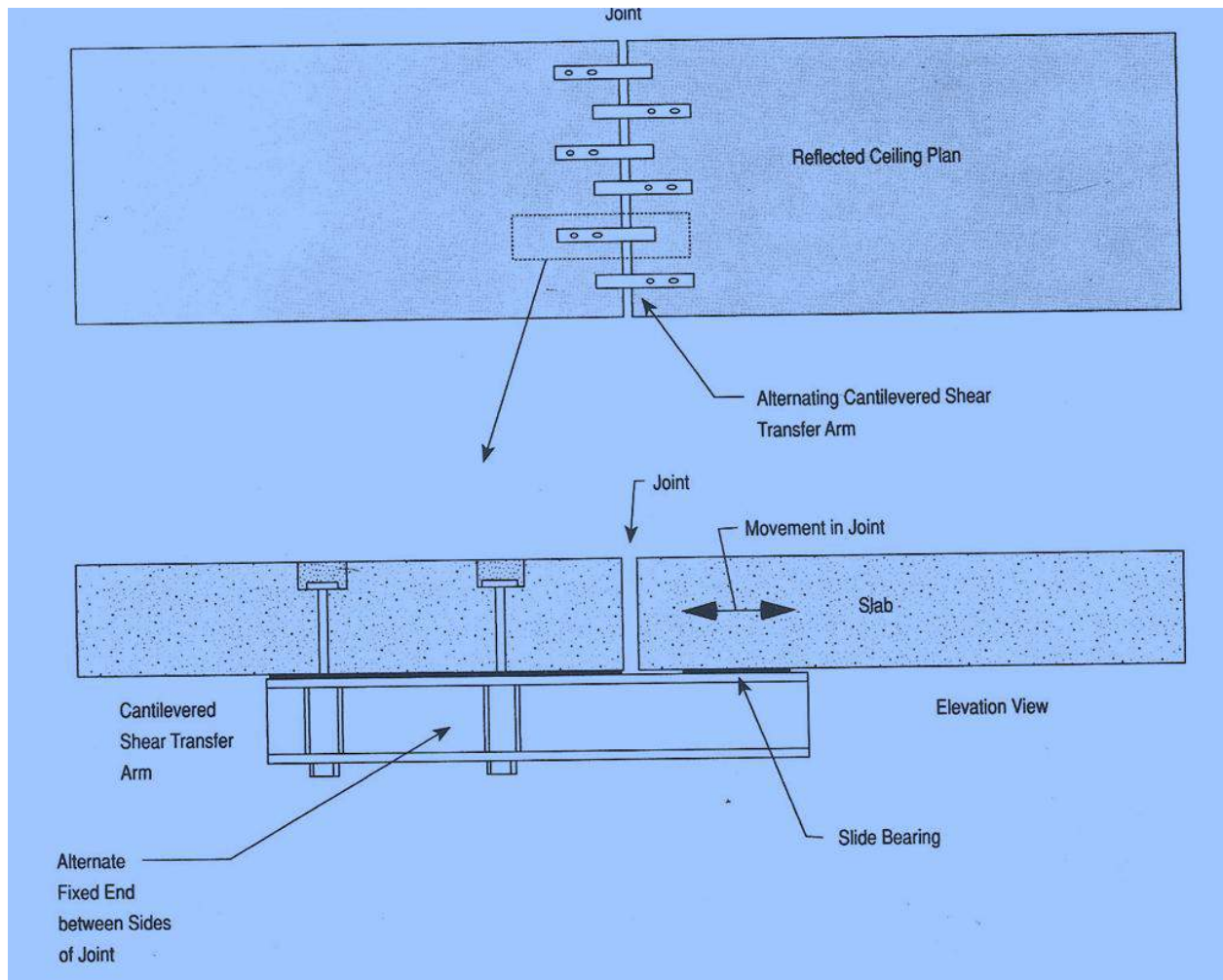

Fig. Grouted Subgrade



Cantilevered Shear Arm

STRESS REDUCTION TECHNIQUES

Installing New Expansion Joint: Overstressing in members and structures can be repaired utilizing stress reduction techniques. Stress can be reduced by either reducing the load applied to the structure, or by modifying the behaviour of the structure.

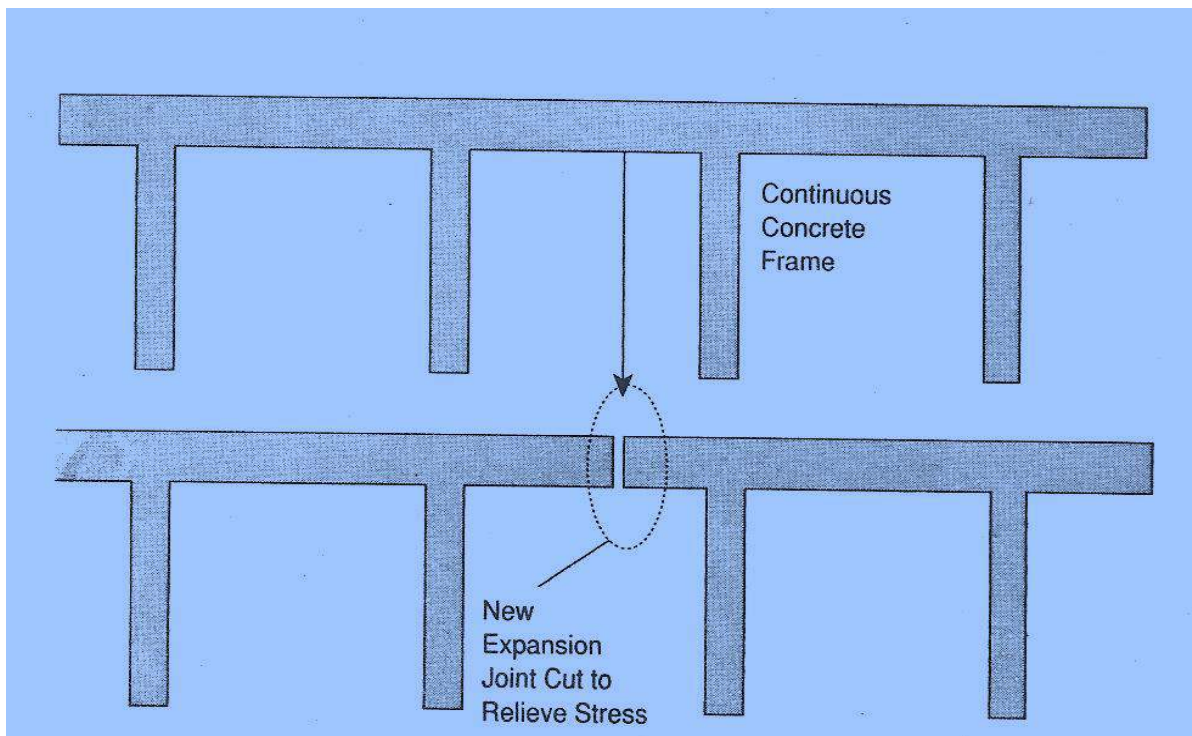
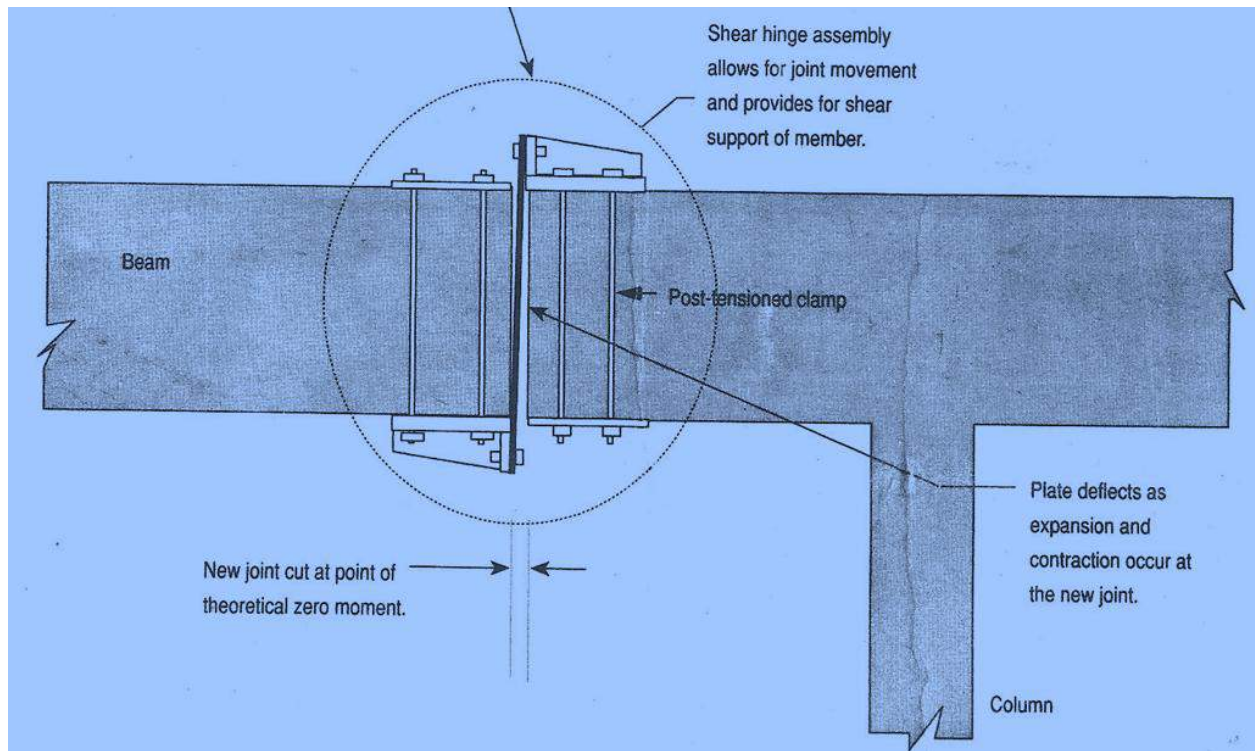

Lateral Ground Movement Isolation (Seismic Isolation)

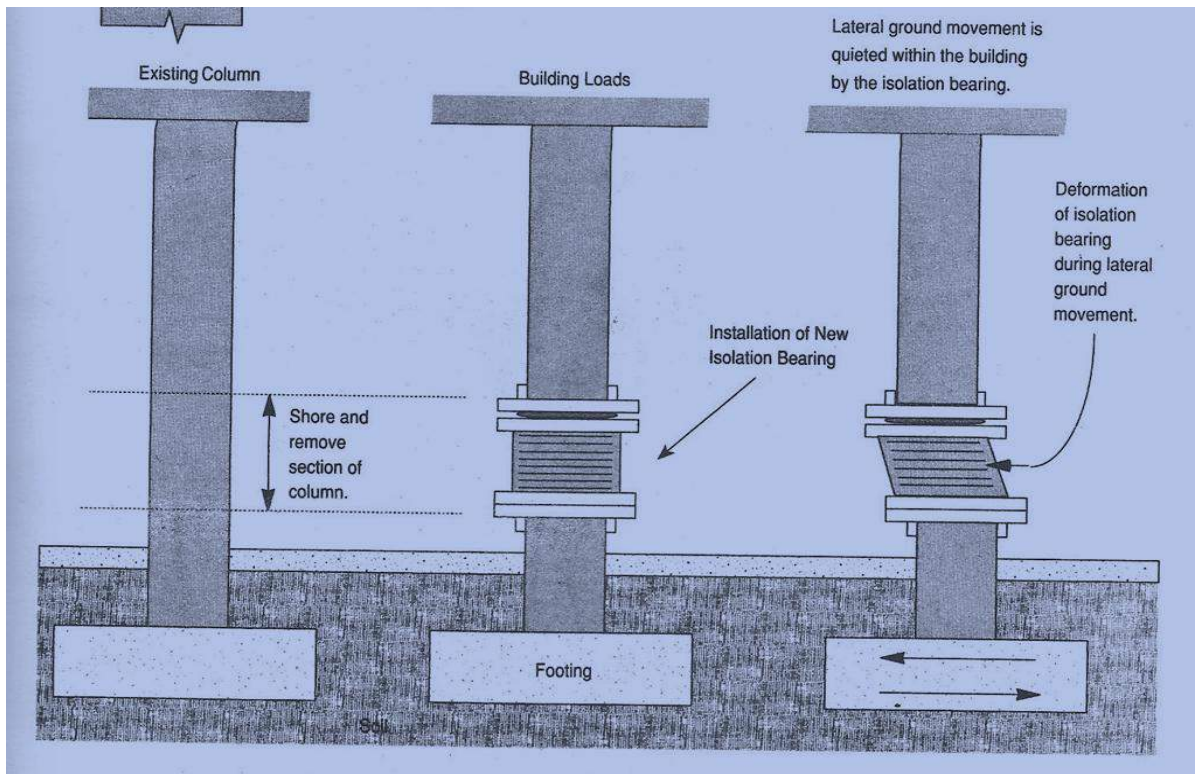
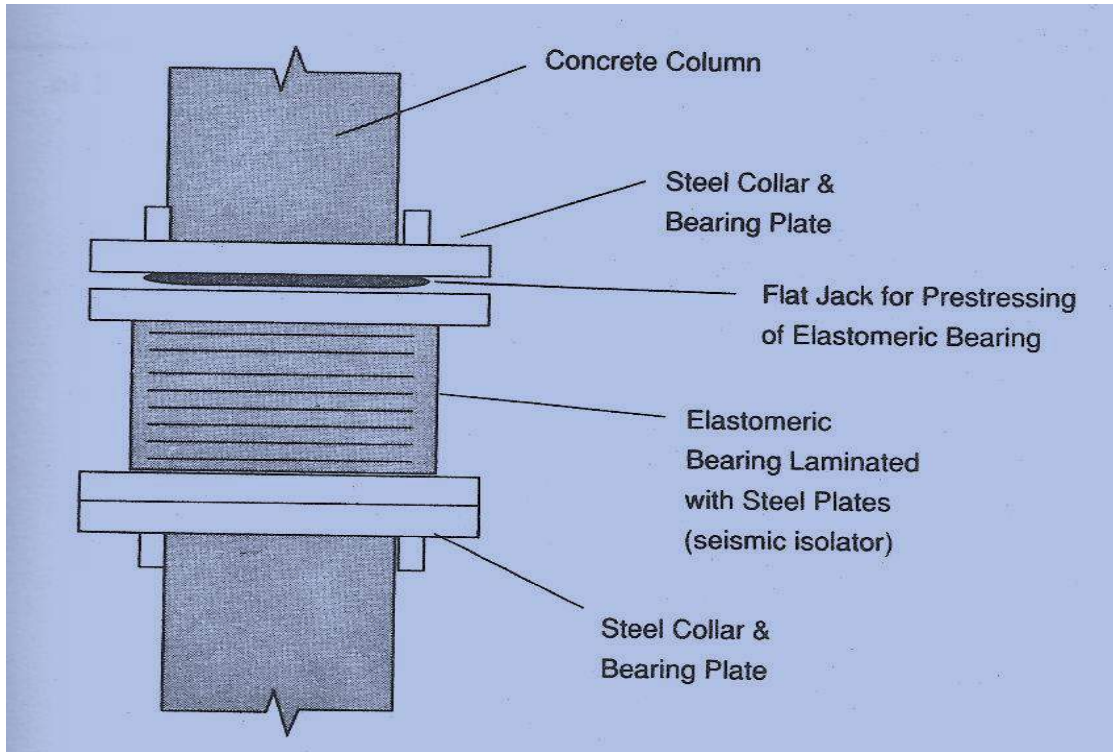

COLUMN STRENGTHENING

- Compressive Strengthening by Enlargement (Jacketing)
- Shear Capacity Strengthening using Shear Collars
- Beam-column Moment Capacity Strengthening
- Confinement Strengthening

Jacketing: Section Enlargement

Enlarging the cross section of an existing column will strengthen the column by increasing its load carrying capacity. This is called Jacketing.

TOPIC 5: STRUCTURAL HEALTH MONITORING, DAMAGE DIAGNOSIS & ASSESSMENT

Structural Health Monitoring

Structural Health Monitoring is a process of real-time, on-line and automated evaluation of a structure's integrity and performance, prediction of the remaining serviceable life of structure and timely warning to the end-user of its deterioration.

Typically, a critical structure in service is monitored for

- (a) the strength of the constituent materials,
- (b) the stresses due to loads to be with permissible limits,
- (c) deflections and strains for appropriate serviceability conditions
- (d) the integrity of the structural assembly at its joints,
- (e) occurrences of damages etc.

This is done so as to take a suitable rehabilitation and retrofitting work to prevent a catastrophic failure.

Need for Continuous Monitoring of Structures

Analysis and Design Phases

- Imperfections in Analysis and Design
- Assumptions of ideal construction conditions

Construction Phases

- Compromises in implementing the design
- Poor quality of materials and workmanship

Degradation

- Deterioration of material properties with time
- Damages due to excessive loading and unforeseen impacts
- Environmental effects on material properties

Natural Calamities

- Earth Quakes
- Storms and Cyclones
- Floods and Tsunamis effect on structures built over water bodies

- Chemical Attacks

- Periodic Visual Inspections and Localized NDTs will not help in detecting suddenly manifesting changes in the structure
- These techniques require expertise in analysis and assessment of structural integrity
- Being localized techniques they cannot give a global evaluation of the structure
- The deteriorating portions of the structure may be inaccessible for NDE.
- Most of the times for NDE, the portion of the structure being inspected is rendered unusable throughout the length of the tests

Real-time on-line automated health monitoring:

Real-time implies that the monitoring is continuous even during the service period of the structure and the level of responsiveness of such a system is quick enough to enable appropriate remedial action or evacuation.

On-line implies that the alerting system must use user friendly on-screen imaging and audible alarms.

Automated implies that the diagnosis and alerting system does not need human interference for its operation.

Motivation for such a Structural Health Monitoring System:

❖ **Structural View**

- predicts optimal use of the structure
- minimizes downtime of the structure
- avoids catastrophic failures

❖ **Constructor View**

- gives the constructor a scope for improvement in his products
- gives him a chance for repair before an embarrassing collapse of the structure

❖ **Maintenance Services View**

- drastically changes the work organization of maintenance services
- replaces scheduled and periodic maintenance inspection with performance-based (condition-based) maintenance
- reduces the present maintenance labor, in particular by avoiding dismounting parts where there is no hidden defect;
- by drastically minimizing the human involvement, and consequently reducing labor, downtime and human errors, and thus improving safety and reliability.

❖ **Improving Safety (Most important reason)**

- To overcome failures due to unsatisfactory maintenance
- To detect the deterioration and aging of the structure before it becomes critical

❖ **Reducing Accidents and Losses**

❖ **Economic savings primarily for end users**

Levels of System Identification

SHM is classified into two categories, namely the Diagnosis and Prognosis.

Diagnosis: Through diagnosis, one can determine the presence of a flaws, their location, and their extent along with the possibility of looking at the delaying the propagation of flaws in the structure.

Prognosis: The prognosis part uses the information of the diagnosis part and determines the remaining life of the structure.

The SHM can be broadly divided into following levels.

Level 1: Confirming the presence of damage

Level 2: Determination of location and orientation of the damage

Level 3: Evaluation of the severity of the damage

Level 4: Possibility of controlling or delaying the growth of damage

Level 5: Determining the remaining life in the structure (prognosis)

Components of Structural Health Monitoring System

- Sensing Technology
- Diagnostic Signal Generation
- Signal Processing
- Damage Identification Analysis
- System Integration

Sensing Technology: It consists of an array of distributed sensors, either wired or wireless to interrogate the structure at periodic intervals or continuously.

Diagnostic Signal Generation: This involves generation of suitable signals from the sensors, which must reflect the desired parameters in the health assessment of the structure, with the properties of controllability, repeatability, reliability and sensitivity to damages.

Signal Processing: This involves the necessary electronic components to efficiently transmit the diagnostic signal, while filtering out unwanted noise so that the signal analysis gives realistic picture of the state of the structure.

Damage Identification Analysis: This is considered as the brain of the SHM system as it relates the sensor measurements to the physical changes in the structures. It involves expertise in identification and characterization of damages using the knowledge of static and dynamic

structural mechanics, material properties and the physics of the specific sensing technology being used.

System Integration: This involves software development, with the support of suitable hardware components, to control the above mentioned components with a user friendly interface and must be capable of giving needed indications and warnings to the maintenance department or the user.

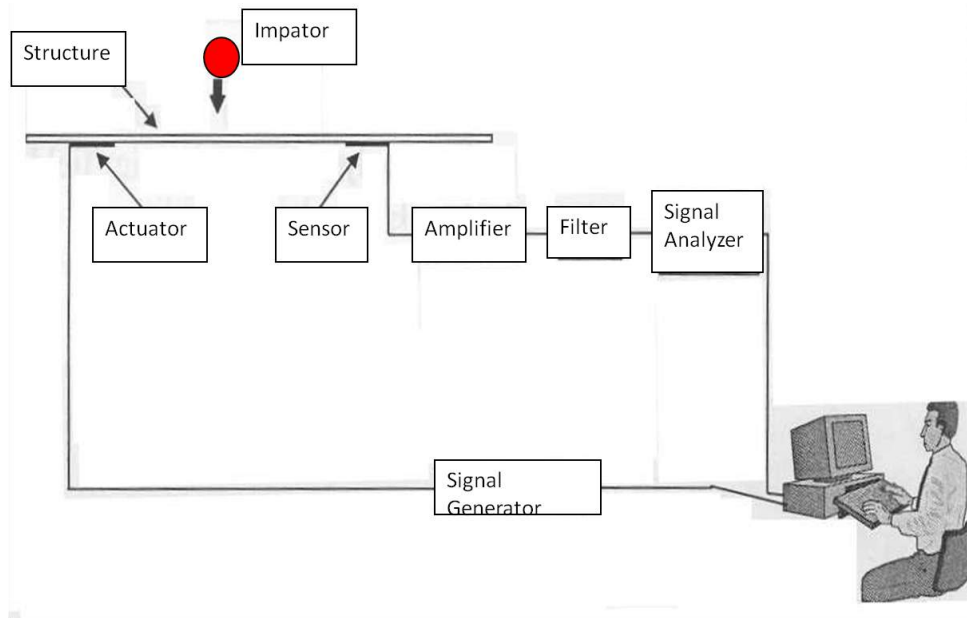

Figure illustrating the components and operation of typical SHM system

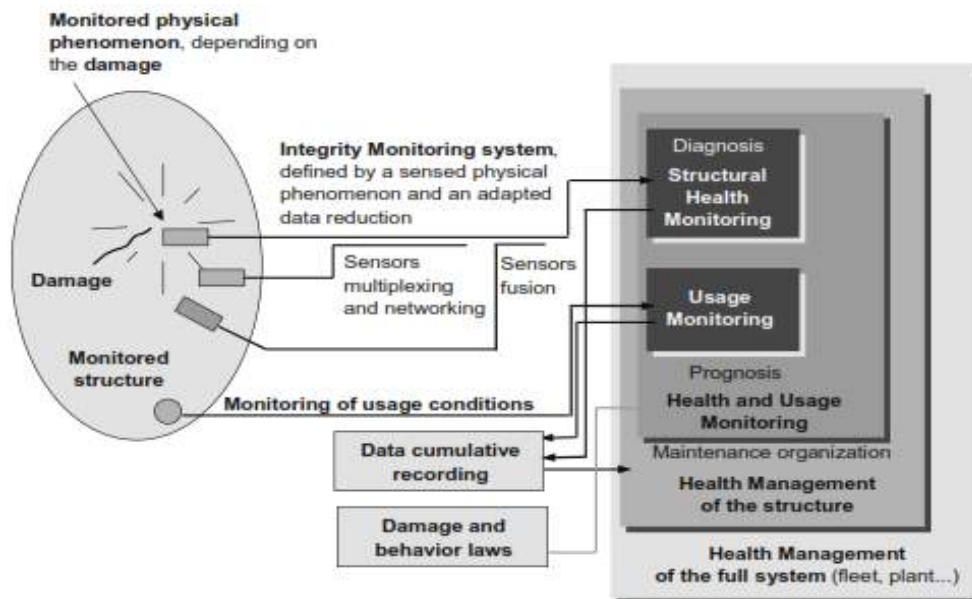

Figure 1.1. Principle and organization of a SHM system

Passive and Active SHM techniques

Actuator: An actuator typically is a mechanical device that takes energy — usually energy that is created by air, electricity or liquid — and converts it into some kind of motion. Actuator is used to generate force or induce displacement or vibrations.

Sensor: A **sensor** (also called **detector**) is a converter that measures a physical quantity and converts it into a signal which can be read by an observer or by an (today mostly electronic) instrument.

Passive SHM technique: If the monitoring process is based only on the diagnostic signal from the sensors, which is generated only upon occurrence of damage/deflections in the structure, such a technique is called “*passive monitoring.*”

Examples:

- (A) Monitoring with acoustic emission sensors
- (B) SHM using static displacement/strain gauges
- (C) SHM using velocity meters and accelerometers

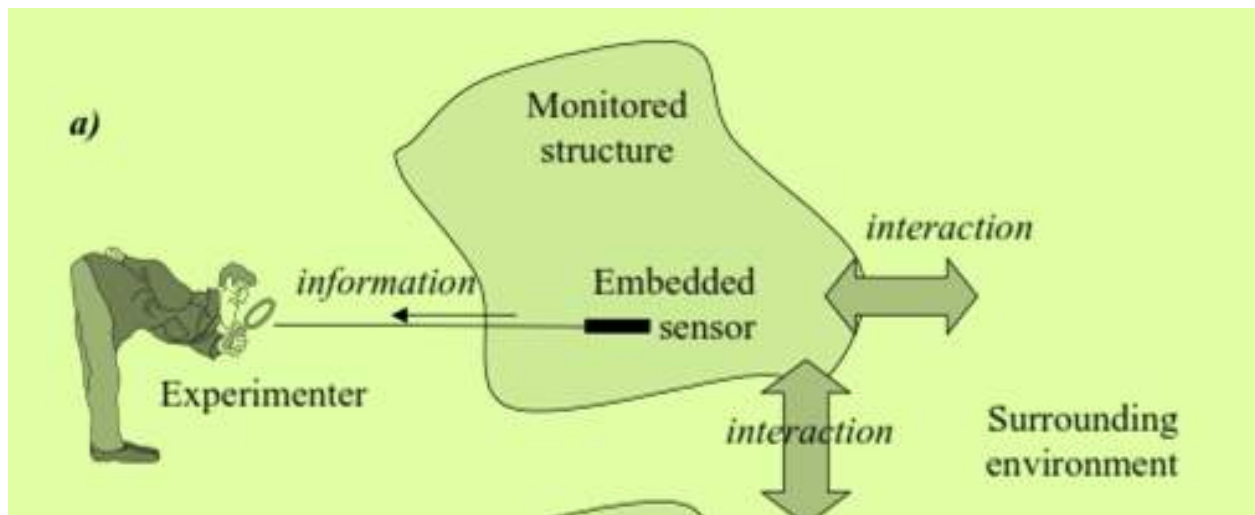

Fig. 1 Passive SHM

Active SHM technique: If the monitoring process is consisting of both actuators and sensors and some perturbations/vibrations are generated by the actuators and the structural response is captured by the sensors, which is then analysed for identifying damages, then such a technique is called “*active monitoring.*” In active monitoring technique the diagnostic signal is generated at will and not dependent on the situation where damage induced changes produce the diagnostic signal.

Examples:

(A) Ultrasonic Tests (Example: Impact-Echo method)

(B) Piezoelectric actuators and sensors based methods

(C) Vibration response based methods.

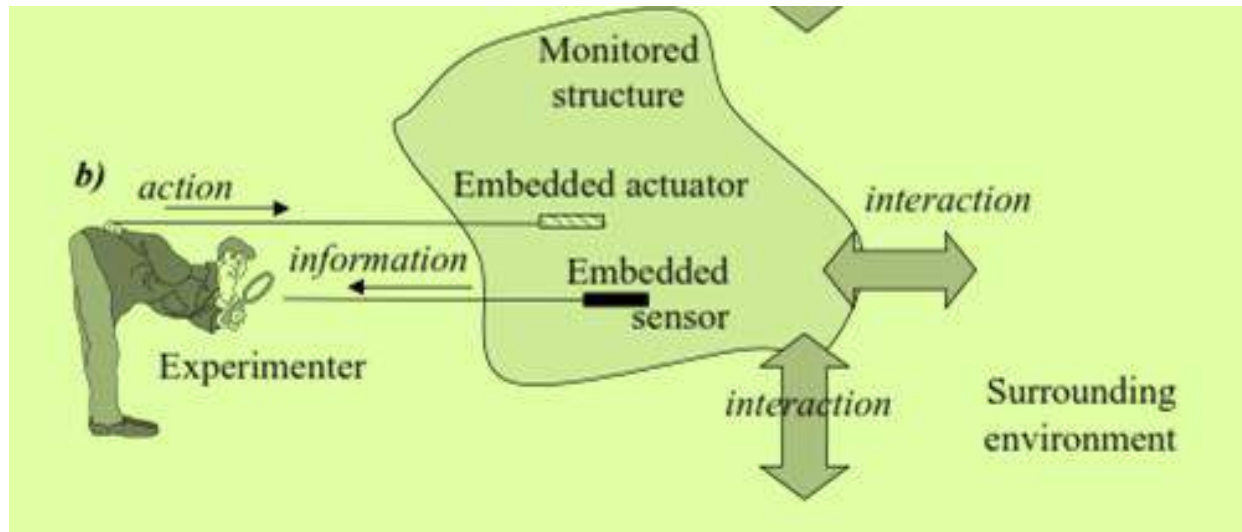

Fig. 2 Active SHM

Types of Sensors

- Displacement Sensors
- Vibration Sensors
- Optical Sensors
- Strain Sensors
- Acoustic Sensors
- Thermal Sensors

Sensors for SHM based on Structural Response

❖ Static Response

- Displacement Sensors Eg: Displacement gauges, LVDTs
- Strain Sensors Eg: Resistive Strain gauges

❖ Vibration/Dynamic Response

- Vibration Sensors Eg. Accelerometers
- Acoustic Sensors eg: Velocity receiver, ultrasonic thickness gauges

FIBRE-OPTIC SENSORS (FOS) Optical isotropic fibres made of silica and glass

Unstrained fibres → Unpolarized light remains unpolarized

Strained fibres → Unpolarized light gives polarized signals



Applications as Sensors

- **Damage sensing in bridges and other civil engineering structures**

Uses of Sensors in SHM

A smart sensor is able to convert the physical state of an object or environment such as temperature, light, sound, and/or motion into electrical or other types of signals that may be further processed. A single smart sensor node may have several sensors measuring different physical quantities. Micro-Electro-Mechanical System (MEMS) devices, which are the integration of mechanical elements, sensors, actuators, and electronics on a common silicon substrate through microfabrication technology, are often employed for sensors because of their small size, inexpensive cost (when mass produced), and low power consumption. Data acquisition parameters, such as sampling frequency and data length, can be controlled by the on-board processor. The on-board microprocessor can also access and process the acquired data. The sensing capability provides the interface between the smart sensor's on-board microprocessor and real-world physical phenomena. Wireless communication is possible in sensors. Smart sensors are frequently powered by local batteries, particularly when other power sources are not easily reached. Even when power is available, such as in a building, tethering a large number of smart sensors to power sources is expensive and reduces the merits of wireless communication. Smart sensors primarily composed of MEMS and other integrated circuits (IC) have the potential to be produced at a low cost as well as being small in size. This feature of smart sensors, combined with inexpensive installation cost due to wireless communication, enables numerous smart sensors to be densely distributed over civil infrastructure, thus offering the potential to capture the structure's state in detail, and drawing us closer to realizing the dream of ubiquitous sensing.

Advantages

- Light weight
- Ease in embedding into structures
- Adaptable to diverse geometry
- Non-conductive pathways in structures

Disadvantages

- No actuation capabilities
- Easily damageable & difficult repair